



MANUAL: Flanged Oscillating Monitor

INSTRUCTIONS FOR SAFE OPERATION AND MAINTENANCE

This instruction manual is intended to familiarize firefighters and maintenance personnel with the operation, servicing and safety procedures associated with the Flanged Oscillating Monitor.

This manual should be kept available to all operating and maintenance personnel.

⚠ WARNING

Read instruction manual before use. Operation of this device without understanding the manual and receiving proper training is a misuse of this equipment. A person who has not read and understood all operating and safety instructions is not qualified to operate the Flanged Oscillating Monitor.

⚠ WARNING

Do not attempt to modify the oscillating mechanism to fit any other monitor. To do so will cause the reaction force of the nozzle to be misaligned with the center of rotation. The monitor may spin very fast and could cause injury or death.

⚠ WARNING

Keep hands and fingers away from moving parts of the oscillating unit when water is flowing. There are moving parts that can pinch fingers and hands.

⚠ WARNING

Injury can result from an inadequately supported monitor. The piping structure must be able to withstand the nozzle reaction force which may be as high as 350 lbs (160kg).

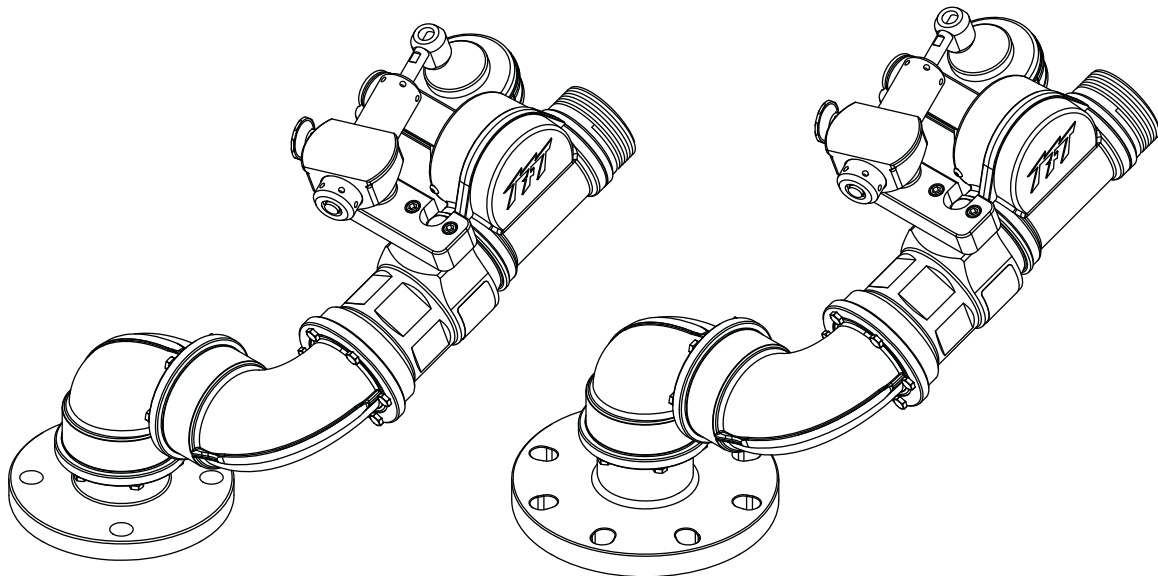

**Maximum Operating Pressure
175 psi (12 bar)**

**Maximum Flow
500 gpm (2000 l/min)**

TASK FORCE TIPS, INC.
MADE IN USA • www.tft.com

3701 Innovation Way, Valparaiso, IN 46383-9327 USA
800-348-2686 • 219-462-6161 • Fax 219-464-7155

TABLE OF CONTENTS

- 1.0 MEANING OF SAFETY WORDS
- 2.0 GENERAL INFORMATION
 - 2.1 OPERATING ENVELOPE
- 3.0 INLETS AND OUTLETS
 - 3.1 OVERALL DIMENSIONS
 - 3.2 STRUCTURAL REQUIREMENTS FOR MONITOR MOUNTING
 - 3.3 TRAVEL LIMITS AND INSTALLATION INSTRUCTIONS
 - 3.4 LOCKING THE MONITOR
 - 3.5 NOZZLE INSTALLATION
- 4.0 USE OF OSCILLATING MECHANISM
 - 4.1 TO ENGAGE THE OSCILLATING MECHANISM
 - 4.2 TO DISENGAGE THE OSCILLATING MECHANISM
- 5.0 COVERAGE AREA OF OSCILLATING MONITOR
- 6.0 MAINTENANCE
- 7.0 FLANGED OSCILLATING MONITOR DRAWING & PARTS LIST
- 8.0 WARRANTY



PERSONAL RESPONSIBILITY CODE

The member companies of FEMSA that provide emergency response equipment and services want responders to know and understand the following:

1. Firefighting and Emergency Response are inherently dangerous activities requiring proper training in their hazards and the use of extreme caution at all times.
2. It is your responsibility to read and understand any user's instructions, including purpose and limitations, provided with any piece of equipment you may be called upon to use.
3. It is your responsibility to know that you have been properly trained in Firefighting and /or Emergency Response and in the use, precautions, and care of any equipment you may be called upon to use.
4. It is your responsibility to be in proper physical condition and to maintain the personal skill level required to operate any equipment you may be called upon to use.
5. It is your responsibility to know that your equipment is in operable condition and has been maintained in accordance with the manufacturer's instructions.
6. Failure to follow these guidelines may result in death, burns or other severe injury.



Fire and Emergency Manufacturers and Service Association
P.O. Box 147, Lynnfield, MA 01940 • www.FEMSA.org

1.0 MEANING OF SAFETY WORDS

A safety related message is identified by a safety alert symbol and a signal word to indicate the level of risk involved with a particular hazard. Per ANSI standard Z535.4-1998 the definitions of the four signal words are as follows:



DANGER indicates an imminently hazardous situation which, if not avoided, will result in death or serious injury.



WARNING indicates a potentially hazardous situation which, if not avoided, could result in death or serious injury.



CAUTION indicates a potentially hazardous situation which, if not avoided, may result in minor or moderate injury.



NOTICE is used to address practices not related to personal injury.

2.0 GENERAL INFORMATION

The Flanged Oscillating Monitor can be used for exposure protection, cooling, or any other situation where it is desirable to have a monitor sweep back and forth. It is intended for mounting on fixed piping structures. The Flanged Oscillating Monitor operates between 20 degrees either side of center, and is adjustable to 90 degrees up and 45 degrees down relative to the flange. The maximum flow rate is 500 gallons per minute.

The oscillating mechanism is driven by a turbine wheel. A worm gear drive reduces the speed and increases the torque of the turbine wheel. A simple crank mechanism makes the outlet of the oscillating monitor and the nozzle attached to it move back and forth. The sweep can be set for a 20, 30, or 40 degree sweep. The oscillating mechanism can be disengaged and the stream can be aimed manually. The speed of the oscillator is a function of the flow rate.

2.1 OPERATING ENVELOPE

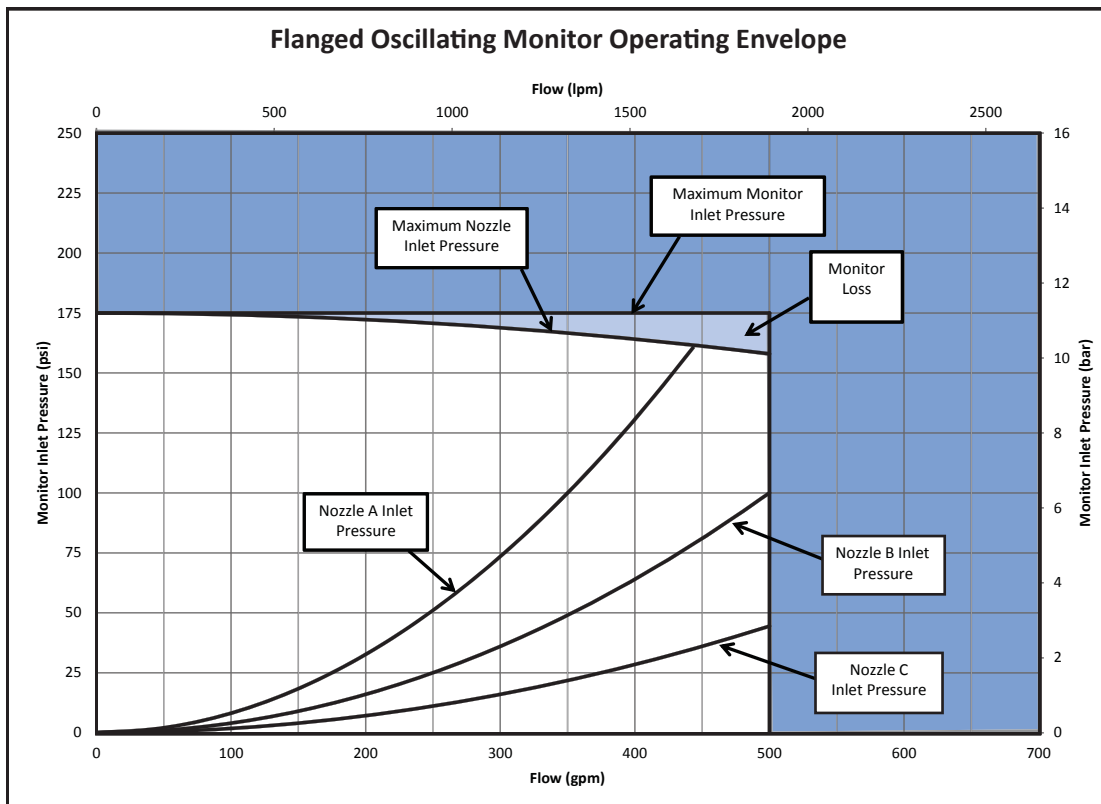

Nozzle A flows 350 gpm (1300l/m) at 100 psi (7 bar), K factor = 35
 Nozzle B flows 500 gpm (1900 l/min) at 100 psi (7 bar), K factor = 50
 Nozzle C flows 750 gpm (2900 l/min) at 100 psi (7 bar), K factor = 75

3.0 INLETS AND OUTLETS

The standard Flanged Oscillating Monitor inlet is a 3" ANSI 150 flange. Monitor inlet with oblong bolt holes for 4" ANSI 150/DN100 PN 16 is also available. The standard outlet is a 2.5"-7.5 National Hose male. Various other inlet and outlet adapters are shown below.

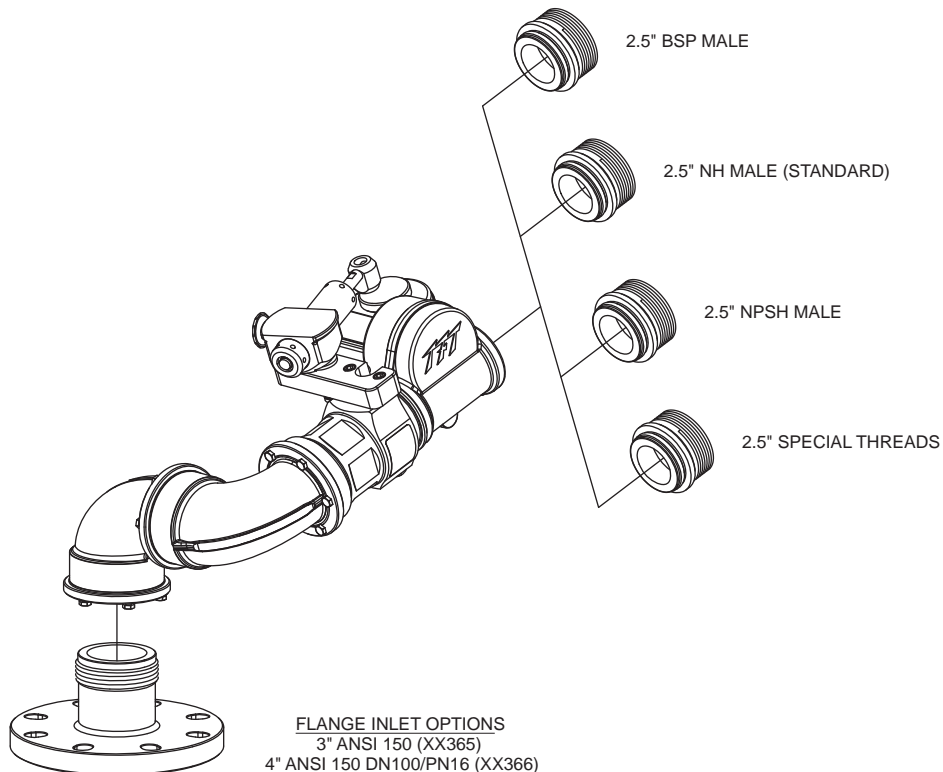

3.1 OVERALL DIMENSIONS

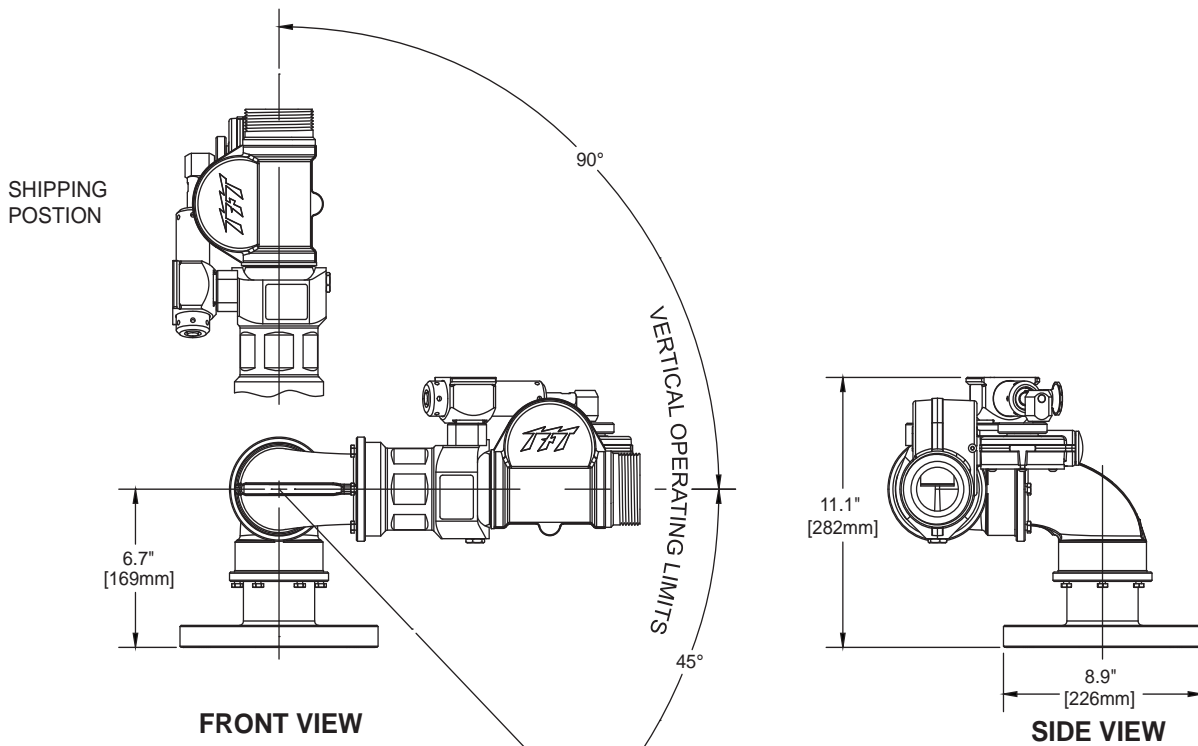
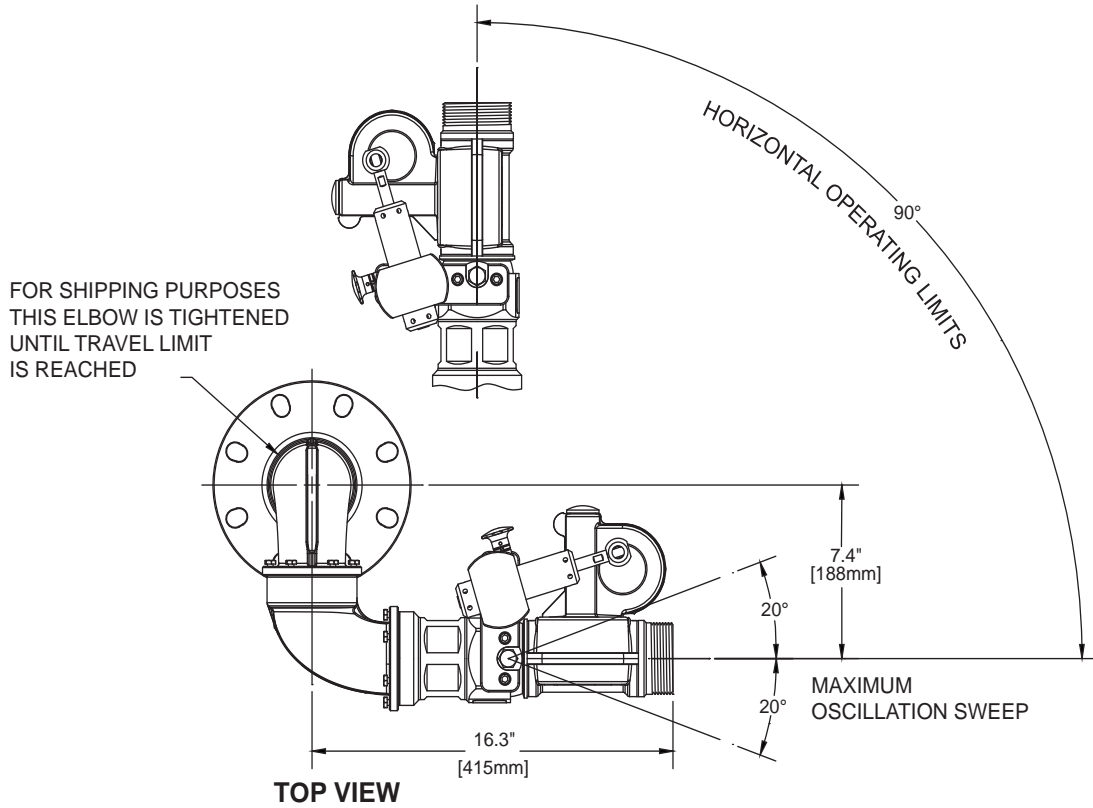

**FLANGE INLET OPTION
4" ANSI 150/DN100 PN16**

FOR SHIPPING PURPOSES
THIS ELBOW IS TIGHTENED
UNTIL TRAVEL LIMIT
IS REACHED

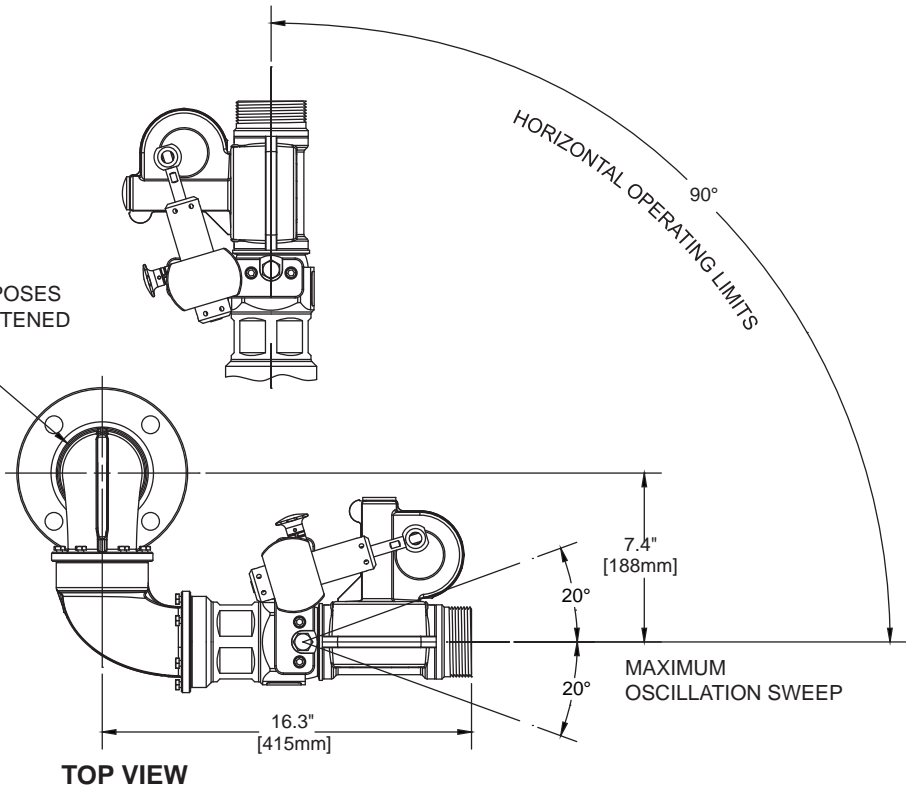

TOP VIEW

SHIPPING
POSITION

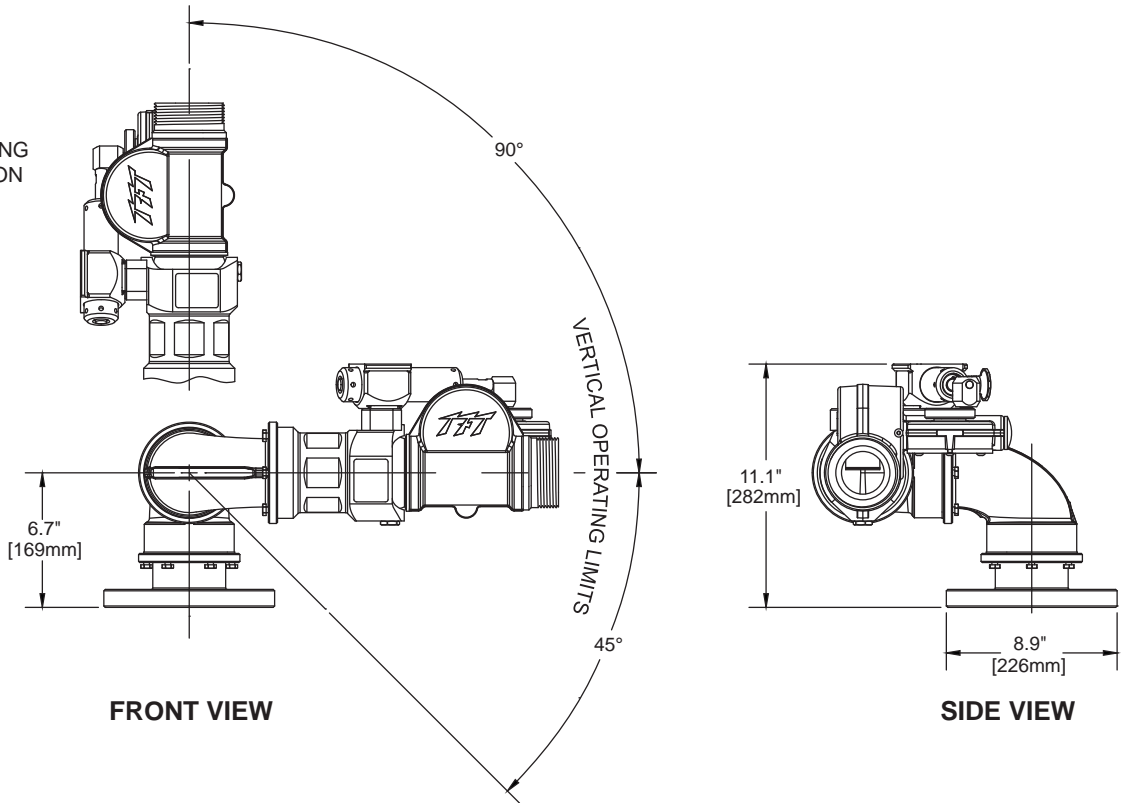

FRONT VIEW

SIDE VIEW

**FLANGE INLET OPTION
3" ANSI 150**

3.2 STRUCTURAL REQUIREMENTS FOR MONITOR MOUNTING

The structure that the Fixed Oscillating Monitor is mounted to must withstand the internal pressure of the monitor as well as shear and bending forces due to nozzle reaction. Nozzle reaction can be as high as 350 lbs (160 kg) (500 gpm at 175 psi). For flanged connections the use of flat flanges without raised faces is recommended. Use a ring gasket as defined in ASME 16.21 or ISO 7483. Tighten flange bolts in an alternating sequence as shown in figure 6.1. Tighten to 76-80 ft-lb (100-110 Newton-Meters).

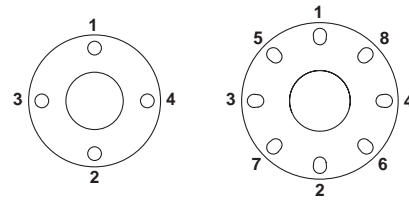

TIGHTEN SEQUENTIALLY EACH BOLT THREE TIMES
FLANGE BOLT TIGHTENING SEQUENCE

3.3 TRAVEL LIMITS AND INSTALLATION INSTRUCTIONS

The range of elevation travel for the Flanged Oscillating Monitor is 90 degree above and 45 degrees below relative to the flange. The range of horizontal travel for the Flanged Oscillating Monitor is 90 degrees. The maximum sweep angle for the Flanged Oscillating Monitor is 20 degrees of center. To set the monitor position, point the monitor at the desired target. Then, rotate the flange until the bolt holes are aligned. Do not rotate the monitor more than 90 degrees when aligning the holes. Doing so will cause loss of sealing. Once the holes are aligned, tighten the flange bolts per Section 3.2, and then tighten the monitor ring bolts per section 3.4

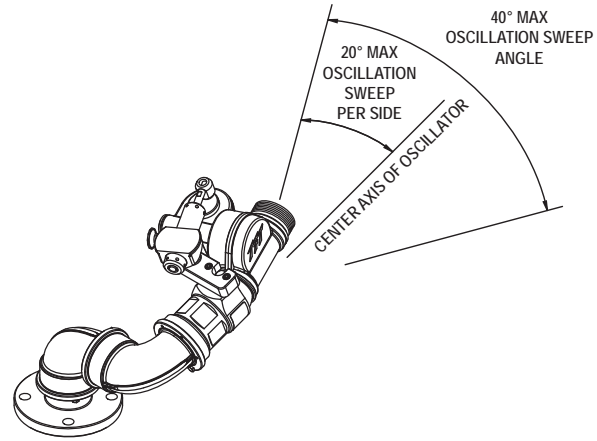
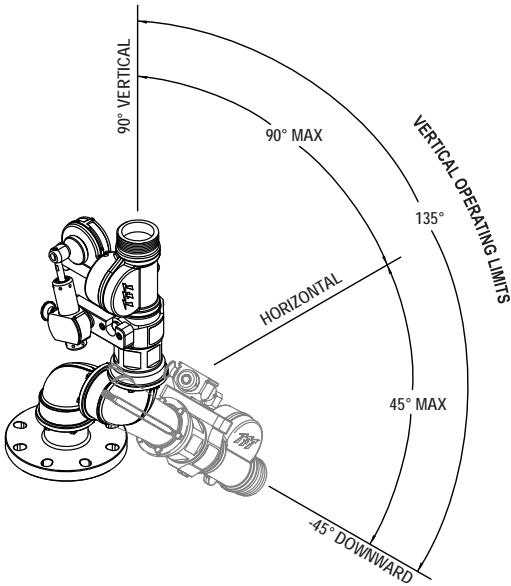

WARNING

Do not adjust the monitor swivels to operate beyond the travel limits shown in step 3 of the figure below. Adjusting the monitor swivels beyond their intended range of travel can disable the locking screws, causing a sudden change in monitor direction and resulting in injury from an out of control stream. The monitor is shipped from the factory at the highest travel limit. Do not loosen the monitor past this point.

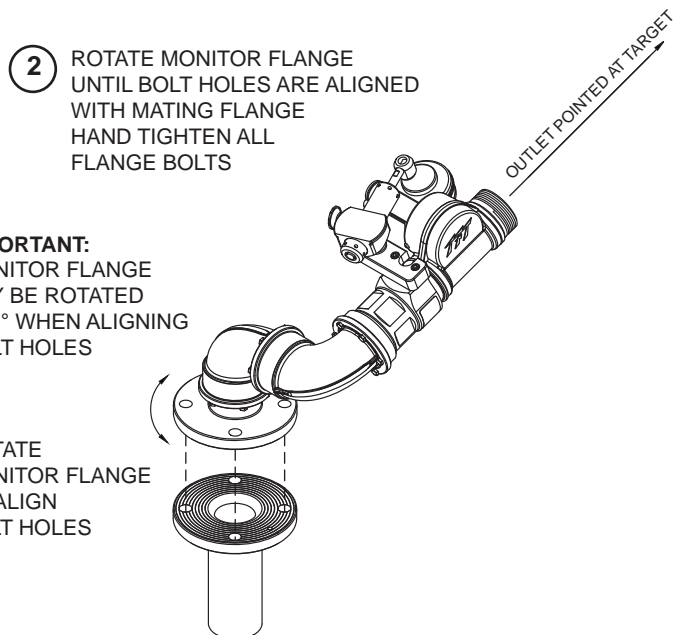
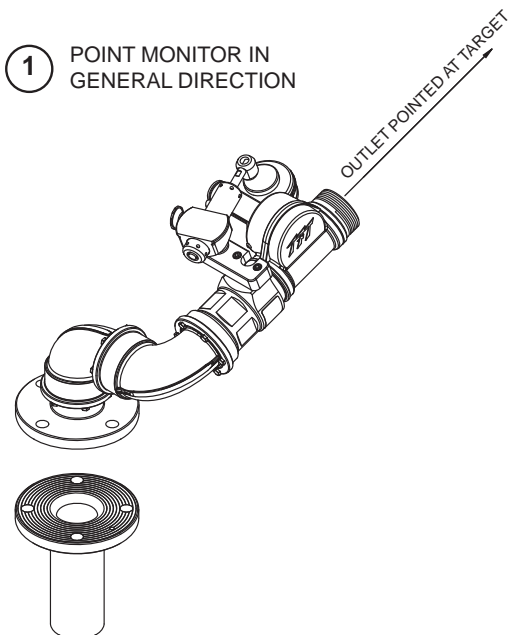

3

LOOSEN ELEVATION ELBOW RING BOLTS. TIGHTEN ELEVATION ELBOW FULLY AND THEN LOOSEN TO AIM.

IMPORTANT:
NEVER LOOSEN ELEVATION ELBOW PAST VERTICAL RELATIVE TO FLANGE

ELEVATION ELBOW RING BOLTS

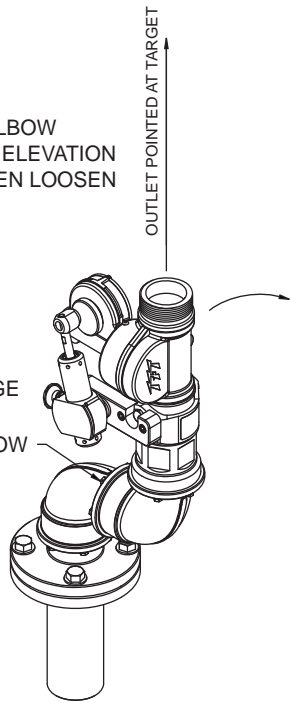

4

LOCK DOWN RING BOLTS PER SECTION 3.4

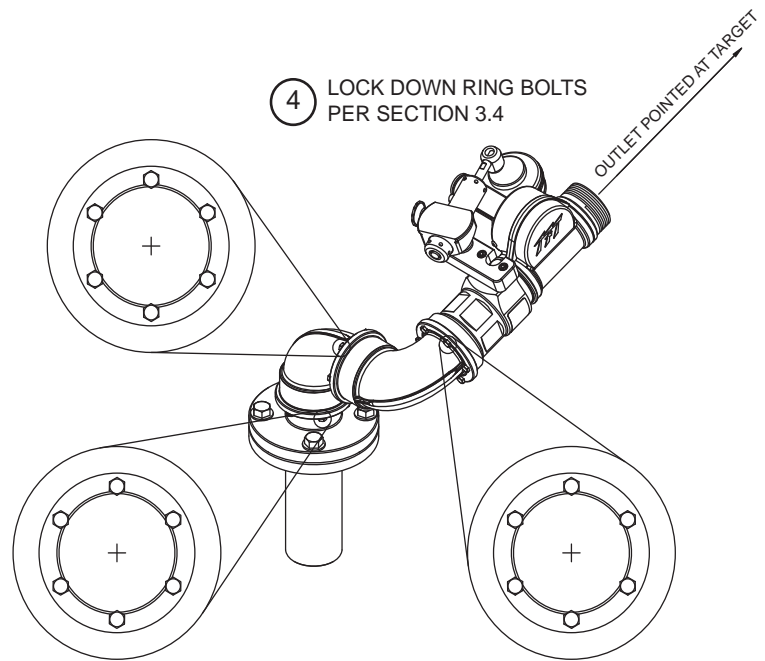

5

TORQUE FLANGE BOLTS PER SECTION SECTION 3.2

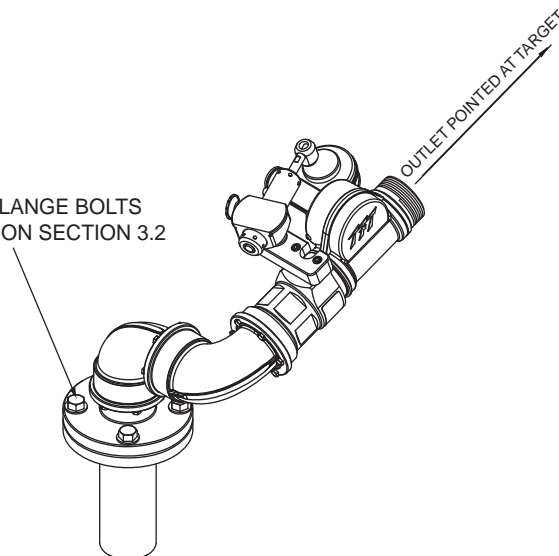

3.4 LOCKING THE MONITOR

The Flanged Oscillating Monitor is to be locked in place before it is operated. To lock the device, rotate the elbows so the nozzle is pointed at the desired target. Snug up the ring bolts finger tight until they are all in contact. Then, tighten the hex bolts 1/2 turn using a 7/16" (11mm) wrench. Tighten bolts in the alternating pattern shown. Do not tighten the ring bolts past 1/2 turn.

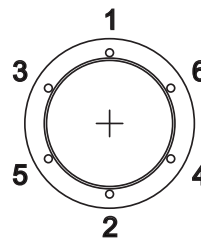

WARNING

Do not operate the Flanged Oscillating Monitor until the locking bolts have been secured. Operation with unsecured bolts can cause a sudden change of monitor position, resulting in injury from an out of control stream. The Flanged Oscillating Monitor is shipped from the factory with the bolts unsecured and ready for installation. Tighten bolts before using the monitor.

3.5 NOZZLE INSTALLATION

The nozzle is simply screwed onto the monitor's exit threads.

CAUTION

The nozzle threads must match the outlet threads of the Flanged Oscillating Monitor in both size and type. Mismatched or damaged threads may cause the nozzle to leak or uncouple under pressure and could cause injury.

CAUTION

Do not connect aluminum to brass or brass to aluminum. Dissimilar metals coupled together can cause galvanic corrosion that will freeze the threaded joint or cause complete loss of thread engagement. If dissimilar metals must be coupled together, the effects of corrosion can be greatly delayed by various coatings on the metal such as powder paint, hard anodizing, or silicone grease.

4.0 USE OF OSCILLATING MONITOR

4.1 TO ENGAGE THE OSCILLATING MECHANISM

If the nozzle moves freely left to right by hand, the oscillating mechanism is not engaged. To engage, ensure the black knob on the side of the oscillator is released, and move the nozzle from one side to the other until the black knob clicks into the groove on the spring canister. The minimum flow required to oscillate is 175 gpm (650 l/min).

The oscillating mechanism is equipped with a safety device that prevents damage to the gear train in case the oscillator comes in contact with an object. The safety device will allow the mechanism to continue to oscillate the portion of its sweep path not blocked by the obstruction. The safety mechanism also allows the oscillating mechanism to sweep vertically without disengaging the oscillator.

Once obstruction is removed, sweep pattern will return to normal.

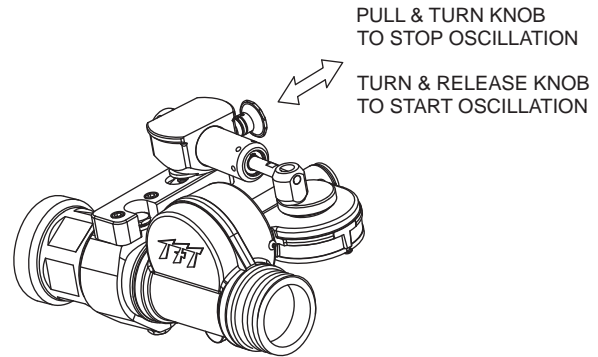

OSCILLATION CONTROL

CAUTION

The ends of the covered area will receive more water than the center because the oscillator must slow down, stop, and reverse direction at the end of each sweep. If the center area of coverage needs more cooling, it may be necessary to occasionally narrow the area of coverage or direct the stream manually.

4.2 TO DISENGAGE THE OSCILLATING MECHANISM

To operate the oscillating monitor manually, pull then twist the black knob located on the side of the monitor. Twisting will lock the knob in the disengaged position. The crank, rod, and spring canister will continue to move. Move the nozzle to the desired position by hand.

5.0 COVERAGE AREA OF OSCILLATING MONITOR

To adjust the area of coverage, refer to figure 5.0. Engage the oscillating mechanism once the desired angle has been set.

Oscillation speed: The chart shows how many times per minute the oscillator makes one complete cycle as a function of flow. The higher the flow, the faster it oscillates.

For nozzle reach, refer to the operating manual for the specific nozzle. For reach with oscillation, subtract 20% from the distance

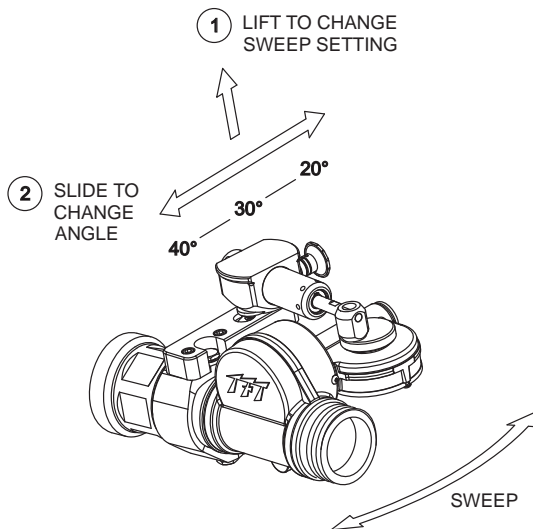
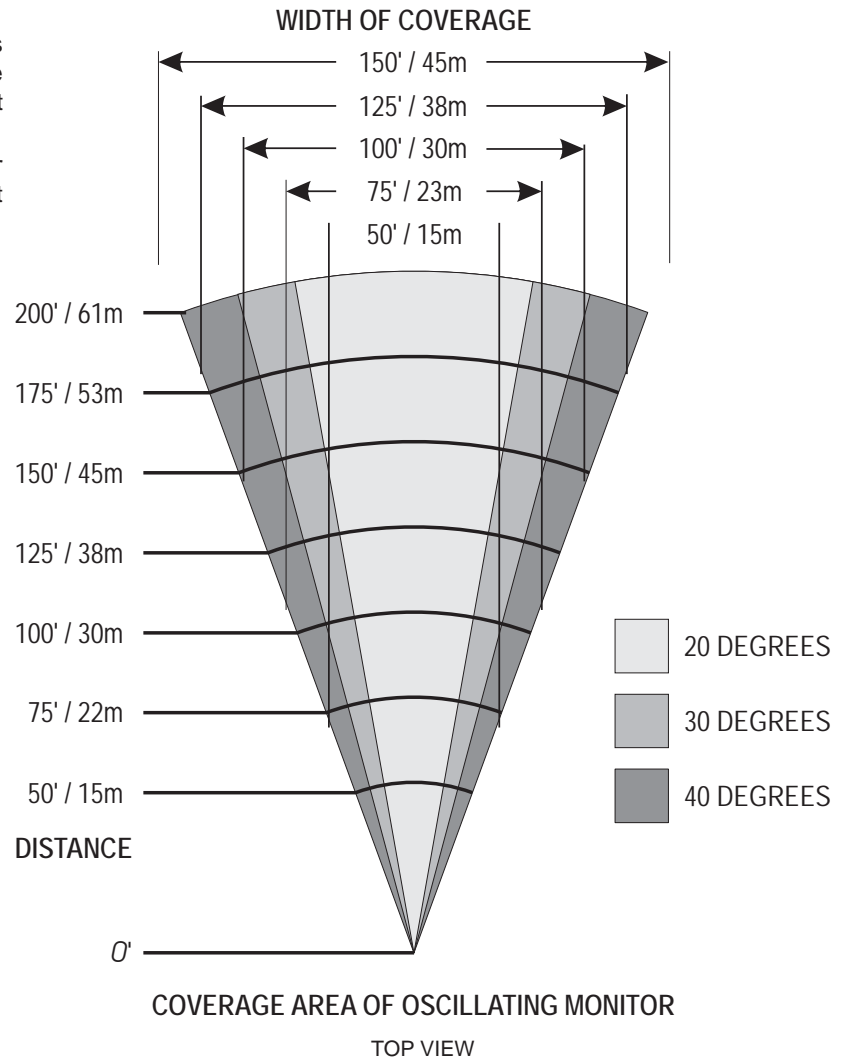

Fig. 5.0 Adjusting Sweep Angle

APPROXIMATE CYCLES/MIN	GPM	L/MIN
8	175	650
13	250	1000
21	375	1500
28	500	2000

OSCILLATION SPEED



COVERAGE AREA OF OSCILLATING MONITOR

TOP VIEW

NOTICE

The type of nozzle and flow pressure are critical to the coverage area. The graph shows coverage area based on the movement capability of the oscillating mechanism. Actual coverage will depend on flow, pressure, type of nozzle, angle of fog pattern and wind conditions.

6.0 MAINTENANCE

The flanged oscillating monitor is intended for intermittent use with fresh water in fire protection and extinguishment applications. All parts are permanently lubricated and should not require maintenance beyond normal inspections. The waterway should be drained between uses.

WARNING

The monitor may be damaged if frozen while containing sufficient amounts of water. The monitor should be installed in an orientation that does not allow standing water to remain or collect inside the monitor between uses. Installation of drain valves may be necessary in some cases. Such damage may be difficult to detect visually and can lead to possible injury or death. Any time the monitor is subject to possible damage from freezing, it must be hydrostatically tested by qualified personnel before being considered safe for use.

CAUTION

Use with salt water is permissible provided monitor is thoroughly cleaned with fresh water after each use. The service life of the monitor may be shortened due to the effects of corrosion and is not covered under warranty.

7.0 FLANGED OSCILLATING MONITOR DRAWING & PARTS LIST

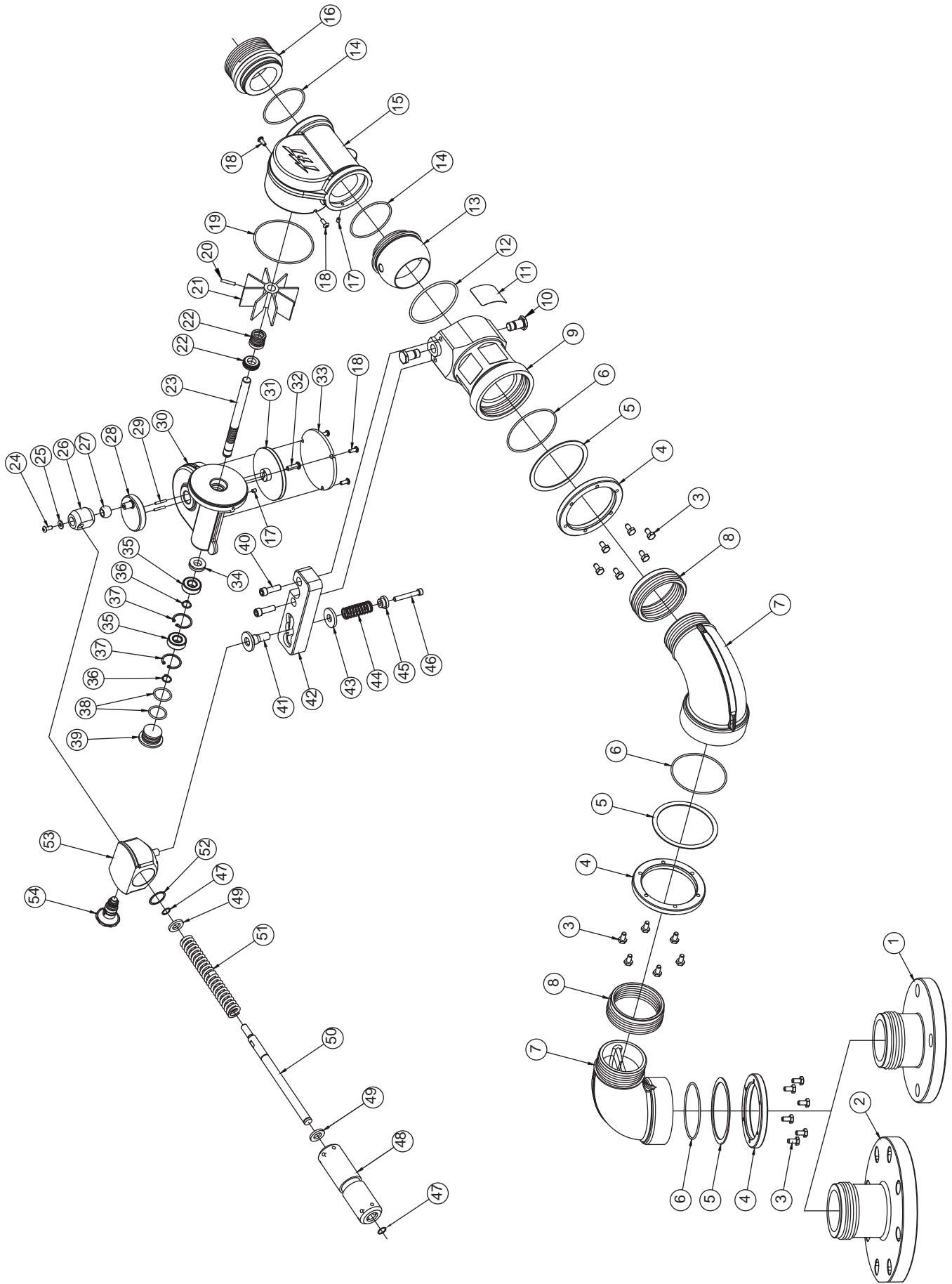

ITEM	DESCRIPTION	QTY.	PART #
1	3" ANSI 150	1	XX365
2	4" ANSI 150		XX366
3	1/4-20 X 1/2 HEX HEAD BOLT	18	VT25-20HX500
4	LOCKING RING	3	XX360
5	SPACER RING	3	XX369
6	O-RING-152	3	VO-152
7	ELBOW ALUM 2.5"BSP	2	X339FL
8	ADAPTER RING	2	XX361
9	OSCILLATOR INLET 3"BSP	1	XX308FL
10	SWIVEL TRUNNION	2	XX320
11	FLANGED OSCILLATING MONITOR NAME LABEL	1	XX373
12	O-RING-235	1	VO-235
13	INLET BALL	1	XX015
14	O-RING-147	2	VO-147
15	WATERWAY AMERICAN RED	1	XX010-ARED
16	EXIT OSC. 2.5"	1	XX020*
17	10-32 X 1/4 SET SCREW	3	VT10-32SS250
18	10-32 X 1/2 BUTTON HEAD SCREW	5	VT10E32BH500
19	O-RING-153	1	VO-153
20	5/32 X 7/8 HDP SPIROL PIN	1	V1900
21	TURBINE VANES	1	XX025
22	TURBINE SEAL	1	XX032
23	WORM AND SHAFT	1	XX030
24	10-32 X 1/2 BHCS - NYLOK PATCH	1	VT10Y32BH500
25	WASHER	1	VW500X203-60
26	OFFSET ROD END	1	XX057
27	SPHERICAL BUSHING	1	XX058

ITEM	DESCRIPTION	QTY.	PART #
28	CRANK	1	XX362
29	DOWEL PIN	2	VP125X.75
30	GEAR BOX AMERICAN RED	1	XX005-ARED
31	WORM GEAR	1	XX040
32	1/4-20 X 7/8 SOCKET HEAD SCREW	1	VT25-20SH875
33	COVER	1	XX045
34	CUP SEAL	1	XX033
35	WORM SHAFT BEARING	2	XX035
36	SNAP RING 1/2" EXTERNAL	2	VR4250
37	SNAP RING 1-1/8" INTERNAL	2	VR4255
38	O-RING-119	2	VO-119
39	SHAFT CAP	1	XX037
40	5/16-18 X 1 SOCKET HEAD SCREW	2	VT31-18SH1.0
41	DETENT BUSHING	1	XX376
42	ARM	1	XX061
43	WASHER	1	XX377
44	SPRING	1	C031
45	SPRING RETAINER	1	XX378
46	1/4-20 X 1.75 SOCKET HEAD SCREW	1	VT25-20SH1.7
47	SMALLEY RING	2	VR4280
48	SPRING TUBE	1	XX367
49	WASHER	2	XX364
50	LINK	1	XX363
51	SPRING	1	XX371
52	SMALLEY RING	1	VR4340
53	SLIDER BLOCK	1	XX368
54	LATCHING PULL PIN SUBASSEMBLY	1	XX935
	* Consult Factory for special threads		

8.0 WARRANTY

Task Force Tips, Inc., 3701 Innovation Way, Valparaiso, Indiana 46383-9327 ("TFT") warrants to the original purchaser of its Oscillating Fixed Monitor ("equipment"), and to anyone to whom it is transferred, that the equipment shall be free from defects in material and workmanship during the five (5) year period from the date of purchase.

TFT's obligation under this warranty is specifically limited to replacing or repairing the equipment (or its parts) which are shown by TFT's examination to be in a defective condition attributable to TFT. To qualify for this limited warranty, the claimant must return the equipment to TFT, at 3701 Innovation Way, Valparaiso, Indiana 46383-9327, within a reasonable time after discovery of the defect. TFT will examine the equipment. If TFT determines that there is a defect attributable to it, it will correct the problem within a reasonable time. If the equipment is covered by this limited warranty, TFT will assume the expenses of repair.

If any defect attributable to TFT under this limited warranty cannot be reasonably cured by repair or replacement, TFT may elect to refund the purchase price of the equipment, less reasonable depreciation, in complete discharge of its obligations under this limited warranty. If TFT makes this election, claimant shall return the equipment to TFT free and clear of any liens and encumbrances.

This is a limited warranty. The original purchaser of the equipment, any person to whom it is transferred, and any person who is an intended or unintended beneficiary of the equipment, shall not be entitled to recover from TFT any consequential or incidental damages for injury to person and/or property resulting from any defective equipment manufactured or assembled by TFT. It is agreed and understood that the price stated for the equipment is in part consideration for limiting TFT's liability. Some states do not allow the exclusion or limitation of incidental or consequential damages, so the above may not apply to you.

TFT shall have no obligation under this limited warranty if the equipment is, or has been, misused or neglected (including failure to provide reasonable maintenance) or if there have been accidents to the equipment or if it has been repaired or altered by someone else.

THIS IS A LIMITED EXPRESS WARRANTY ONLY. TFT EXPRESSLY DISCLAIMS WITH RESPECT TO THE EQUIPMENT ALL IMPLIED WARRANTIES OF MERCHANTABILITY AND ALL IMPLIED WARRANTIES OF FITNESS FOR A PARTICULAR PURPOSE. THERE IS NO WARRANTY OF ANY NATURE MADE BY TFT BEYOND THAT STATED IN THE DOCUMENT.

This limited warranty gives you specific legal rights, and you may also have other rights which vary from state to state.