



MANUAL: BLITZFIRE Portable Monitor Series

INSTRUCTIONS FOR SAFE OPERATION AND MAINTENANCE

⚠ DANGER

Read Instruction Manual before use. Operation of this monitor without understanding the manual and receiving proper training can be dangerous and is a misuse of this equipment. Call 800-348-2686 with any questions.

⚠ DANGER

Risk of sliding increases at low elevation angles. To reduce risk of injury or death from sliding, test safety elevation plunger before using.

NOTICE

This Instruction Manual is intended to familiarize firefighters and maintenance personnel with the operation, servicing, and safety procedures associated with the portable monitor.

NOTICE

This manual should be kept available to all operating and maintenance personnel.

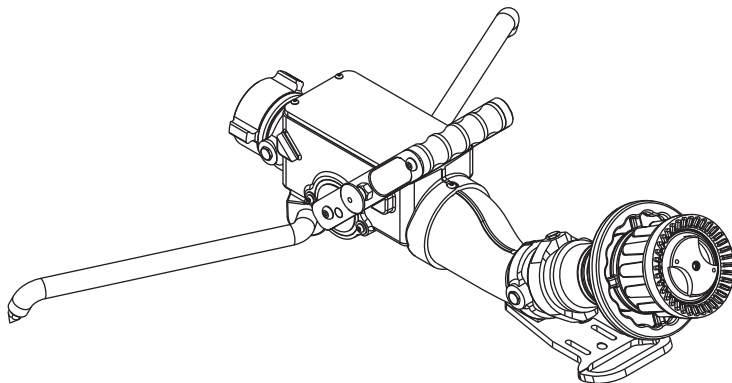

BLITZFIRE®

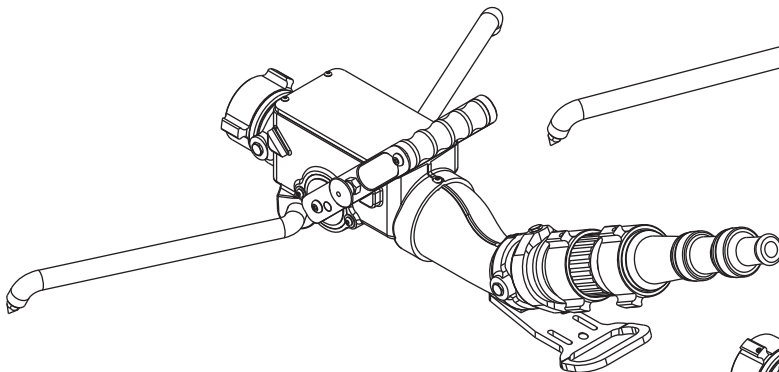

MAXIMUM OPERATING PRESSURE
175 PSI (12 BAR)

MAXIMUM FLOW
500 GPM (2000 LPM)

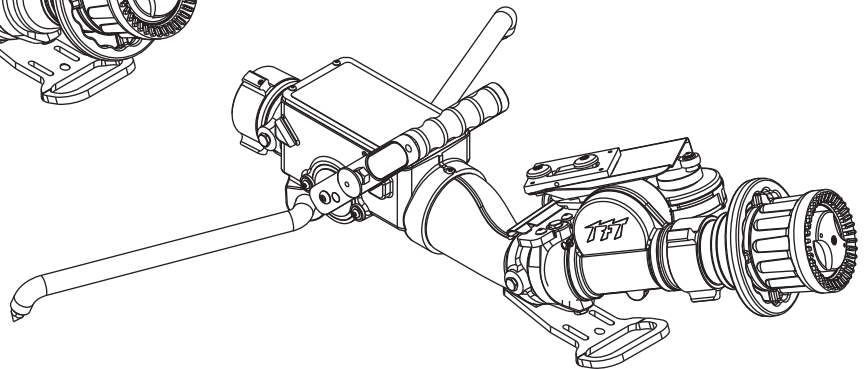

BLITZFIRE OSC®

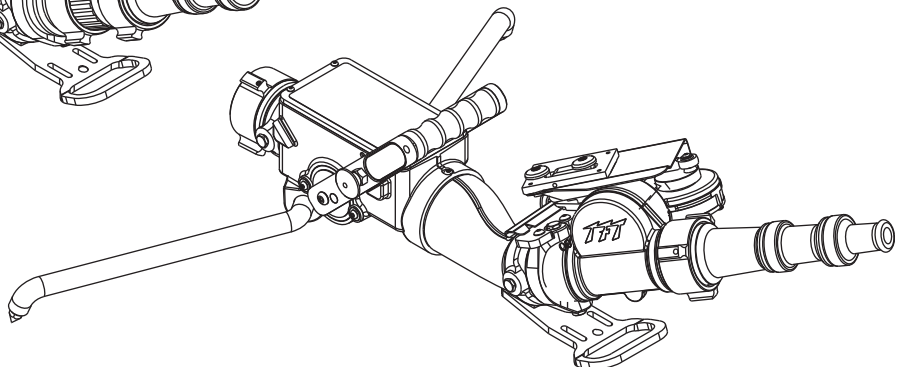

TASK FORCE TIPS, INC.
MADE IN USA • www.tft.com

3701 Innovation Way, Valparaiso, IN 46383-9327 USA
800-348-2686 • 219-462-6161 • Fax 219-464-7155

Table Of Contents

| | |
|---|---|
| 1.0 Meaning of Signal Words | 5.0 Anchoring |
| 2.0 General Information | 5.1 Anchoring by Weight |
| 2.1 Blitzfire Part Identification | 5.2 Anchoring by Spike Holds |
| 2.2 Flow Control Valve | 5.3 Anchoring by Hooking Legs |
| 2.2.1 Unlocking the Valve Handle from the Closed Position | 5.4 Anchoring by Tying Off |
| 2.2.2 Safety Shut-Off Valve Operation | 6.0 OSC Oscillating Unit |
| 2.2.3 Safety Shut-Off Valve Test | 6.1 Safety - Oscillator |
| 2.2.4 Manual Override of Safety Shut-Off Valve | 6.2 General - Oscillator |
| 2.2.5 Slow Close Valve Feature | 6.3 Control Identification - Oscillator |
| 2.3 Folding Legs | 6.4 Use - Oscillator |
| 2.3.1 Carbide Spikes | 7.0 Storage |
| 2.4 Pivoting Inlet | 8.0 Maintenance |
| 2.5 Outlet Pivots | 9.0 Warranty |
| 2.5.1 Elevation Holding Mechanism | 10.0 Exploded View and Parts List |
| 3.0 Flows and Pressures | 10.1 Safety Mechanism |
| 3.1 Automatic, Fixed, and Selectable Flow Nozzles | 10.2 Blitzfire Monitor |
| 3.2 Stacked Tips or Smoothbore Nozzles | 10.3 Oscillator |
| 3.3 Stream Straighteners | 11.0 Operation Checklist |
| 3.4 Use with Foam | |
| 3.5 Use with Salt Water | |
| 3.6 Blitzfire Pressure Loss | |
| 3.7 Oscillating Blitzfire Pressure Loss | |
| 4.0 Deployment of Blitzfire | |
| 4.1 Carrying with an Uncharged Hose | |
| 4.2 Advancing with a Charged Hose | |



PERSONAL RESPONSIBILITY CODE

The member companies of FEMSA that provide emergency response equipment and services want responders to know and understand the following:

1. Firefighting and Emergency Response are inherently dangerous activities requiring proper training in their hazards and the use of extreme caution at all times.
2. It is your responsibility to read and understand any user's instructions, including purpose and limitations, provided with any piece of equipment you may be called upon to use.
3. It is your responsibility to know that you have been properly trained in Firefighting and /or Emergency Response and in the use, precautions, and care of any equipment you may be called upon to use.
4. It is your responsibility to be in proper physical condition and to maintain the personal skill level required to operate any equipment you may be called upon to use.
5. It is your responsibility to know that your equipment is in operable condition and has been maintained in accordance with the manufacturer's instructions.
6. Failure to follow these guidelines may result in death, burns or other severe injury.



Fire and Emergency Manufacturers and Service Association
P.O. Box 147, Lynnfield, MA 01940 • www.FEMSA.org

1.0 MEANING OF SAFETY SIGNAL WORDS

A safety related message is identified by a safety alert symbol and a signal word to indicate the level of risk involved with a particular hazard. Per ANSI standard Z535.6-2006, the definitions of the four signal words are as follows:



DANGER indicates a hazardous situation which, if not avoided, will result in death or serious injury.



WARNING indicates a hazardous situation which, if not avoided, could result in death or serious injury.



CAUTION indicates a potentially hazardous situation which, if not avoided, may result in minor or moderate injury.



NOTICE is used to address practices not related to personal injury.

2.0 SAFETY

The Blitzfire is a simple, light and easy to maneuver portable monitor. The monitor has a revolutionary safety shut-off valve, which will shut-off the water flow in the event of sudden movement by the monitor. This safety feature reduces the risk of injury from an out of control master stream device. General product specifications are as follows:

- Standard Inlet Coupling: 2 ½ inch NH Female
- Standard Outlet: 2 ½ inch NH male
- Flow range: up to 500 GPM (2000 LPM)
- Maximum inlet pressure: 175 PSI (12 BAR)
- Vertical Stream Range: 10 to 50 degrees above horizontal
- Horizontal Stream Range: +/- 20 degrees either side of centerline
- Size, legs folded: 25.5"Lx8.1"Wx10"H(650x210x260mm)
- Size, legs unfolded: 26"Lx34"Wx10" H(660x1020x260mm)
- Weight: 22 lbs (10 kg)

⚠ WARNING

This equipment is intended for use by trained personnel for firefighting. Its use for other purposes may involve hazards not addressed by this manual. Seek appropriate guidance and training to reduce risk of injury.

⚠ WARNING

An out of control monitor can cause injury or death. To reduce the risk of instability, do not attempt to move the monitor with water flowing.

⚠ WARNING

Interrupting flow to the monitor may cause injury or death. Avoid situations that may interrupt flow to the monitor such as: hose line kinks, traffic running over hose, and automatic doors or devices that can pinch the hose.

⚠ CAUTION

Master streams are powerful and capable of causing injury and property damage. Make sure the monitor is pointing in a safe direction before water to the nozzle is turned on. Use care in directing the stream.

⚠ CAUTION

Monitor must be properly connected to hose and nozzle. Mismatched or damaged threads may cause leaking or uncoupling under pressure and could cause injury.

⚠ CAUTION

Do not couple aluminum to brass. Dissimilar metal coupled together can cause galvanic corrosion that can result in inability to unscrew threads or complete loss of thread engagement over time.

2.1 BLITZFIRE PART IDENTIFICATION

Figure 2.1 identifies the various parts and controls of the Blitzfire Portable Monitor.

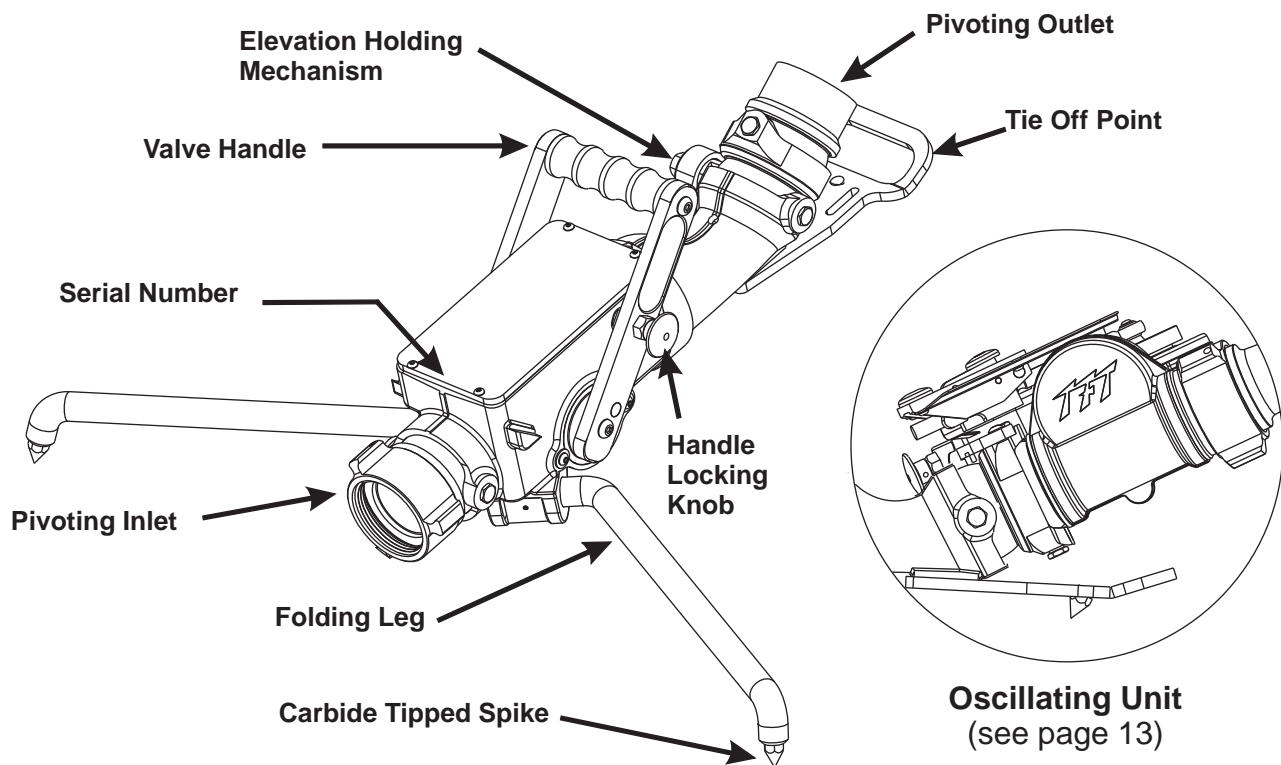

Figure 2.1 Blitzfire Parts and Controls

2.2 FLOW CONTROL VALVE

The Blitzfire has a valve that can be used to control the flow and acts as a safety shut-off feature. The valve is shut-off when the valve handle is fully forward. The valve is fully on when the valve handle is fully back. The valve can be opened to any of six detented flow positions. These detented positions allow the monitor operator to regulate the flow depending on the need or what can be safely and effectively handled. Figure 2.2 illustrates the positions of the valve handle.

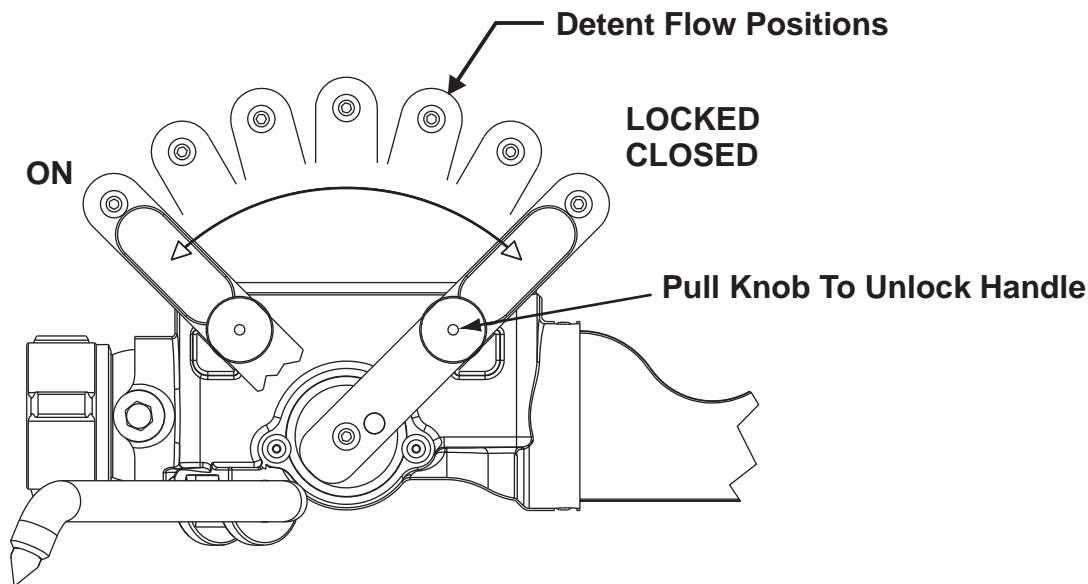

Figure 2.2 Valve Handle Positions

2.2.1 UNLOCKING THE VALVE HANDLE FROM THE CLOSED POSITION

The valve handle is locked in the closed position so that the valve handle may be used to carry the Blitzfire without the valve inadvertently opening. To unlock the valve handle from the closed position:

1. Pull knob on right side of valve handle.
2. While pulling on knob, open the valve with other hand.

As soon as valve is opened the knob may be released. Valve handle may be moved to any detent valve position by pushing or pulling on the valve handle. When the valve is closed the valve handle automatically locks and must be unlocked again to reopen. The valve opening procedure is shown in figure 2.2.1.

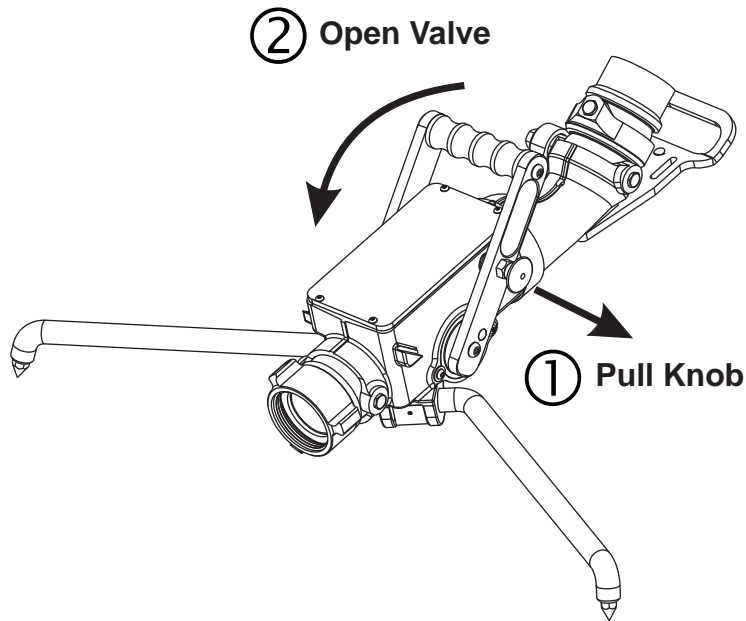
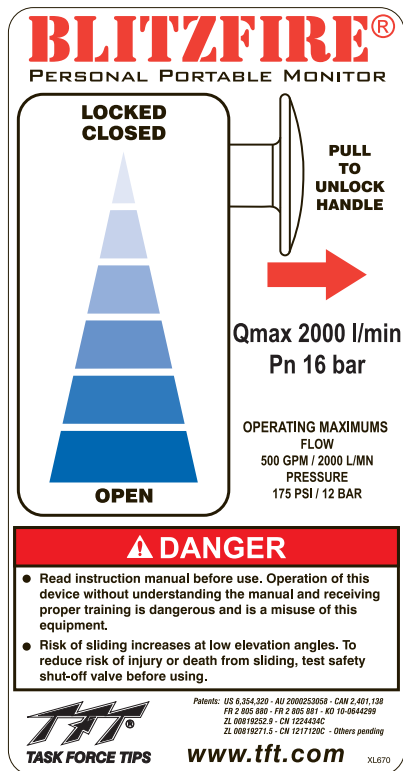

Figure 2.2.1 Valve Opening Procedure

2.2.2 SAFETY SHUT-OFF VALVE OPERATION

The Blitzfire is equipped with a Safety Shut-Off Valve. The Safety Shut-Off Valve will shut off the monitor's flow if the monitor starts to move. The Safety Shut-Off Valve relies on acceleration of the Blitzfire as the signal to activate. It activates at approximately one G of sideways acceleration. Placing the Blitzfire on tilted surfaces (greater than 10 degrees) may inhibit the resetting of the Safety Shut-Off Valve. The hose connected to the Blitzfire should contain any forward or backwards motion to safe levels.

NOTE: To make the Blitzfire not shut off completely, see the card titled "Instructions to Maintain Minimal Water Flow When the Safety Shut-off Activates". (LIX-640)

Safety shut-off valve operation:

1. Set up monitor and charge the hose.
2. Point the nozzle in the desired direction.
3. Open the valve by pulling the locking pin and pulling back on the valve handle (see section 2.2.1)
4. Place the valve handle in the desired detent position (further back for more flow, further forward for less).
5. If the monitor starts to slide, the safety valve will sense the movement and release the valve.
 - An internal spring and water pressure will move the valve forward to the closed position and shut off the water flow.
 - The valve handle will lock in the closed position.
6. The safety shut-off valve will automatically reset.
7. After the cause of the sliding has been corrected, reopen the valve as outlined in step 3.

IMPORTANT: Valve must be fully closed to reset the safety shut-off mechanism. Once tripped the valve handle will not stay open unless the mechanism is reset by fully closing the valve.

If the safety shut-off valve fails to reset, the valve will not remain open. Failure to reset may be due to placing the monitor on an excessively sloped surface.

⚠ WARNING

The safety shut-off valve is only sensitive to sideways acceleration of the monitor. Keep the hose directly behind the monitor to reduce potential acceleration in the forward and backward direction. Do not loop hose in front of monitor.

⚠ WARNING

The safety shut-off valve needs approximately one G of sideways acceleration to activate. At low accelerations the monitor may travel several yards (meters) and gain enough velocity to cause injury before the safety shut-off valve activates. Personnel several feet away and in the potential path of a sliding monitor are at risk of injury. Keep non operating personnel out of the potential path of a sliding monitor.

⚠ WARNING

Improper repairs may result in a malfunctioning safety shut-off valve. If repair is needed on the safety shut-off valve, return the monitor to Task Force Tips.

2.2.3 SAFETY SHUT-OFF VALVE TEST

⚠ WARNING

To avoid injury or death, test safety shut-off valve before each use.

With hose uncharged and Blitzfire on a level surface:

1. Open the Valve Handle to the fully open position.
2. Grasp the monitor and give it a sideways jerk, rotate to trip the valve or hit on the side with a rubber mallet.
3. The Valve Handle should move to the closed position.

Note: With water flowing the valve has additional forces on it that will close the valve the rest of the way.

If the Safety Shut-Off Valve fails the test, return the monitor to Task Force Tips to restore proper functioning of the safety shut-off valve. If the monitor is used before repair, the user accepts the risk of an out of control monitor.

⚠ WARNING

The safety shut-off valve is intended to shut off the monitor when it moves. It will not prevent it from moving. The device will limit the motion and injury that may occur once the monitor starts to move. Use adequate means to secure the monitor to prevent injury.

⚠ WARNING

Injury or death from an out of control monitor can occur. If monitor gets out of control retreat from monitor immediately. Do not attempt to regain control of monitor while it is flowing.

2.2.4 MANUAL OVERRIDE OF SAFETY SHUT-OFF VALVE

On sloping terrain it may be necessary to manually override the Safety Shut-Off Valve. The Safety Shut-Off Valve can be overridden by holding the valve handle in an open position.

⚠ WARNING

Do not tie or prop open the valve handle. Tampering with the valve handle will render the Safety Shut-Off inoperable and may result in injury or death.

2.2.5 SLOW CLOSE VALVE FEATURE

The Blitzfire has a valve damping mechanism to slow valve closure as it approaches OFF to reduce the effects of water hammer. The damping mechanism has a vane moving in dampening fluid connected to the valve handle on the left side of the monitor.

⚠ WARNING

Do not add or change dampening fluid. Improper servicing may result in a malfunctioning safety shut-off valve. If service is needed on the slow close device, contact Task Force Tips service department at 800-348-2686.

2.3 FOLDING LEGS

The Blitzfire has two legs that fold for storage and unfold for operation. The legs are held in the folded and unfolded position by spring detents. To fold or unfold the legs:

1. Grasp the spike end of one leg and pivot it to the folded or unfolded position.
2. Repeat for the other leg.

⚠ WARNING

In the unfolded position the legs provide a stable base for operation of the monitor. Lack of stability can cause an out of control monitor resulting in injury or death. Do not operate as a portable monitor with either one or both legs in the folded position.

2.3.1 CARBIDE SPIKES

The Blitzfire monitor has 3 tungsten carbide tipped spikes on the legs and the base to resist sliding by digging into the surface the monitor is sitting on. The amount of sliding force these spikes can withstand depends upon the amount of downward and sideways force that is on the monitor and the hardness and texture of the surface the spikes are in contact with. At low elevation angles it is difficult for these spikes to resist sliding. These spikes are essential to safe operation of the monitor and must be in contact with the ground at all times. Set the monitor on an even surface so that all three spikes contact the ground. Replace any spike if the tip diameter exceeds 1/16 inch (1.6 mm). Order replacement spike kit: XX482-KIT.

⚠ WARNING

For stable operation the three spikes must maintain in contact with the ground. Do not place the Blitzfire on top of debris, objects, or uneven terrain that would keep any of the spikes from contacting the ground.

⚠ WARNING

On hard slippery surfaces the spikes may provide little resistance to sliding. In these cases the monitor should be tied off or the legs hooked on stationary objects to keep the monitor in position. Also, a person's weight applied to the monitor may help increase resistance to sliding.

⚠ CAUTION

Spikes must be sharp to provide resistance to sliding. Replace any spike if the tip diameter exceeds 1/16 inch (1.6 mm).

⚠ CAUTION

Spikes are sharp and exposed. Use care around spikes to avoid injury and damage to clothing or other property.

2.4 PIVOTING INLET

The Blitzfire has a pivoting inlet so that different size hoses can be used without lifting the spikes off the ground. The pivoting inlet also allows the monitor to be positioned on porches, stair landings, and the like. The pivot moves up and down 20 degrees. The Blitzfire is equipped with three spikes to provide traction when flowing from the ground. For the spikes to provide traction they must remain in contact with the ground. Assure that the hose is not on top of anything that would cause the spikes to lift off the ground. Figure 2.5 shows the inlet pivot's range of motion.

2.5 OUTLET PIVOTS

The Blitzfire's outlet pivots allow for 20 degrees of motion either side of center and elevation between 10 and 50 degrees from horizontal. Push or pull on the nozzle to redirect the stream. The pivots are easy to reposition under pressure and are good for rapid redirecting of the stream. However, if the pivot is rapidly bumped against its travel limit, the Safety Shut-Off Valve may activate and shut off the monitor. Figure 2.5 shows the outlet pivots range of motion.

The Blitzfire has been designed to operate at very low elevation angles to maximize usefulness for interior attack. As with any monitor, when the elevation angle is low the risk of sliding is increased. This is because at low elevation angles the reaction force is more horizontal and less vertical.

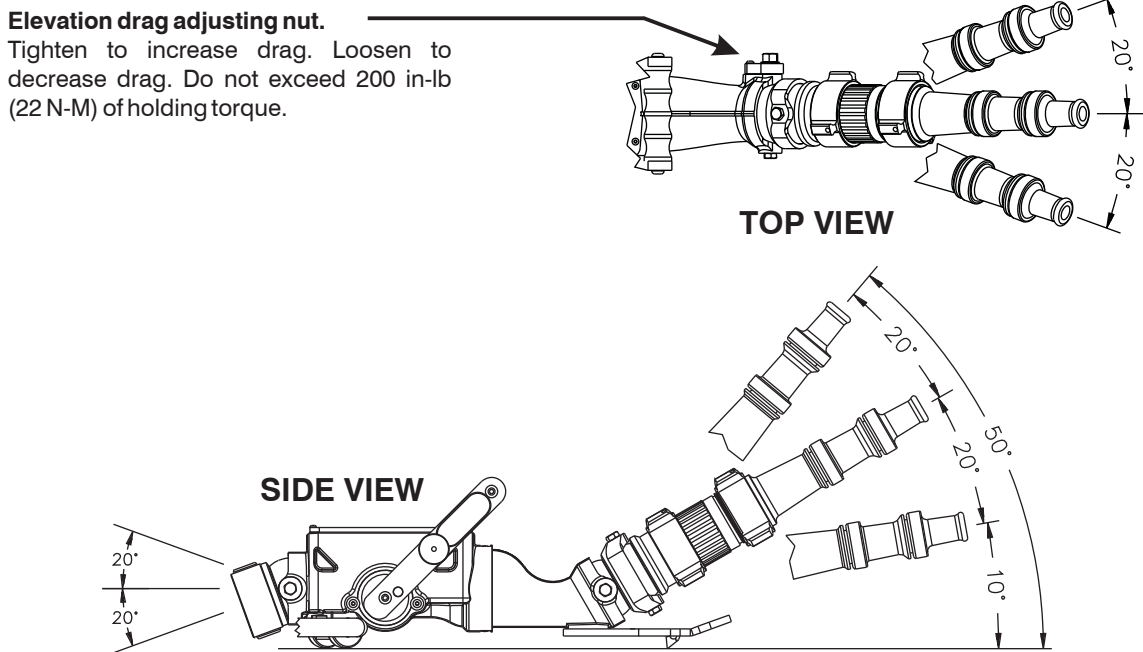

Figure 2.5 Inlet and Outlet pivots Range of Motion

2.5.1 ELEVATION HOLDING MECHANISM

The elevation pivot has a mechanism to support the weight of a nozzle. It is factory set to support the weight of nozzles likely to be used. It may be adjusted (see figure 2.5). The mechanism releases when raising the nozzle so upwards drag from the mechanism is not felt. Avoid the use of long stream straighteners or heavy nozzles which may overcome the holding torque of the elevation mechanism.

3.0 FLOWS AND PRESSURES

The Blitzfire Portable Monitor is designed for maximum flows of 500 GPM (2000 LPM) and a maximum pressure of 175 PSI (12 BAR). Do not exceed these limits.

⚠ WARNING An inadequate supply of pressure and/or flow will cause an ineffective stream and can result in injury, death or loss of property.

3.1 AUTOMATIC, FIXED, AND SELECTABLE FLOW NOZZLES

A variety of water or foam nozzles may be used with the Blitzfire.

Automatic nozzles maintain a constant pressure by adjusting their opening to match the available flow. Consult the nozzle manufacturer for maximum flow and pressure ratings. In all cases do not exceed 500 GPM (2000 LPM) and/or 175 PSI (12 BAR).

3.2 STACKED TIPS OR SMOOTHBORE NOZZLES

| NOZZLE DIAMETER | NOZZLE INLET PRESSURE | | | | | | | | | |
|-----------------|-----------------------|----------------|------------|----------------|------------|----------------|------------|----------------|------------|----------------|
| | 50 PSI | | 80 PSI | | 100 PSI | | 150 PSI | | 175 PSI | |
| | FLOW (GPM) | REACTION (LBS) | FLOW (GPM) | REACTION (LBS) | FLOW (GPM) | REACTION (LBS) | FLOW (GPM) | REACTION (LBS) | FLOW (GPM) | REACTION (LBS) |
| 1.0 INCH | 210 | 80 | 266 | 126 | 297 | 157 | 364 | 236 | 390 | 275 |
| 1-1/4 INCH | 328 | 120 | 415 | 196 | 464 | 245 | — | — | — | — |
| 1-1/2 INCH | 473 | 177 | — | — | — | — | — | — | — | — |

| NOZZLE DIAMETER | NOZZLE INLET PRESSURE | | | | | | | | | |
|-----------------|-----------------------|---------------|--------------|---------------|--------------|---------------|--------------|---------------|--------------|---------------|
| | 4 BAR | | 6 BAR | | 8 BAR | | 10 BAR | | 12 BAR | |
| | FLOW (L/min) | REACTION (KG) | FLOW (L/min) | REACTION (KG) | FLOW (L/min) | REACTION (KG) | FLOW (L/min) | REACTION (KG) | FLOW (L/min) | REACTION (KG) |
| 25 MM | 830 | 40 | 1000 | 60 | 1200 | 80 | 1300 | 100 | 1400 | 120 |
| 32 MM | 1300 | 70 | 1700 | 100 | 1900 | 130 | — | — | — | — |
| 38 MM | 1900 | 90 | — | — | — | — | — | — | — | — |



FLOW EXCEEDS RATING OF BLITZFIRE PORTABLE MONITOR

3.3 STREAM STRAIGHTENERS

Stream quality, especially with smooth bore nozzles, is generally improved with the use of a stream straightener. A stream straightener is integrated into the exit of the monitor.

3.4 USE WITH FOAM

The Blitzfire may be used with various foam nozzles and foam solutions. Refer to fire service training for the proper use of foam.

3.5 USE WITH SALT WATER

Use with salt water is permissible provided the monitor is thoroughly cleaned with fresh water after each use. The service life of the monitor may be shortened due to the effects of corrosion and is not covered under warranty.

3.6 BLITZFIRE PRESSURE LOSS

Figure 3.6 gives the pressure loss for the Blitzfire Portable Monitor

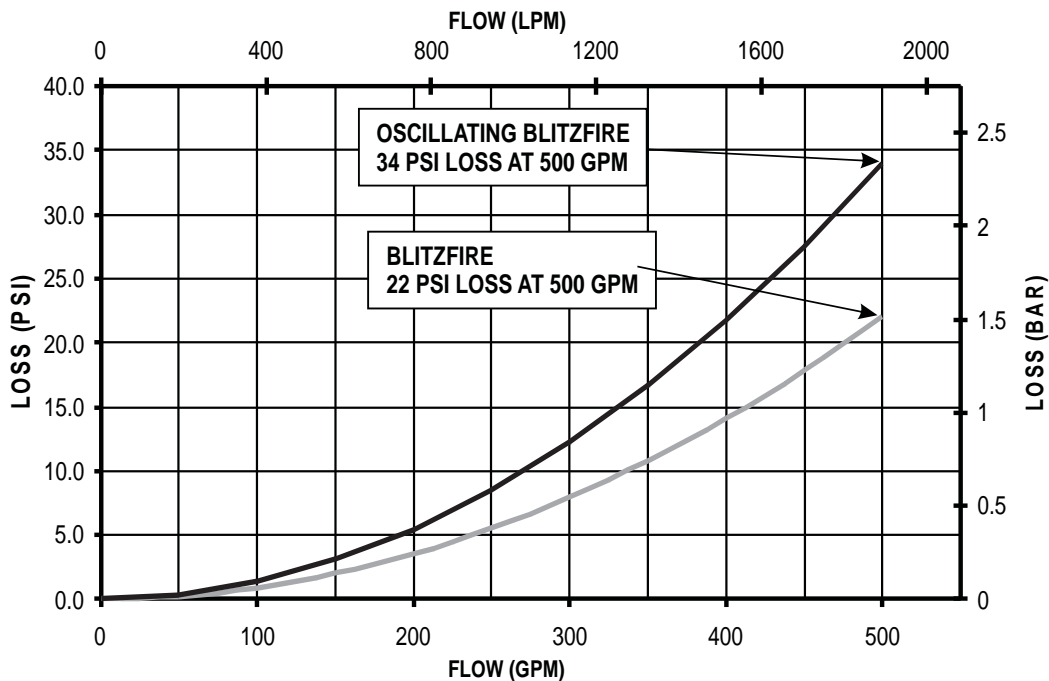

Figure 3.6 Blitzfire Pressure Loss

4.0 DEPLOYMENT OF BLITZFIRE

It is the responsibility of the individual fire department or agency to determine physical capabilities and suitability for an individual's use of this equipment.

4.1 CARRYING WITH AN UNCHARGED HOSE

On a preconnected hoseline the Blitzfire may be carried over the shoulder with the legs folded as illustrated in figure 4.1.



Figure 4.1 Carrying the Blitzfire on an Uncharged Hose

4.2 ADVANCING WITH A CHARGED HOSE

On a charged hose the Blitzfire may be advanced by holding the valve handle and one of the legs as shown in figure 4.2. Valve handle should be locked in the closed position to keep the valve from inadvertently opening.

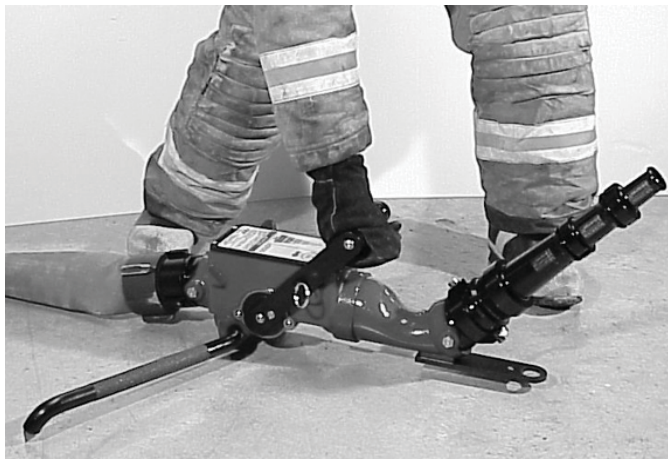

Figure 4.2 Advancing the Blitzfire with a Charged Hose

5.0 ANCHORING

The nozzle reaction force on the Blitzfire may be as high as 330 lbs - 500 GPM at 175 PSI (150 kg- 2000 LPM at 12 BAR). This nozzle reaction must be restrained to keep the monitor from moving.

The monitor should be anchored from moving by one or more of these methods:

| METHOD | RISK of MOVING |
|-----------------------------------|----------------|
| Anchoring by Weight | High |
| Anchoring by Spike Holds | Medium |
| Hooking legs on vertical surfaces | Medium |
| Using a tie off strap | Low |

5.1 ANCHORING BY WEIGHT

On surfaces with good traction a person's weight on the monitor and/or hose may be sufficient to keep the monitor from moving. This is highly dependant on the friction of the surface. The ability to keep one or more than one person's weight on the monitor is subject to operator fatigue and may not be as reliable as other methods. Operating at limited flows will reduce the risk.

5.2 ANCHORING BY SPIKE HOLDS

Anchoring by spike holds is defined as intentionally placing one or more spikes into a crack, hole, or other hold to anchor the monitor from moving. On hard smooth surfaces such as ceramic tile, smooth concrete, marble, terrazzo, or steel decking the Blitzfire's spikes may not hold well. Placing the spikes into cracks, expansion joints, or gratings or the like will help hold the monitor from sliding. Even with the spikes anchored, sliding may be caused by the surface cracking under the load, or from the hose or nozzle moving the monitor thereby dislodging the spikes from their hold. Figure 4.3.1 shows a close up of a spike caught in a crack.

The holding ability of the spikes on soft surfaces such as sand, gravel and mud is generally poor, therefore other anchoring methods should be considered.

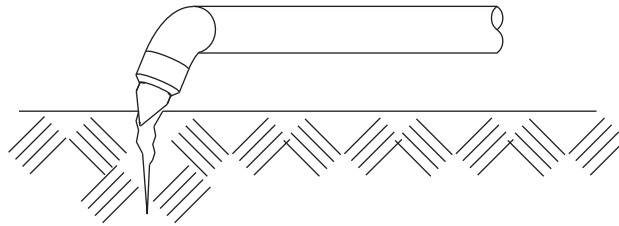
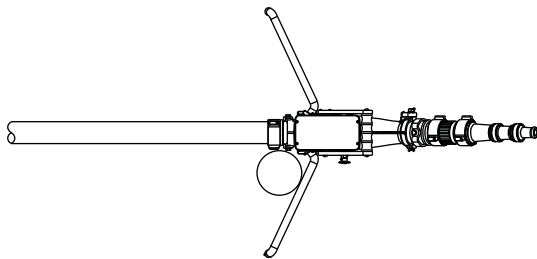

Figure 4.3.1 Spike Caught in a Crack

5.3 ANCHORING BY HOOKING LEGS

The legs on the Blitzfire point back slightly so they can act as a hook for anchoring on posts, walls, door frames or other fixed objects. Sliding can occur if the legs are unhooked due to the influence of the hose, nozzle, or operator. See figure 4.3.2 for illustrations of hooking the legs.



Good
Nozzle reaction keeps leg hooked.
Object is close to hose.

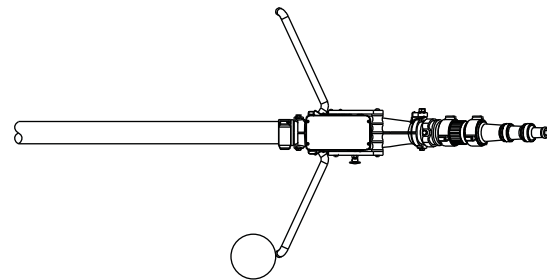

Poor
Nozzle reaction tends to unhook leg

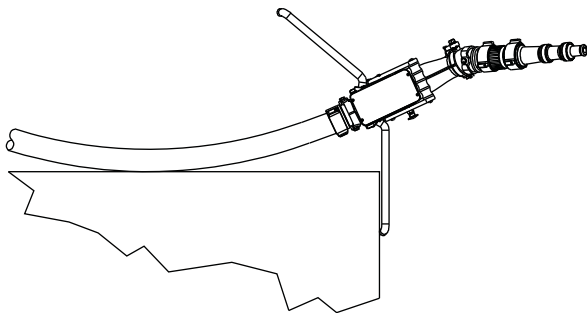

Good
Nozzle reaction keeps leg hooked.
Hose hits wall and helps hold position.

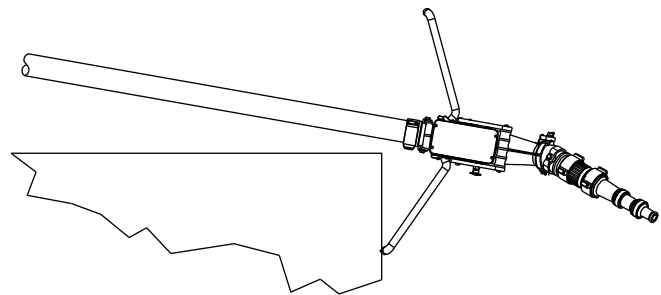

Poor
Nozzle reaction tends to unhook leg.

Figure 5.3 Hooking Legs to Gain Support

5.4 ANCHORING BY TYING OFF

The safest method of restraining the monitor is to use a tie down strap. It is inherently more reliable than other methods since it does not rely on traction or digging in of the spikes. It is also the safest method because, even if the monitor moves, its travel is limited by the strap. A forward attachment point and a strap are provided with the Blitzfire. A loop on the end of the strap may be placed over the anchor point or the strap may be wrapped around an object, such as a tree, and the snap end of the strap passed through the loop and pulled tight. Keep the entire length of the strap as close to the ground as possible. Snap the hook into the hole in the front of the Blitzfire. If the strap is too short to reach a suitable anchor, it may be extended with strong rope or chain. Keep the distance between the Blitzfire and anchor as short as possible. Remove all slack between the Blitzfire and anchor before flowing water. Figure 4.3.3 shows the elements of tying off the monitor.

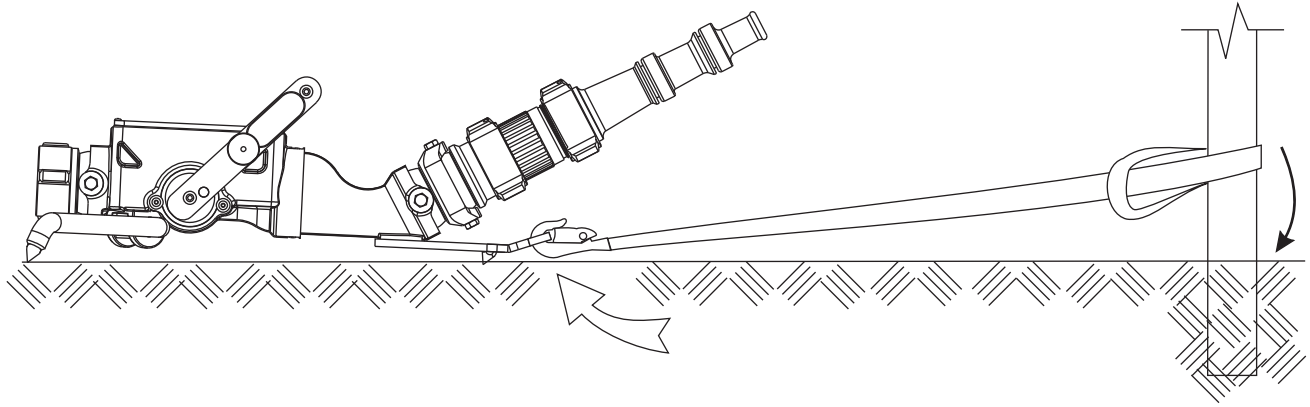

Figure 4.3.3 Tying Off of Blitzfire Monitor

6.0 OSC OSCILLATING UNIT

An automatic oscillating mechanism is available for the Blitzfire Monitor. The Blitzfire Monitor can be purchased with the oscillating mechanism factory installed or added at the factory later.

6.1 SAFETY - OSCILLATOR

⚠ DANGER

Do not attempt to modify this oscillating mechanism to fit any other monitor. To do so will cause the reaction force of the nozzle to be unaligned with the center of rotation. The monitor may spin very fast with a very high force.

⚠ WARNING

Keep hands and fingers away from the moving parts of the oscillating unit when water is flowing. There are moving parts that can pinch fingers and hands. Keep the guard in place.

⚠ WARNING

Make sure the Blitzfire is on a firm surface with adequate holding power. As the nozzle goes back and forth, the reaction force is acting in different directions on the leg spikes. Surfaces such as asphalt, turf and dirt generally have good holding power. Surfaces like concrete and loose gravel hold poorly.

⚠ CAUTION

Because the nozzle attached to the Blitzfire must slow down, stop and reverse direction at the end of each sweep, the ends of the covered area will receive more water than the center. If the center area of coverage needs the most cooling, occasionally narrow the area of coverage or use the oscillator manually.

6.2 GENERAL - OSCILLATOR

The Blitzfire oscillating mechanism can be used for exposure protection, cooling, or any other situation where it is desirable to have a monitor sweep back and forth. Like the standard Blitzfire, the oscillator operates between 10 and 50 degrees above the horizontal and 20 degrees either side of center. Flow and pressure ratings are the same as the standard Blitzfire. The oscillating Blitzfire also has the same trip mechanism as the standard unit.

The oscillating mechanism is driven by a turbine wheel. A worm gear drive reduces the speed and increases the torque of the turbine wheel. A simple crank mechanism makes the outlet of the Blitzfire and the nozzle attached to it move back and forth. The horizontal sweep can be set for a 20, 30 and 40 degree sweep. The oscillating mechanism can be uncoupled and the water stream can be aimed manually. Elevation angle is set the same as the standard Blitzfire.

The speed of oscillation is a function of flow rate, see the Blitzfire Oscillation Speed graph on page 14.

6.3 CONTROL IDENTIFICATION - OSCILLATOR

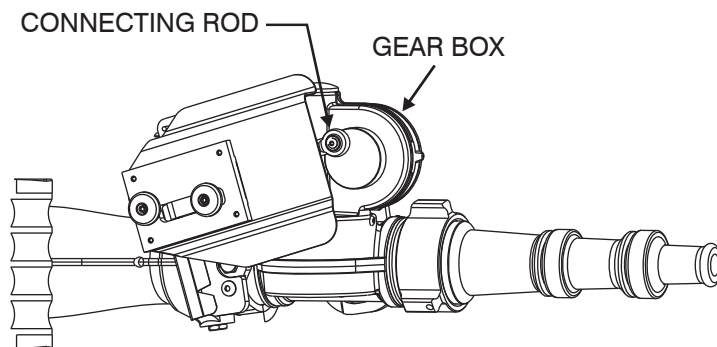
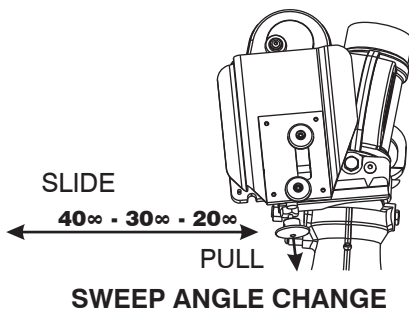
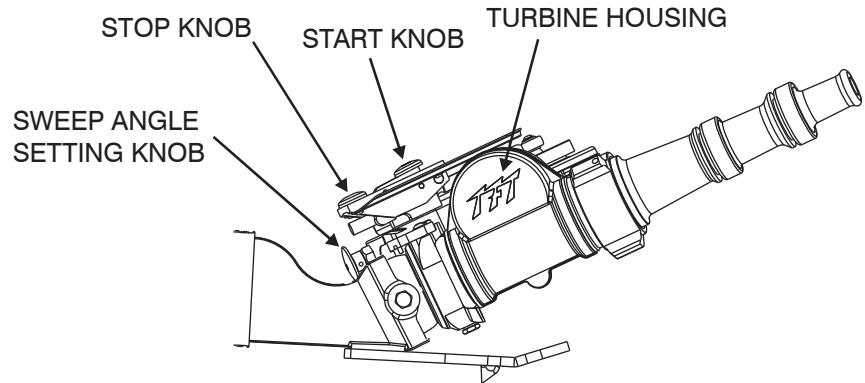
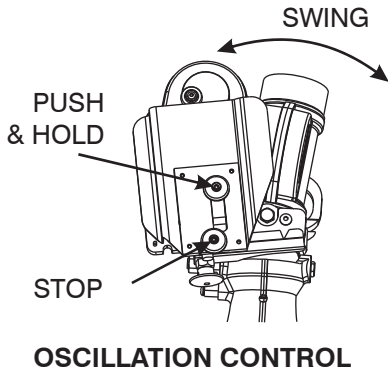

6.4 USE - OSCILLATOR

Deploy the Oscillation Blitzfire as you would the standard Blitzfire, see section 4.0. Align the base of the Blitzfire with the center of the area you wish to cover.

To Engage The Oscillating Mechanism: If the nozzle moves freely left to right by hand, the oscillating mechanism is not engaged. Depress the green START KNOB and move the nozzle from one side to the other until the roll pin drops in the groove in the connecting rod. Open the valve on the Blitzfire and adjust the elevation to hit the desired spot. The minimum flow is 175 GPM (650 L/min). To adjust the area of coverage, pull the silver knob and move it left or right until the pointer aligns with the desired angle of coverage.

To Disengage The Oscillating Mechanism: To operate the oscillating Blitzfire Manually, depress the Red STOP KNOB and move the Nozzle to the desired position by hand. The green START KNOB will pop up to indicate the mechanism is disengaged. The crank and connecting rod will continue to move.

To protect the gears from overload, the oscillating mechanism will disengage if sufficient force is applied to either side of the oscillator outlet. The green START KNOB will pop up to indicate the mechanism is disengaged. See the instructions above to engage the drive mechanism.

Oscillation speed: The chart shows how many times per minute the oscillator makes one complete cycle as a function of flow. The higher the flow, the faster it oscillates.

| APPROXIMATE CYCLES/MIN | GPM | L/MIN |
|------------------------|-----|-------|
| 8 | 175 | 650 |
| 13 | 250 | 1000 |
| 21 | 375 | 1500 |
| 28 | 500 | 2000 |

BLITZFIRE OSCILLATION SPEED

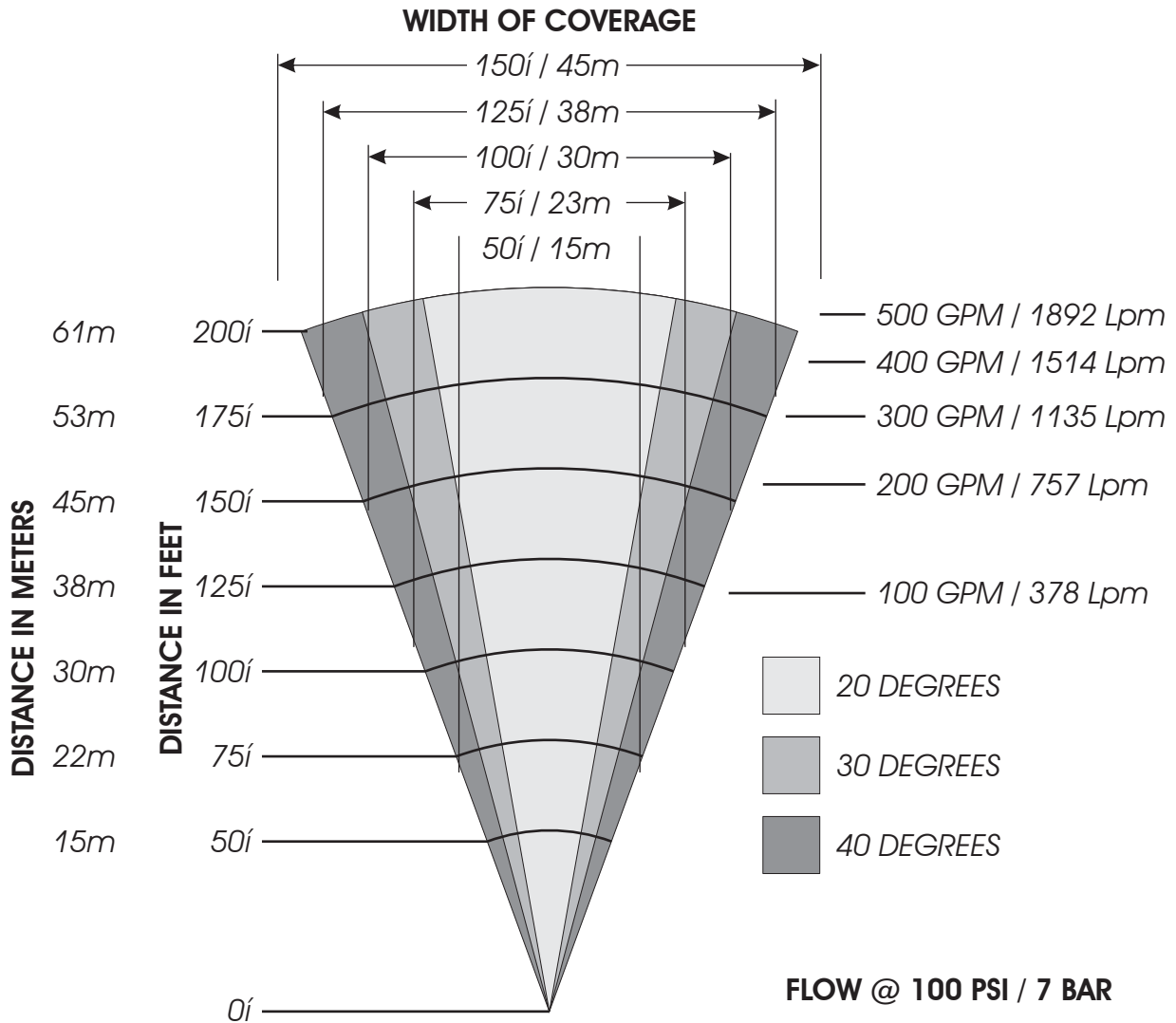

COVERAGE AREA OF BLITZFIRE OSCILLATING UNIT

7.0 STORAGE

The monitor may be stored pre-connected to its hose on the optional storage bracket, TFT part number XX-B. The storage bracket may be mounted on a horizontal surface, or a vertical surface with the nozzle end pointing up or sideways. Mounting instructions are included with the bracket.



The storage bracket is not intended to support the nozzle reaction forces from a flowing monitor.

8.0 MAINTENANCE

The Blitzfire monitor requires little maintenance. The unit should be kept clean and free of dirt by rinsing with water after each use. Any inoperable or damaged part should be repaired or replaced.



Any alterations to the Blitzfire and its markings could diminish safety and constitutes a misuse of this product.

MAINTENANCE CHECK LIST:

- Safety shut-off valve is operational (see section 2.2.3)
- Valve label legible
- Legs pivot freely and detents hold folded or unfolded position
- Spikes are sharp. Replace if tip diameter exceeds 1/16 inch (1.6 mm).
- Inlet coupling rotates freely
- Inlet pivots freely up and down
- Pull pin for Valve Handle locking locks and releases easily
- Valve Handle moves smoothly without binding
- Valve Handle stays in detent positions
- Outlet pivots freely from side to side
- Outlet pivots freely upward
- Outlet pivot has sufficient drag to support weight of nozzle
- Tie down strap is in good condition; no frays on strap or damage to hook

9.0 WARRANTY

Task Force Tips, Inc., 3701 Innovation Way, Valparaiso, Indiana 46383-9327 USA ("TFT") warrants to the original purchaser of its Blitzfire Monitor ("equipment"), and to anyone to whom it is transferred, that the equipment shall be free from defects in material and workmanship during the five (5) year period from the date of purchase.

TFT's obligation under this warranty is specifically limited to replacing or repairing the equipment (or its parts) which are shown by TFT's examination to be in a defective condition attributable to TFT. To qualify for this limited warranty, the claimant must return the equipment to TFT, at 3701 Innovation Way, Valparaiso, Indiana 46383-9327 USA, within a reasonable time after discovery of the defect. TFT will examine the equipment. If TFT determines that there is a defect attributable to it, it will correct the problem within a reasonable time. If the equipment is covered by this limited warranty, TFT will assume the expenses of repair.

If any defect attributable to TFT under this limited warranty cannot be reasonably cured by repair or replacement, TFT may elect to refund the purchase price of the equipment, less reasonable depreciation, in complete discharge of its obligations under this limited warranty. If TFT makes this election, claimant shall return the equipment to TFT free and clear of any liens and encumbrances.

This is a limited warranty. The original purchaser of the equipment, any person to whom it is transferred, and any person who is an intended or unintended beneficiary of the equipment, shall not be entitled to recover from TFT any consequential or incidental damages for injury to person and/or property resulting from any defective equipment manufactured or assembled by TFT. It is agreed and understood that the price stated for the equipment is in part consideration for limiting TFT's liability. Some states do not allow the exclusion or limitation of incidental or consequential damages, so the above may not apply to you.

TFT shall have no obligation under this limited warranty if the equipment is, or has been, misused or neglected (including failure to provide reasonable maintenance) or if there have been accidents to the equipment or if it has been repaired or altered by someone else.

THIS IS A LIMITED EXPRESS WARRANTY ONLY. TFT EXPRESSLY DISCLAIMS WITH RESPECT TO THE EQUIPMENT ALL IMPLIED WARRANTIES OF MERCHANTABILITY AND ALL IMPLIED WARRANTIES OF FITNESS FOR A PARTICULAR PURPOSE. THERE IS NO WARRANTY OF ANY NATURE MADE BY TFT BEYOND THAT STATED IN THE DOCUMENT.

This limited warranty gives you specific legal rights, and you may also have other rights which vary from state to state.

Visit TFT's web site at www.tft.com

10.0 EXPLODED VIEWS AND PARTS LISTS

10.1 SAFETY MECHANISM ASSEMBLY VIEW

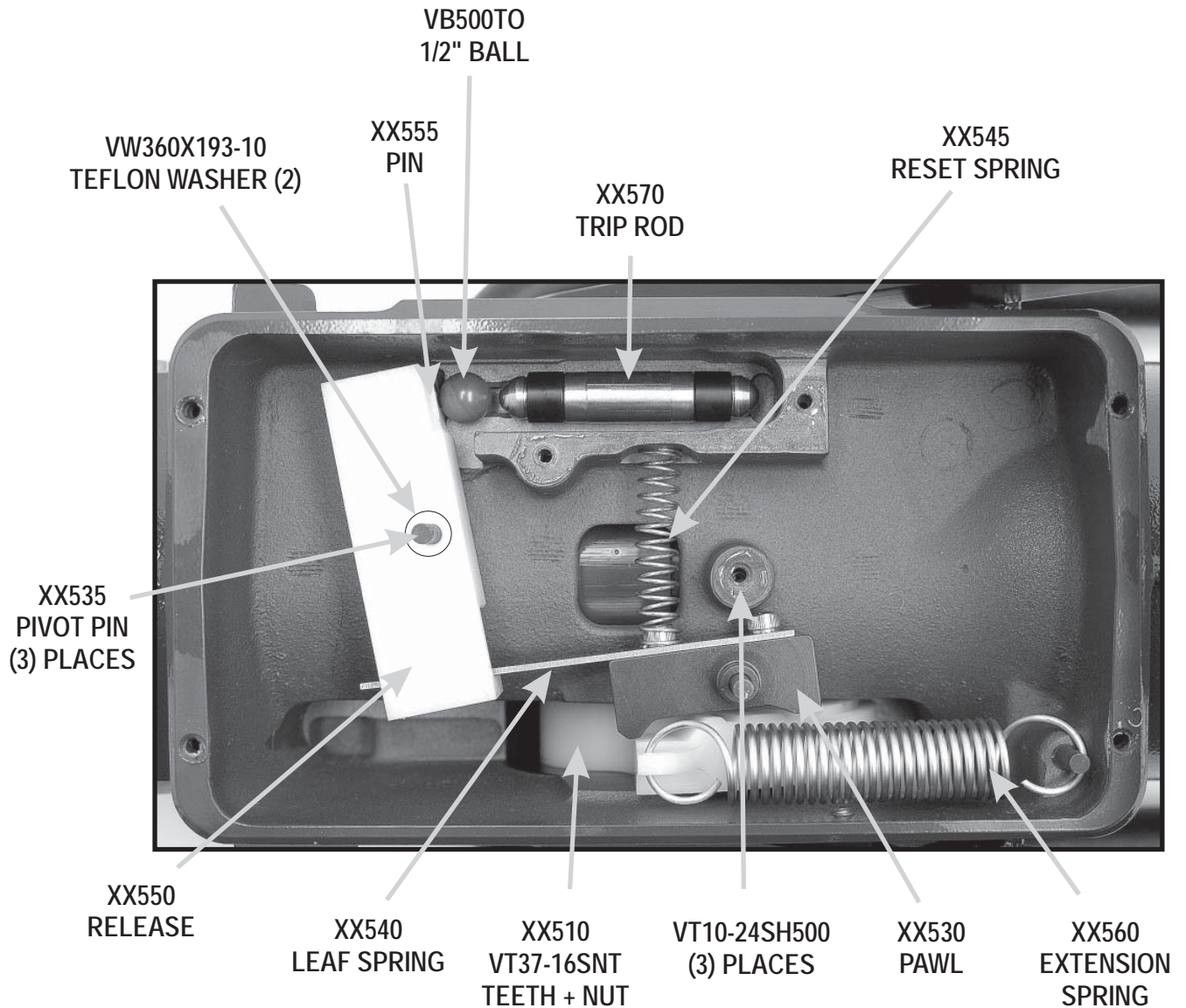

NOT SHOWN: XX520 RETAINER PLATE
VP188X.38HDP SPIRAL PIN

10.2 BLITZFIRE MONITOR EXPLODED VIEW

For repair information on the automatic shutoff or the slow close mechanism, contact Task Force Tips at 800-348-2686.

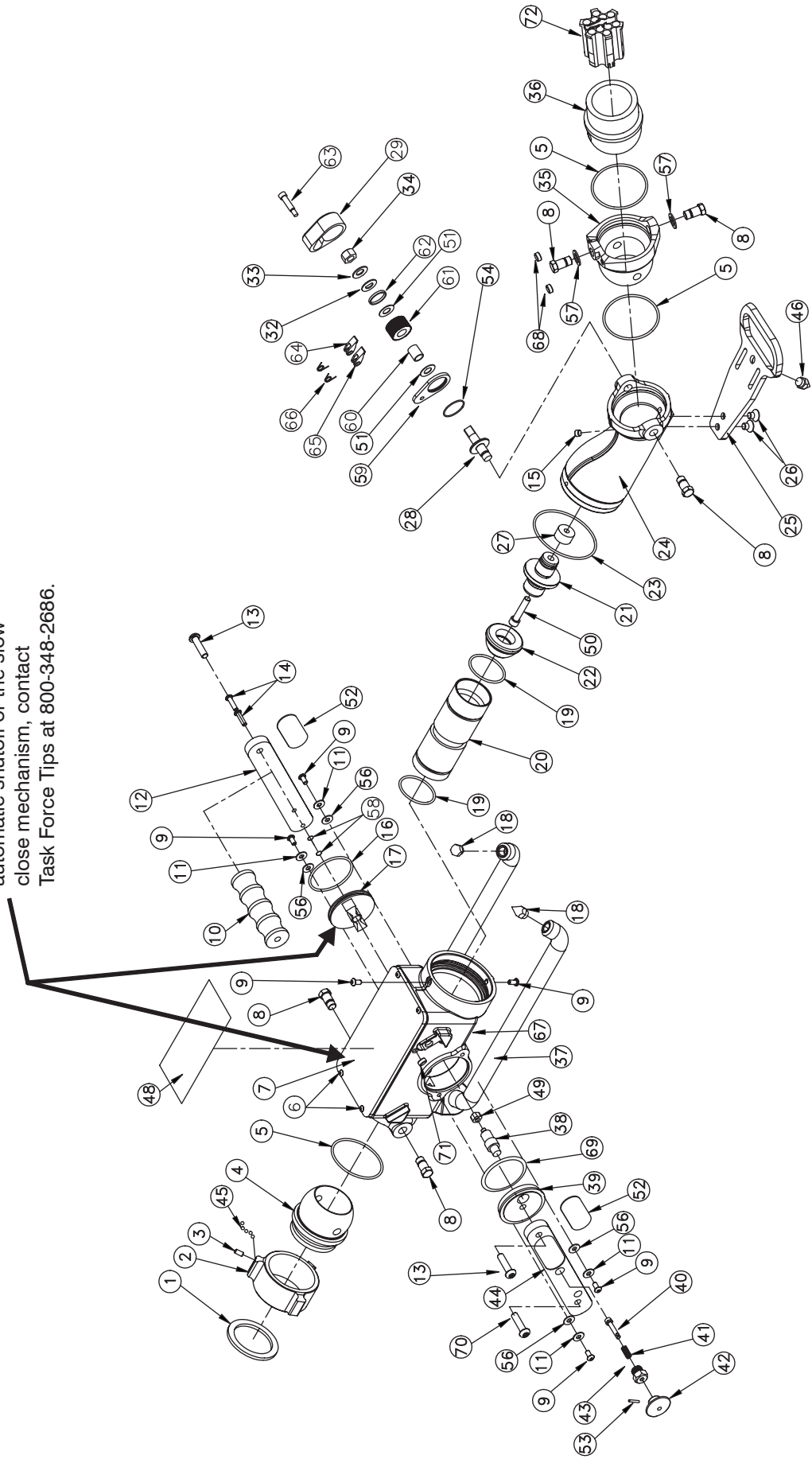

| INDEX | DESCRIPTION | QTY | ITEM # |
|-------|-------------------------------------|-----|--------------|
| 1 | 2.5 INCH COUPLING GASKET | 1 | V3190 |
| 2* | 2.5 NH COUPLING ROCKERLUG | 1 | M307N |
| 3 | 1/4-28 X 1/2 SOCKET SET SCREW | 1 | VT25-28SS500 |
| 4 | INLET SWIVEL | 1 | XX605 |
| 5 | O-RING-235 | 3 | VO-235 |
| 6 | 10-24 1/2 BUTTON HEAD SCREW | 4 | VT10-24BH500 |
| 7 | COVER PLATE | 1 | XX205 |
| | COVER PLATE GASKET | 1 | XX200 |
| 8 | SWIVEL TRUNNION | 5 | XX320 |
| 9 | 1/4-28 X 1/2 BUTTON HEAD SCREW | 6 | VT25-28BH500 |
| 10 | HANDLE TOP | 1 | XX625 |
| 11 | STAINLESS WASHER 1/4" | 4 | VW687X281-50 |
| 12 | LEFT HANDLE | 1 | XX621 |
| 13 | 3/8-16 X 1.5 BUTTON HEAD SCREW | 2 | VT37-16BH1.5 |
| 14 | 1/4-20 X 1.0 BUTTON HEAD SCREW | 2 | VT25-20BH1.0 |
| 15 | 1/8 NPT PLUG | 1 | VFSP1M S |
| 16 | QUAD RING 4231 | 1 | VOQ-4231 |
| 17 | DRAG DISK | 1 | XX645 |
| 18 | REAR SPIKE | 2 | X482 |
| 19 | O-RING-227 | 2 | VO-227 |
| 20 | SLIDER | 1 | XX660 |
| 21 | PLUG SUPPORT | 1 | XX594 |
| 22 | VALVE PLUG | 1 | XX590 |
| 23 | O-RING-241 | 1 | VO-241 |
| 24 | OUTLET | 1 | XX420 |
| 25 | FRONT LEG | 1 | XX460 |
| 26 | 3/8-16 X 1/2 FLAT HEAD SOCKET SCREW | 2 | VT37-16FH750 |
| 27 | LOCKING SLEEVE | 1 | XX571 |
| 28 | CLUTCH TRUNION | 1 | XX325 |
| 29 | CLUTCH HOUSING | 1 | XX337 |
| 32 | D-WASHER | 1 | XX350 |
| 33 | BELLEVILLE WASHER | 1 | VW1.0X512-BV |
| 34 | 1/2-20 HEX NUT | 1 | VT50-20NT |
| 35 | EXIT SEGMENT | 1 | XX305 |
| 36 | EXIT 2.5" | 1 | XX310* |

* Consult Factory For Special Threads.

| INDEX | DESCRIPTION | QTY | ITEM # |
|-------|-------------------------------------|-----|--------------|
| 37 | LEG ASSEMBLY | 1 | XX905 |
| 38 | CAM PIN | 1 | XX610 |
| 39 | DISK | 1 | XX640 |
| 40 | PULL PIN | 1 | XX343 |
| 41 | PULL PIN SPRING | 1 | XX342 |
| 42 | PULL KNOB | 1 | XX341 |
| 43 | PULL PIN HOUSING | 1 | XX355 |
| 44 | RIGHT HANDLE | 1 | XX620 |
| 45 | 3/16" SS BALL | 48 | V2120 |
| 46 | SPIKE | 1 | X480 |
| 48 | INSTRUCTION LABEL | 1 | XL670 |
| 49 | SQUARE BUSHING | 1 | XX630 |
| 50 | 3/8-24 X 1.75 SOCKET HEAD CAP SCREW | 1 | VT37-24SH175 |
| 51 | FLAT WASHER - PHENOLIC | 2 | VW1.0X500-03 |
| 52 | HANDLE LABEL | 2 | XL620 |
| 53 | PIN 1/8 X 3/4 | 1 | VP125X750H |
| 54 | O-RING -027 | 1 | VO-027 |
| 56 | DISC RETAINER | 4 | XX642 |
| 57 | WAVE SPRING WASHER .74 O.D. | 2 | VW740X550-16 |
| 58 | O-RING -109 | 2 | VO-109 |
| 59 | CLUTCH BASE | 1 | XX336 |
| 60 | NYLON BUSHING | 1 | XX334 |
| 61 | RATCHET | 1 | XX333 |
| 62 | DIRT SEAL | 1 | XX339 |
| 63 | 5/16 X 1 SOCKET HEAD SHOULDER | 1 | VT31-00SB1.0 |
| 64 | PAWL 40 DEGREE | 1 | XX331 |
| 65 | PAWL 37 1/2 DEGREE | 1 | XX332 |
| 66 | TORSION SPRING | 2 | XX338 |
| 67 | BODY | 1 | XX600 |
| | TRIP MECHANISM | 1 | XX910 |
| 68 | 5/16-18 X 1/4 SOCKET SET SCREW | 2 | VT31-18SS250 |
| 69 | O-RING-230 TEFLON | 1 | VO-230T |
| 70 | 3/8-16 X 1.7 BUTTON HEAD SCREW | 1 | VT37-16BH1.7 |
| 71 | 10-24 X 1/4 SOCKET SET SCREW | 1 | VT10-24SS250 |
| 72 | EXIT FIN INSERT ASSEMBLY | 1 | XXL812 |

10.3 OSCILLATOR EXPLODED VIEW

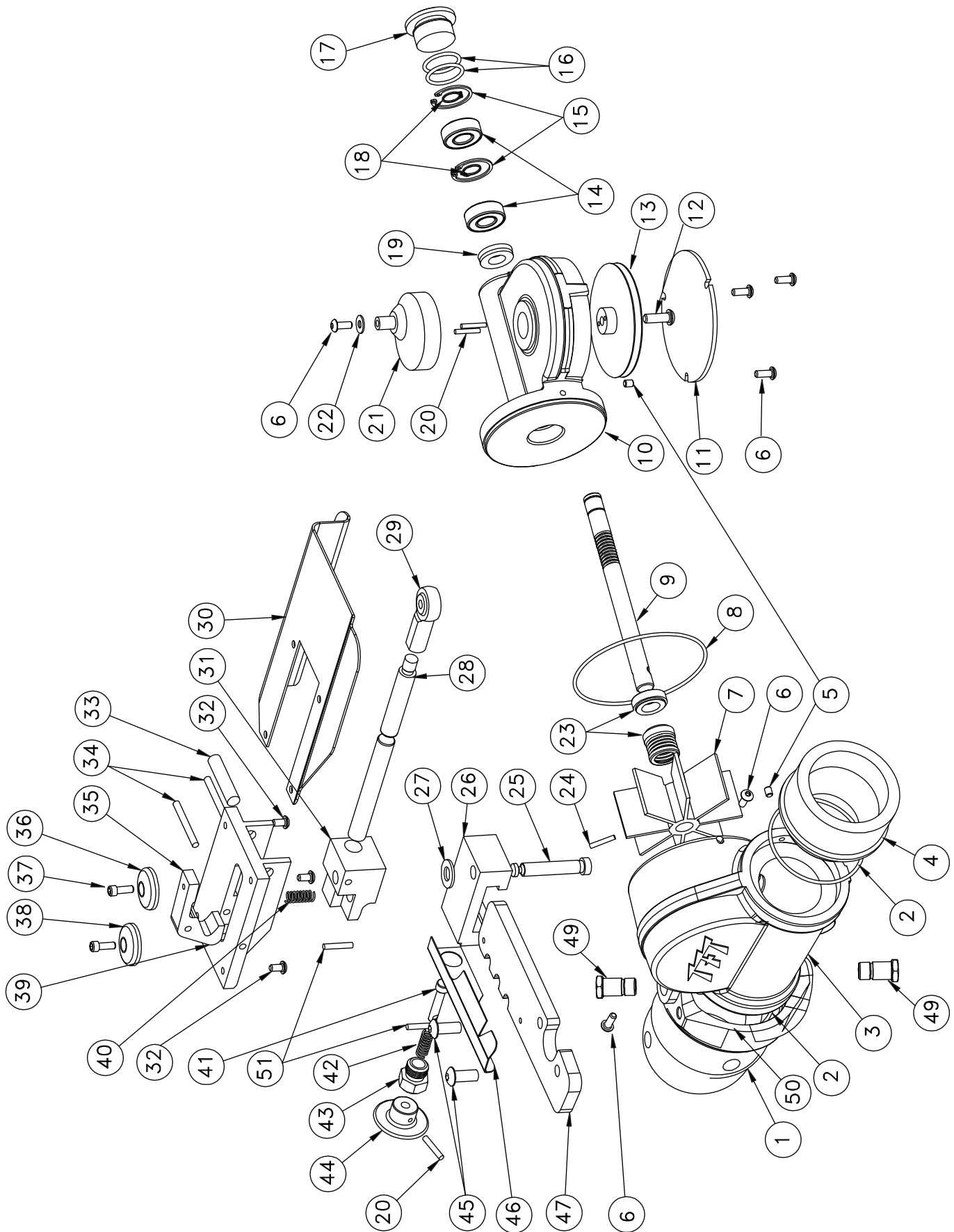

| INDEX | DESCRIPTION | QTY | ITEM # |
|-------|---------------------------------------|-----|--------------|
| 1 | INLET BALL HARDCOAT | 1 | XX015 |
| 2 | 147 O-RING | 2 | VO-147 |
| 3 | WATERWAY DK BLUE POWDERCOAT | 1 | XX010 |
| 4 | EXIT 2.5* -HARDCOAT | 1 | XX020 * |
| 5 | 10-32 X ¼ SOCKET SET SCREW STAINLESS | 2 | VT10-32SS250 |
| 6 | 10-32 X ½ BUTTON HEAD SCREW STAINLESS | 6 | VT10E32BH500 |
| 7 | TURBINE VANES HARDCOAT | 1 | XX025 |
| 8 | 153 O-RING | 1 | VO-153 |
| 9 | WORM AND SHAFT | 1 | XX030 |
| 10 | GEAR BOX DK BLUE POWDERCOAT | 1 | XX005 |
| 11 | COVER | 1 | XX045 |
| 12 | ¼-20 X 7/8 STAINLESS SOCKET CAP SCREW | 1 | VT25-20SH875 |
| 13 | WORM GEAR | 1 | XX040 |
| 14 | WORM SHAFT BEARING | 2 | XX035 |
| 15 | SNAP RING 1-1/8 INTERNAL X .05 | 2 | VR4255 |
| 16 | 119 O-RING | 2 | VO-119 |
| 17 | SHAFT CAP | 1 | XX037 |
| 18 | SNAP RING ½* EXTERNAL X .035 | 2 | VR4250 |
| 19 | CUP SEAL 1 OD X .5 ID X ¼ WIDE BUNA N | 1 | XX033 |
| 20 | 1/8 X ¼ SPIROL PIN | 3 | VP125X750H |
| 21 | CRANK HARDCOAT | 1 | XX050 |
| 22 | #10 WASHER | 1 | VW500X203-60 |
| 23 | TURBINE SEAL | 1 | XX032 |
| 24 | 5/32 X 7/8 HDP SPIROL PIN #12437 | 1 | V1900 |

* Consult Factory For Special Threads.

| INDEX | DESCRIPTION | QTY | ITEM # |
|-------|-------------------------------------|-----|--------------|
| 25 | SLIDE PIVOT MACHINED | 1 | XX067 |
| 26 | ARM SLIDE HARDCOAT | 1 | XX065 |
| 27 | WASHER | 1 | VW812X406-65 |
| 28 | LINK MACHINED | 1 | XX055 |
| 29 | ROD END | 1 | XX056 |
| 30 | GUARD | 1 | XX077 |
| 31 | LINK SLIDE HARDCOAT | 1 | XX066 |
| 32 | 10-32 X 3/8 BUTTON HEAD CAP SCREW | 4 | VT10-32BH375 |
| 33 | 3/8 X 1-3/4 STAINLESS PIN | 1 | XX081 |
| 34 | 3/16 X 1-3/4 STAINLESS PIN | 2 | XX080 |
| 35 | LINK TRIGGER MACHINED | 1 | XX075 |
| 36 | PALM BUTTON GREEN | 1 | XX072-GRN |
| 37 | 10-32 X 1/2 SOCKET HEAD CAP SCREW | 2 | VT10-32SH500 |
| 38 | PALM BUTTON RED | 1 | XX072-RED |
| 39 | LINK RELEASE | 1 | XX070 |
| 40 | RELEASE SPRING | 1 | XX071 |
| 41 | PULL PIN | 1 | XX340 |
| 42 | PULL PIN SPRING | 1 | XX342 |
| 43 | PULL PIN HOUSING | 1 | X350 |
| 44 | PULL KNOB | 1 | XX341 |
| 45 | 5/16-18 X 5/8 BUTTON HEAD CAP SCREW | 2 | VT31-18BH625 |
| 46 | INDICATOR | 1 | XX068 |
| 47 | ARM | 1 | XX060 |
| 48 | NAME LABEL - OSCILLATOR | 1 | XL610 |
| 49 | SWIVEL TRUNION | 2 | XX320 |
| 50 | EXIT SEGMENT | 1 | XX305 |
| 51 | 5/32 x 1/2 SPIROL PIN | 2 | V1905 |

11.0 OPERATION CHECKLIST

Monitor must be inspected for proper operation and function according to this checklist before each use. Before flowing water check:

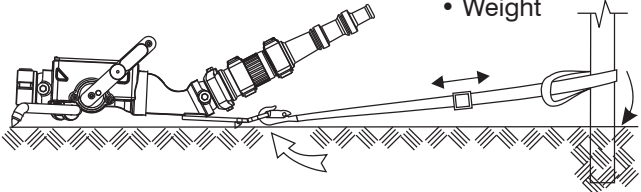
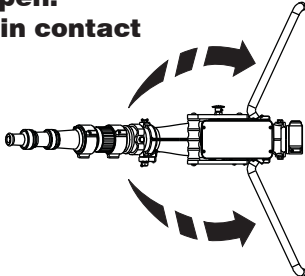
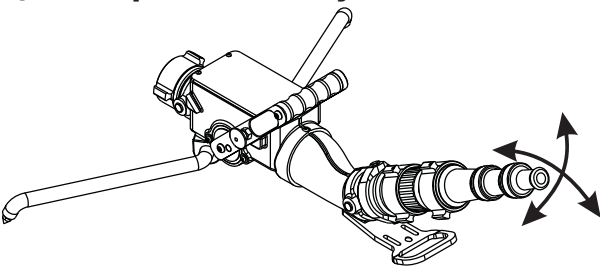
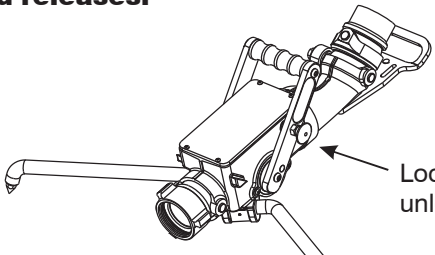
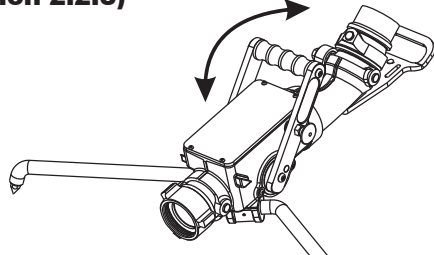
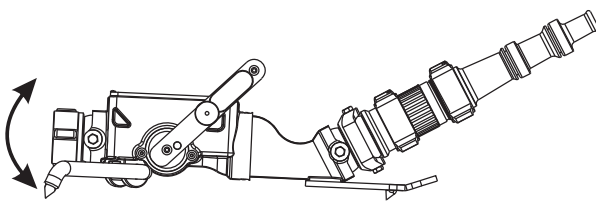
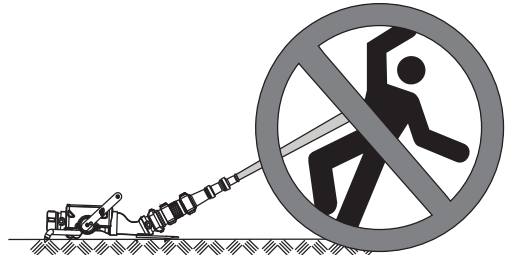
| | |
|--|---|
| <p>1) There is no obvious damage such as missing, broken or loose parts. 2) Hose and nozzle are securely attached.</p> | <p>7) Monitor is anchored:</p> <ul style="list-style-type: none"> • Tied off • Hooked leg • Spike hold • Weight  |
| <p>3) Both legs are fully open. 4) All three spikes are in contact with the ground.</p>  | <p>8) Outlet pivots smoothly in all directions.</p>  |
| <p>5) Valve handle locks when closed and releases.</p>  <p style="text-align: right;">Locks and unlocks</p> | <p>9) Safety Shut-Off valve is operational. (see section 2.2.3)</p>  |
| <p>6) Inlet pivots freely.</p>  | <p>10) Monitor is pointed in a safe direction.</p>  |

⚠ WARNING Any Blitzfire monitor failing any part of the inspection checklist is unsafe and must have the problem corrected before use. Operating a Blitzfire that fails any of the above inspections is a misuse of this equipment.

TASK FORCE TIPS, INC.
 MADE IN USA • www.tft.com

3701 Innovation Way, Valparaiso, IN 46383-9327 USA
 800-348-2686 • 219-462-6161 • Fax 219-464-7155