



# EXTEND-A-GUN™ RC3 & RC4

Telescoping Waterway for Deck Mounted Monitors  
For use with Serial #'s above X505163

## INSTRUCTIONS FOR INSTALLATION, SAFE OPERATION AND MAINTENANCE

**⚠ DANGER**

Read instruction manual before use. Operation of this device without understanding the manual and receiving proper training is a misuse of this equipment. A person who has not read and understood all operating and safety instructions, is not qualified to operate the Extend-A-Gun RC3 or RC4 telescoping unit.

### CONTROL BOX

(complete with 10 ft (3m) of power & communication cable for connection to monitor communication link & power, 12 ft (3m) of cable for connection to RC monitor, and 12 ft (3.6m) of cable for connection to RC Extend-A-Gun motor)

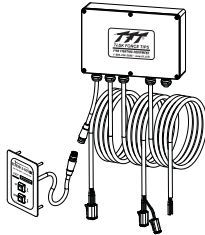

### OPTIONAL PUSHBUTTON STATION

(complete with 12 ft (3.6m) cable for connection to control box)

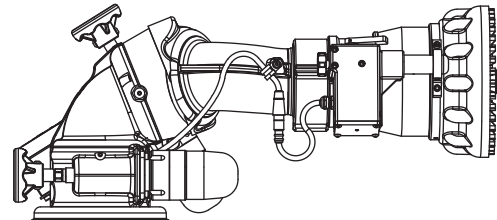

Shown with  
Monsoon RC Monitor  
and Master 2000 Nozzle.  
(Monitor, Nozzle and  
Mounting Brackets not included)

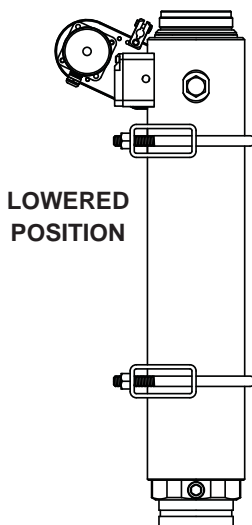

LOWERED  
POSITION

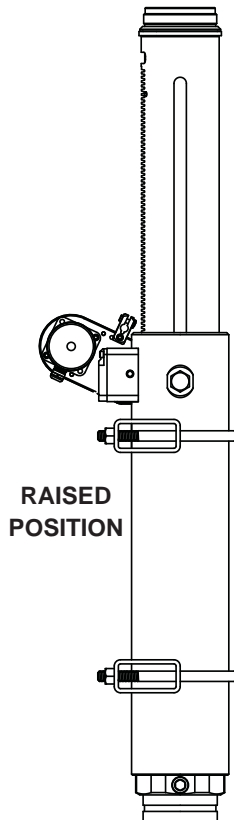

RAISED  
POSITION

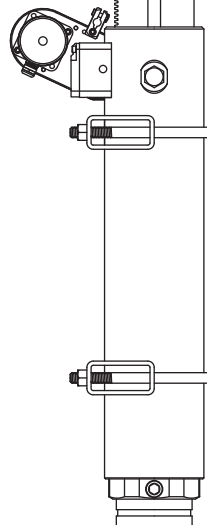

**TASK FORCE TIPS, INC.**  
MADE IN USA • [www.tft.com](http://www.tft.com)

3701 Innovation Way, Valparaiso, IN 46383-9327 USA  
800-348-2686 • 219-462-6161 • Fax 219-464-7155

## Table Of Contents

1.0	Meaning Of Safety Signal Words	8.0	Retracted & Extended Relay Wiring
2.0	Safety	8.1	Indicator Light Mounting & Wiring
3.0	General Information	9.0	Labels
3.1	Specifications	10.0	Mounting Monitor
3.2	Parts Identification	10.1	Tornado, Hurricane, Typhoon and Monsoon
3.3	Dimensions	10.2	Crossfire® On Extend-a-gun RC3
4.0	Bracket Sets	11.0	Use Of Drain
4.1	Selection Of Structural Support On Fire Trucks	12.0	Operating Instructions
4.2	Tube Bracket Installation	12.1	Extend
4.3	Saddle Bracket Installation	12.2	Retract
4.4	Plate Bracket Installation	12.3	Manual Override
5.0	Side Loads At Mounting Points	12.4	Indicator Light
5.1	12" Extend-A-Gun RC3	12.5	Operation Below Freezing Temperatures
5.2	18" Extend-A-Gun RC3 & RC4	12.6	Continuous Operations
6.0	Manual Override	12.7	Current Limiting
6.1	Removing Manual Override Knob	12.8	Use With Salt Water
7.0	Control Box Installation	13.0	Trouble Shooting
7.1	Control Box Mounting	14.0	Maintenance and Inspection
7.2	Panel Mount Operator Station Mounting	14.1	Lubrication
7.3	Control Box Wiring	15.0	Exploded View & Parts List
7.4	Circuit Board Configuration	16.0	Warranty for Extend-A-Gun RC
7.5	Verify Proper Voltage & Operation		



**PERSONAL RESPONSIBILITY CODE**

The member companies of FEMSA that provide emergency response equipment and services want responders to know and understand the following:

1. Firefighting and Emergency Response are inherently dangerous activities requiring proper training in their hazards and the use of extreme caution at all times.
2. It is your responsibility to read and understand any user's instructions, including purpose and limitations, provided with any piece of equipment you may be called upon to use.
3. It is your responsibility to know that you have been properly trained in Firefighting and /or Emergency Response and in the use, precautions, and care of any equipment you may be called upon to use.
4. It is your responsibility to be in proper physical condition and to maintain the personal skill level required to operate any equipment you may be called upon to use.
5. It is your responsibility to know that your equipment is in operable condition and has been maintained in accordance with the manufacturer's instructions.
6. Failure to follow these guidelines may result in death, burns or other severe injury.



Fire and Emergency Manufactures and Service Association  
P.O. Box 147, Lynnfield, MA 01940 • www.FEMSA.org

### 1.0 MEANING OF SAFETY SIGNAL WORDS

A safety related message is identified by a safety alert symbol and a signal word to indicate the level of risk involved with a particular hazard. Per ANSI standard Z535.4-2007, the definitions of the four signal words are as follows:



**DANGER** indicates a hazardous situation which, if not avoided, will result in death or serious injury.



**WARNING** indicates a hazardous situation which, if not avoided, could result in death or serious injury.



**CAUTION** indicates a potentially hazardous situation which, if not avoided, may result in minor or moderate injury.

## 2.0 SAFETY

**⚠ DANGER**

Do not use AC current to operate the Extend-A-Gun RC. The Extend-A-Gun RC is a 12 or 24 volt DC system **ONLY!** Using the wrong power source could cause electrocution, resulting in death or serious injury.

**⚠ WARNING**

Reaction forces generated by master stream flows are very powerful and capable of causing injury and property damage. The Extend-A-Gun RC must be securely mounted to rigid truck support members. Qualified persons should determine suitable mounting locations

**⚠ WARNING**

Qualified individuals should conduct mounting bracket installation. Inferior welding or poor plate installation could result in serious injury or equipment damage.

**⚠ WARNING**

Keep the upper and lower brackets as far apart as possible to minimize the amount of stress on the upper and lower brackets.

**⚠ WARNING**

The forces acting on the mounting brackets, when the Extend-A-Gun RC is in the extended position, are higher than the forces in a normal deck gun installation. Failure to properly secure the Extend-A-Gun RC, could result in damaged equipment and serious injury.

**⚠ WARNING**

Master stream flows are very powerful and capable of causing injury and property damage. Make sure the monitor is pointing in a safe direction before water to the monitor is turned on. Use care in directing the stream.

**⚠ CAUTION**

Clear all personnel and obstructions away from the Extend-A-Gun RC before lowering. This unit relies on electronic braking and may lower quickly in the event of a failure. Anything caught underneath the monitor, could become crushed, when lowered.

**⚠ CAUTION**

The Extend-A-Gun RC has current limiting capabilities which stops the motor if an obstruction is encountered. The Extend-A-Gun RC must be installed as instructed using the correct controls and electrical boxes. Failure to do so will result in damage to the electric motor and loss of current limiting controls. This may result in injury.

**⚠ CAUTION**

The Extend-A-Gun RC may be used in either the raised or the lowered position, but not in-between. The unit may become damaged if the water is turned on in any position other than fully extended or retracted.

**⚠ CAUTION**

Do not plug or cap the Extend-A-Gun RC or mounted deck gun while it is in the raised position. This will prevent the Extend-A-Gun RC from being lowered to the park position. Damage may occur if the truck drives under a low hanging object, while the Extend-A-Gun RC is extended.

## 3.0 GENERAL INFORMATION

The Extend-A-Gun RC lets you lower your deck mounted master stream device to deck level for storage (or even into a well). On the fire ground, the monitor can be automatically raised to its extended position (12 or 18 extra inches, 30.4 or 45.7 extra cm) with a simple push of a button. This gives greater clearance of other equipment on the apparatus, greater freedom of movement, and keeps firefighters off the top of the trucks, thus providing a safer operating position. The Extend-A-Gun RC offers a full 360 degree monitor rotation in either the raised or lowered position, large waterway, Hardcoat anodized aluminum finish. Built in sensor for connection to "monitor raised" light. Waterproof electric drive, motor control box, and optional panel mount operator station for recessed mounting complete with cables and plugs for connecting TFT RC monitor and RC Extend-A-Gun. Connecting RC Extend-A-Gun motor control box to RC monitor communication link (blue & white wires) allows RC Extend-A-Gun operation from any monitor operator station equipped with AUX1 button or input. Can be specified with new or retrofitted to existing apparatus.

### 3.1 SPECIFICATIONS

MODEL	EXTEND-A-GUN RC3	EXTEND-A-GUN RC4
Waterway Size	3" (76mm)	4" (102mm)
Max Flow	1250 gpm (4800 l/min)	2000 gpm (7600 l/min)
Max Pressure	200 psi (13.8 bar)	
Lifting Capabilities	100 lbs (46kg)	
Lifting Speed	6 sec	
Lowering Speed	12 sec	
Voltage	12 or 24 VDC (auto sense)	
Operating Temperature Range	-30°F to +120°F (-34°C to +49°C)	
Current Draw Lifting	8 amps @ 12 VDC, 4 amps @ 24 VDC	
Current Limit	18 amps @ 12 VDC, 9 amps @ 24 VDC	
Current At Rest	1/4 amp @ 12 VDC, 1/8 amp @ 24 VDC	
Recommended Fuse or Circuit Breaker Size	20 amp @ 12 VDC, 10 amp @ 24 VDC	
Travel	12" (305mm) or 18" (457mm)	

### 3.2 PARTS IDENTIFICATION

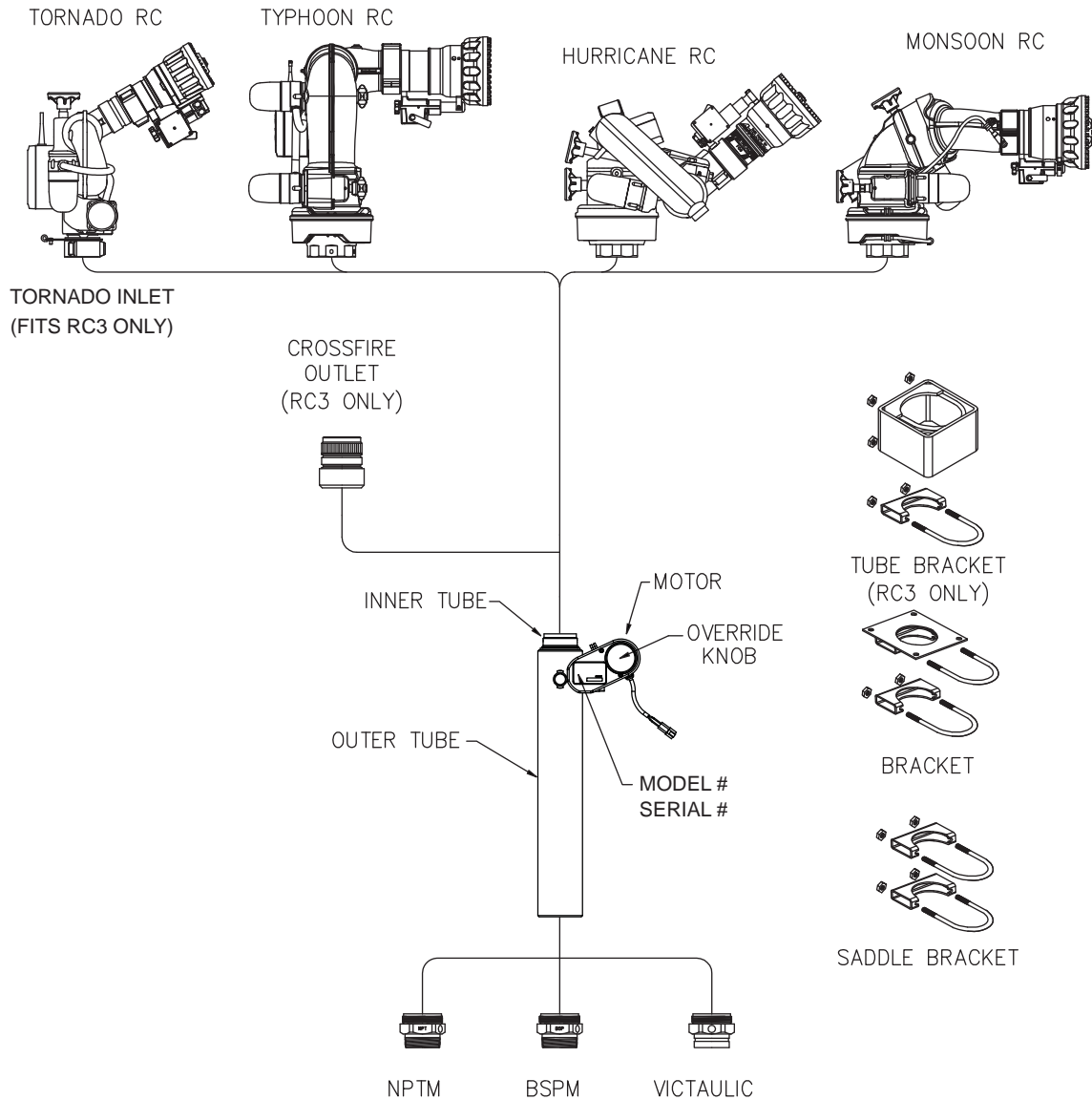

Fig 3.2

### 3.3 DIMENSIONS

## 12" EXTEND-A-GUN RC3 3" Waterway 12" Travel

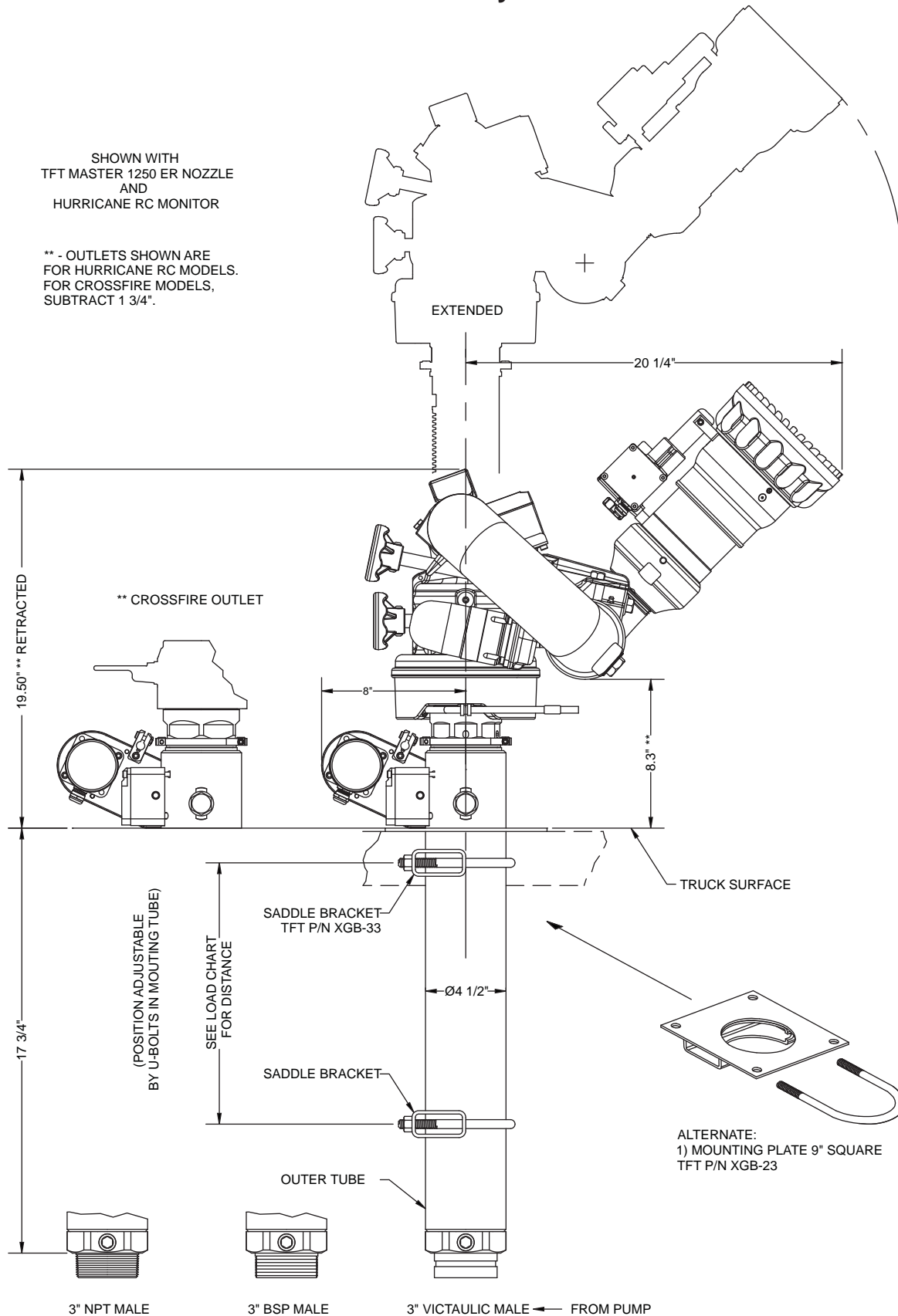

Fig 3.3a

### 3.3 DIMENSIONS

## 18" EXTEND-A-GUN RC3 3" Waterway 18" Travel

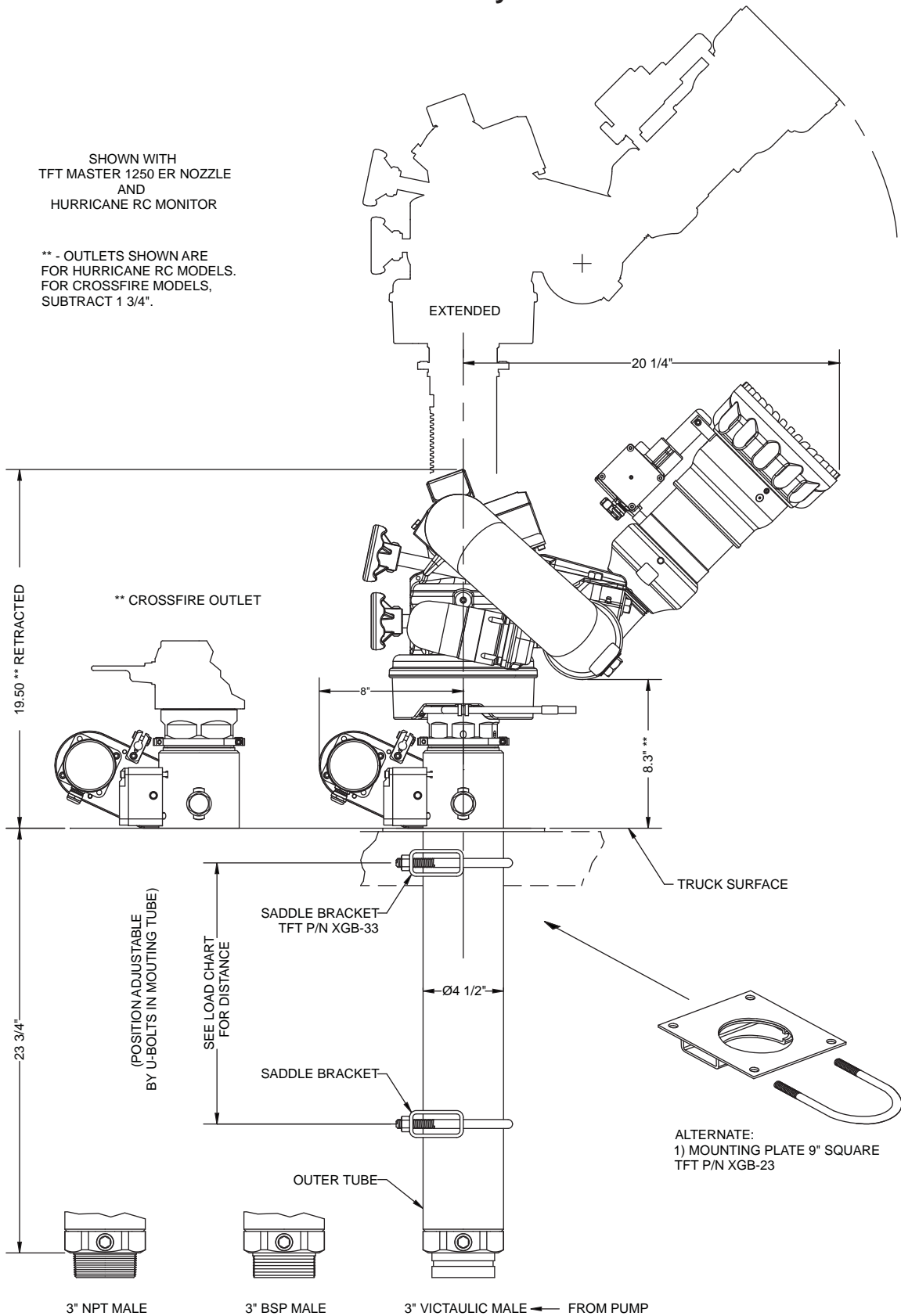

Fig 3.3b

### 3.3 DIMENSIONS

## 18" EXTEND-A-GUN RC4 4" Waterway 18" travel

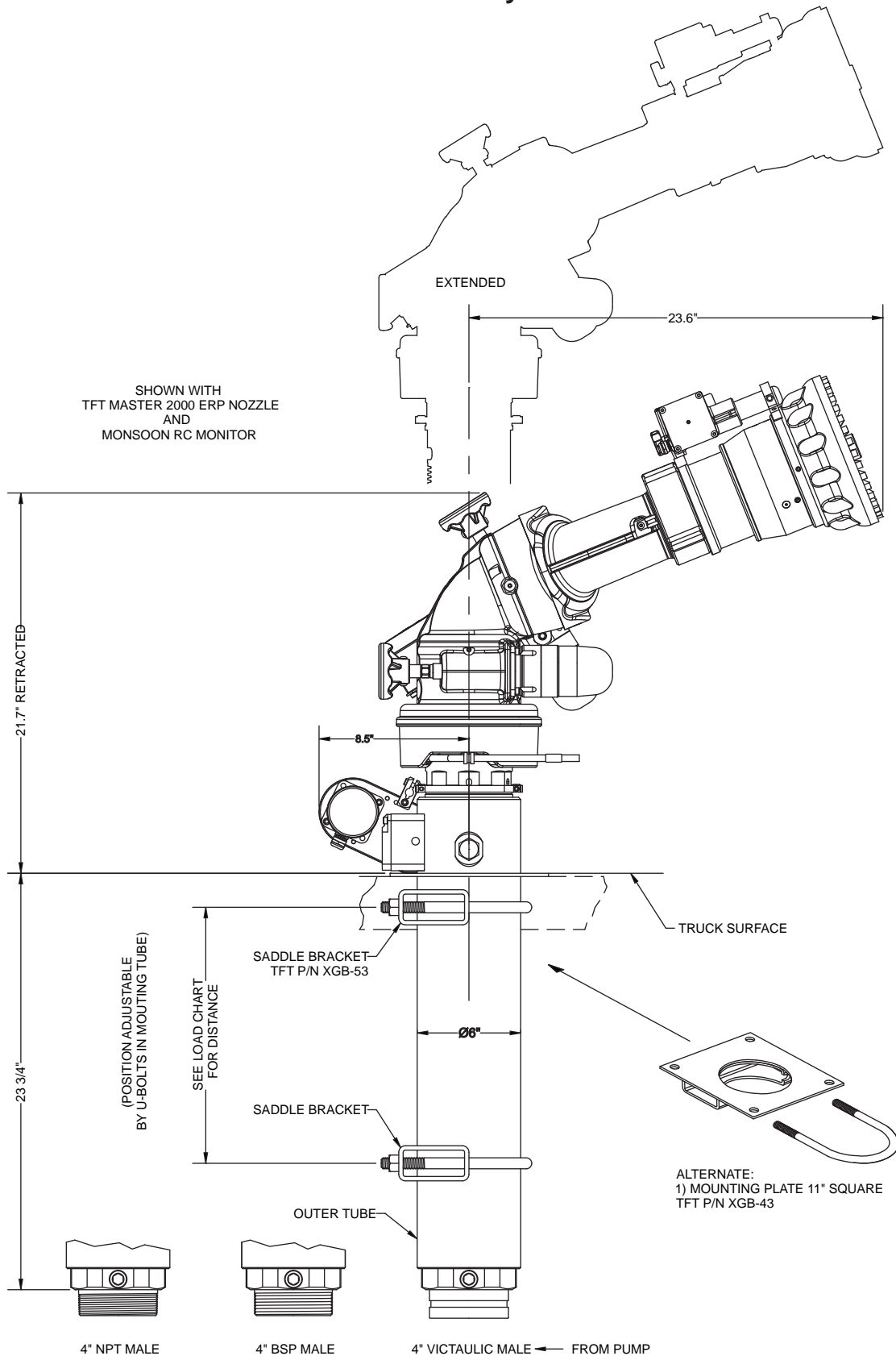

Fig 3.3c

## 4.0 BRACKET SETS

For safe dependable service, the Extend-A-Gun RC MUST be securely mounted. To make the Extend-A-Gun RC as versatile as possible, three mounting bracket kits are offered. Each kit has a different upper bracket. The lower bracket is the same in all three.



**Task Force Tips strongly recommends that Extend-A-Gun RC be installed using the bracket sets, sold by Task Force Tips that are designed for this purpose. For the Extend-A-Gun RC to operate safely and properly, it must be installed in such a way that the brackets can withstand the forces resulting from the nozzle reaction force. The Task Force Tips bracket sets are designed to fit the Extend-A-Gun RC outer tube very closely to prevent distortion of the outer tube and to give it adequate support.**

### 4.1 SELECTION OF STRUCTURAL SUPPORT ON FIRE TRUCKS.

The forces acting on the mounting brackets, when the Extend-A-Gun RC is in the extended position, are higher than the forces in a normal deck gun installation. The loads on the brackets created from nozzle reaction can exceed 3000 lbs when the Extend-A-Gun is fully extended. These loads are transferred directly to the mounting brackets and the structural members they are attached to. It is crucial that the structural members selected, can withstand these forces. Qualified persons should calculate these forces and determine suitable mounting locations and structural members. Failure to properly secure the Extend-A-Gun RC, could result in damaged equipment and serious injury.



**Reaction forces generated by master stream flows are very powerful and capable of causing injury and property damage. The Extend-A-Gun RC must be securely mounted to rigid truck support members. Qualified persons should determine suitable mounting locations.**



**Inferior welding or poor plate installation could result in serious injury or equipment damage. Qualified individuals should conduct mounting bracket installation.**

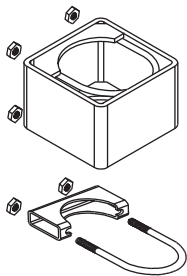

TUBE/SADDLE BRACKET SET  
XGB-13 (Extend-A-Gun RC3)  
N/A (Extend-A-Gun RC4)

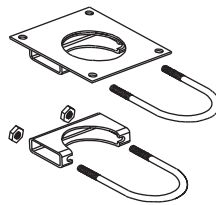

PLATE/SADDLE BRACKET SET  
XGB-23 (Extend-A-Gun RC3)  
XGB-43 (Extend-A-Gun RC4)

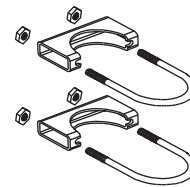

SADDLE/SADDLE BRACKET SET  
XGB-33 (Extend-A-Gun RC3)  
XGB-53 (Extend-A-Gun RC4)

### 4.2 TUBE BRACKET INSTALLATION (Extend-A-Gun RC3 Only)

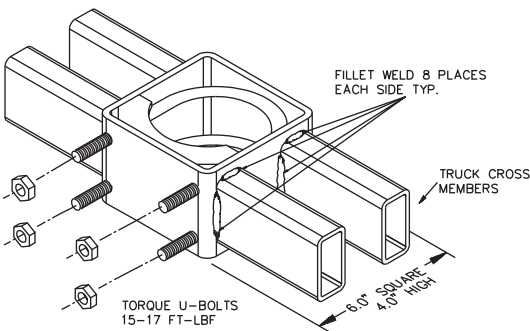

QTY	PART	DESCRIPTION
4	VT37-16FNT	3/8-16 FLANGED HEX NUT
1	XG480	TUBE BRACKET
2	XG475	4-1/2 U-BOLT 3/8 DIA.

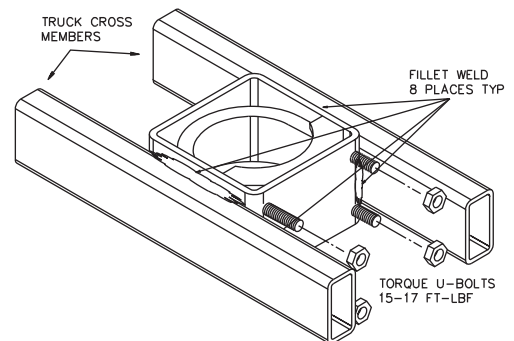

### TUBE BRACKET WELDING

This kit contains a six inch square steel tube with two U-bolts to be used as the upper bracket and a saddle bracket, similar to a heavy duty muffler clamp for the lower bracket. Both brackets must be used. This kit is designed primarily for installation in trucks as they are being built at the factory. The tube bracket may be welded onto the truck tubular framework, as shown on the Tube Bracket Welding Diagram. The lower bracket, as shown in the Saddle Bracket Welding Diagrams, should be welded to an additional support and clamped as low as possible on the bottom of the Extend-A-Gun RC tube. Make sure the welds are capable of withstanding the forces shown on the Side Loads At Mounting Points Diagram. The Extend-A-Gun RC may be installed in the brackets after the truck is painted. Use Loctite, supplied in kit on U-bolt threads, and torque nuts on upper U-bolts to 15-17 ft-lbf, torque nuts on lower U-bolts to 36-40 ft-lbf.



### 4.3 SADDLE BRACKET INSTALLATION

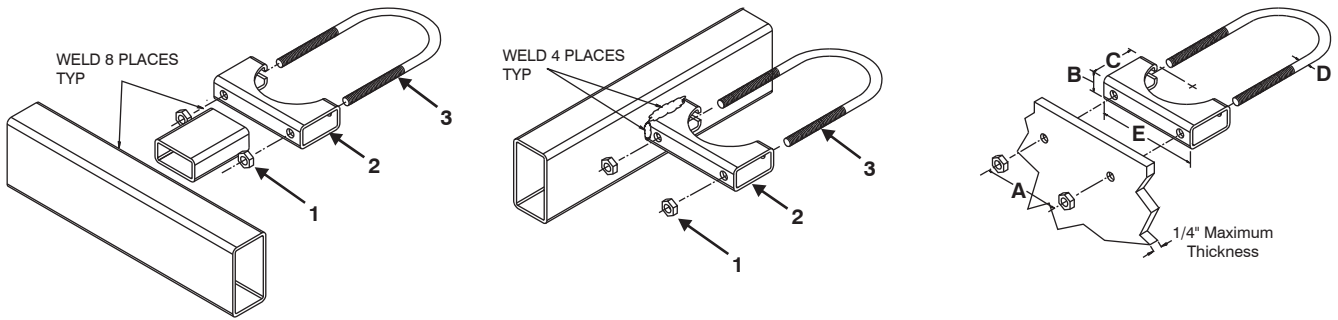

#### SADDLE BRACKET WELDING

This kit contains two steel saddle brackets and U-bolts, and is designed for factory installation on new equipment. Both Brackets must be used and must be welded to truck framework as far apart as possible yet still clamp on the Extend-A-Gun RC tube. The welds must be able to withstand the forces shown on the Side Loads at Mounting Points Diagram (page 8). The Extend-A-Gun RC may be installed in the brackets after the truck is painted. Use Loctite, supplied in kit on U-bolts.

### 4.4 PLATE BRACKET INSTALLATION

This kit may be used in either new or retro-fit installations. The top plate with its bracket may be bolted above or below an existing deck. The lower saddle bracket is installed as previously shown. Both brackets must be used. To minimize the stress on the brackets they should be as far apart as possible when clamped to the Extend-A-Gun RC tube. Please refer to the Side Loads at Mounting Points Diagram and make sure the mounting points can withstand these forces. Use Loctite®, supplied in kit on all threads, torque bolts.

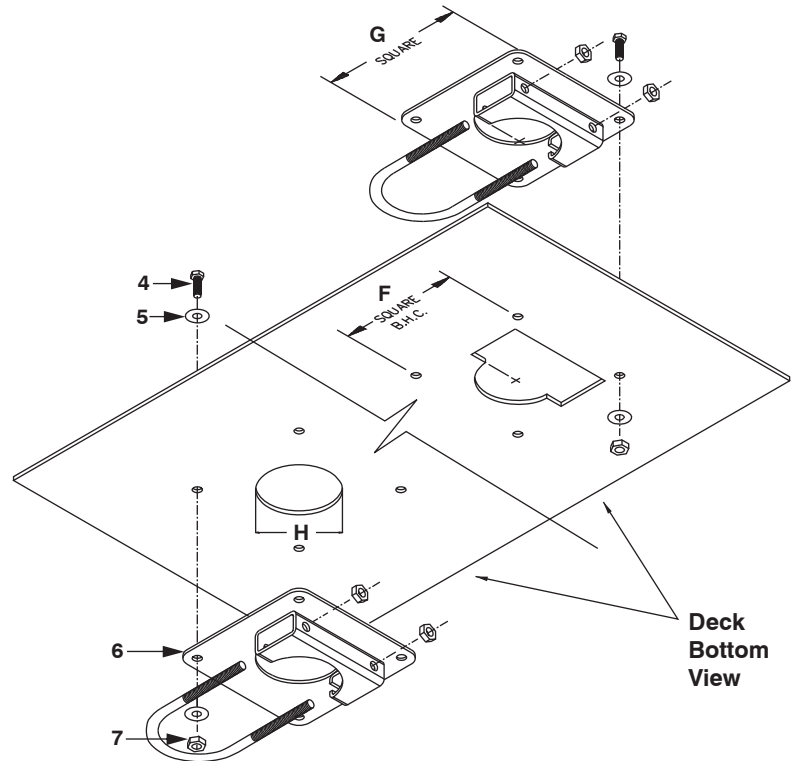

MODEL	EXTEND-A-GUN RC3		EXTEND-A-GUN RC4	
	TORQUE U-BOLTS	30-40 ft-lbs	(49-54 nm)	70-80 ft-lbs
A = Center Distance	5.0"	(127mm)	6.54"	(166mm)
B = Height	1.5"	(38mm)	2.0"	(51mm)
C = Width	3.0"	(76mm)	4.0"	(102mm)
D = U-Bolt Size	1/2-13 UNC		5/8-11 UNC	
E = Length	6.0"	(152mm)	9.0"	(228mm)
F = Square Pattern on Plate	7.5"	(191mm)	9.5"	(241mm)
G = Plate Width & Length	9" x 9"	(288mm x 288mm)	11" x 11"	(279mm x 279mm)
H = Hole Diameter	4-5/8"	(117mm)	6-1/4"	(159mm)
1 = Hex Nut (2 rqd)	VT50-13NT		VT62-11NT	
2 = Saddle Bracket	XG486		XG488	
3 = U-Bolt	XG476		XG477	
4 = Deck Bolt	1/2-13 Hex Bolt		1/2-13 Hex Bolt	
5 = Washer	1/2" I.D.		1/2" I.D.	
6 = Plate Bracket	XG485		XG487	
7 = Deck Nut	1/2-13 Hex Bolt		1/2-13 Hex Bolt	

## 5.0 SIDE LOADS AT MOUNTING POINTS

### 5.1 12" EXTEND-A-GUN RC3

# 12" EXTEND-A-GUN RC3

## WARNING

Before installing the Extend-A-Gun RC you **MUST** determine the forces that will be exerted in the proposed installation by the reaction force of the nozzle.

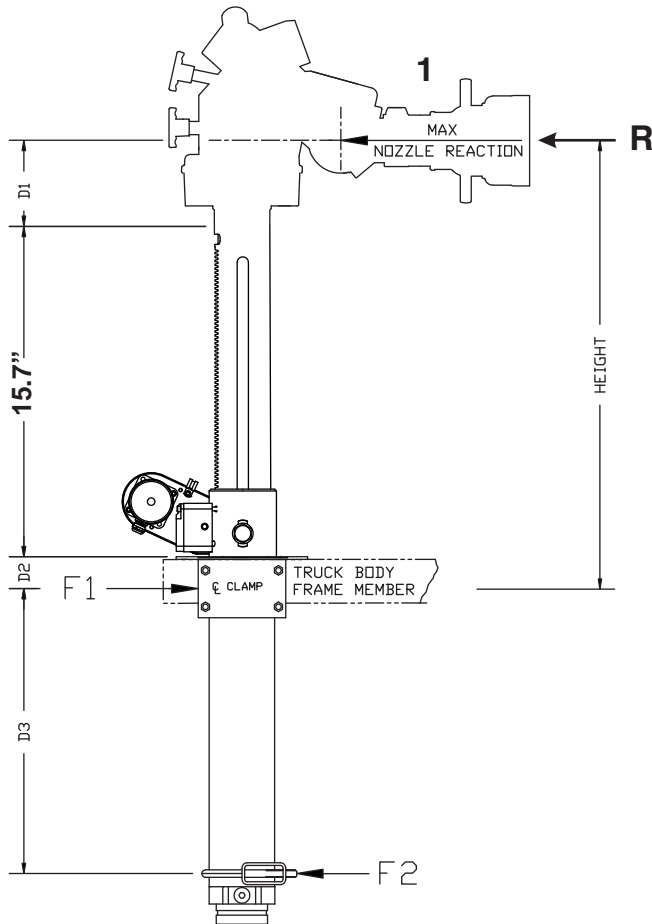

1) Determine the distance, D1, in inches, from the center of the monitor elevation joint to the bottom of the threads in the monitor inlet.

D1 FOR MOST COMMON INSTALLATIONS	
Task Force Tips CROSSFIRE	D1 = 2"
Task Force Tips HURRICANE	D1 = 6"
Task Force Tips MONSOON	D1 = 13"
Task Force Tips TORNADO	D1 = 13"
Task Force Tips TYPHOON	D1 = 19"

D1 =  inches

2) Locate the value of D1, in the charts on page 9. Find the desired HEIGHT from the center of the upper bracket to the center of the stream.

3) Locate D2, the distance from the bottom of the latch casting to the center of the upper mounting bracket, for the chosen HEIGHT. (inches)

D2 =  inches

4) Determine the distance, D3 in inches, from the center of the upper mounting bracket to the center of the lower mounting bracket for the proposed installation. D3 **MUST** be between D3 min and D3 max.

D3 =  inches

5) Calculate forces on Brackets, Add D1 + D2 + D3 + 15.7 =

$$D1 \text{  } + D2 \text{  } + D3 \text{  } + 15.7 = L \text{  } \text{ inches}$$

6) Determine R maximum nozzle reaction from load charts on page 11.

R =  pounds

7) Multiply L x R

$$L \text{  } \times R \text{  } = M \text{  } \text{ inch} \cdot \text{pounds}$$

8) Divide M by D3

$$M \text{  } / D3 \text{  } = F1 \text{  } \text{ pounds}$$

9) Subtract R from F1

$$F1 \text{  } - R \text{  } = F2 \text{  } \text{ pounds}$$

# 12" EXTEND-A-GUN RC3

## 3" Waterway

### R = Maximum Nozzle Reaction 900 lbf

NOTE: F1 MUST be less than 3100 lbf. F2 MUST be less than 2200 lbf.

And the proposed installation MUST be capable of withstanding forces of this magnitude.



**Injury can result from an inadequately supported monitor. The monitor mount must be capable of supporting the nozzle reaction force which can be as high as 900 lbf. (400 kg). Flanges and pipe made from plastic are inadequate for monitor mounting and must not be used.**

D1	D2	HEIGHT	D3 min	D3 max
1	1	18	7	14
	2	19	8	13
	3	20	8	12
	4	21	8	11
	5	22	9	10
	6	23	9	9

D1	D2	HEIGHT	D3 min	D3 max
4	1	21	8	14
	2	22	9	13
	3	23	9	12
	4	24	10	11
	5	25	10	10

D1	D2	HEIGHT	D3 min	D3 max
7	1	24	10	14
	2	25	10	13
	3	26	11	12
	4	27	11	11

D1	D2	HEIGHT	D3 min	D3 max
2	1	19	8	14
	2	20	8	13
	3	21	8	12
	4	22	9	11
	5	23	9	10

D1	D2	HEIGHT	D3 min	D3 max
5	1	22	9	14
	2	23	9	13
	3	24	10	12
	4	25	10	11

D1	D2	HEIGHT	D3 min	D3 max
8	1	25	10	14
	2	26	11	13
	3	27	11	12
	4	28	11	11

D1	D2	HEIGHT	D3 min	D3 max
3	1	20	8	14
	2	21	8	13
	3	22	9	12
	4	23	9	11
	5	24	10	10

D1	D2	HEIGHT	D3 min	D3 max
6	1	23	9	14
	2	24	10	13
	3	25	10	12
	4	26	11	11

D1	D2	HEIGHT	D3 min	D3 max
9	1	26	11	14
	2	27	11	13
	3	28	11	12

D1	D2	HEIGHT	D3 min	D3 max
10	1	27	11	14
	2	28	11	13
	3	29	12	12

### CHART FOR MODEL XGA32 SERIES ONLY

D1	D2	HEIGHT	D3 min	D3 max
13	1	30	12	14
	2	31	13	13

D1	D2	HEIGHT	D3 min	D3 max
19	1	36	14	14

## LOAD CHARTS FOR 12" EXTEND-A-GUN RC3 ONLY

# 18" EXTEND-A-GUN RC4



Before installing the Extend-A-Gun RC you **MUST** determine the forces that will be exerted in the proposed installation by the reaction force of the nozzle.

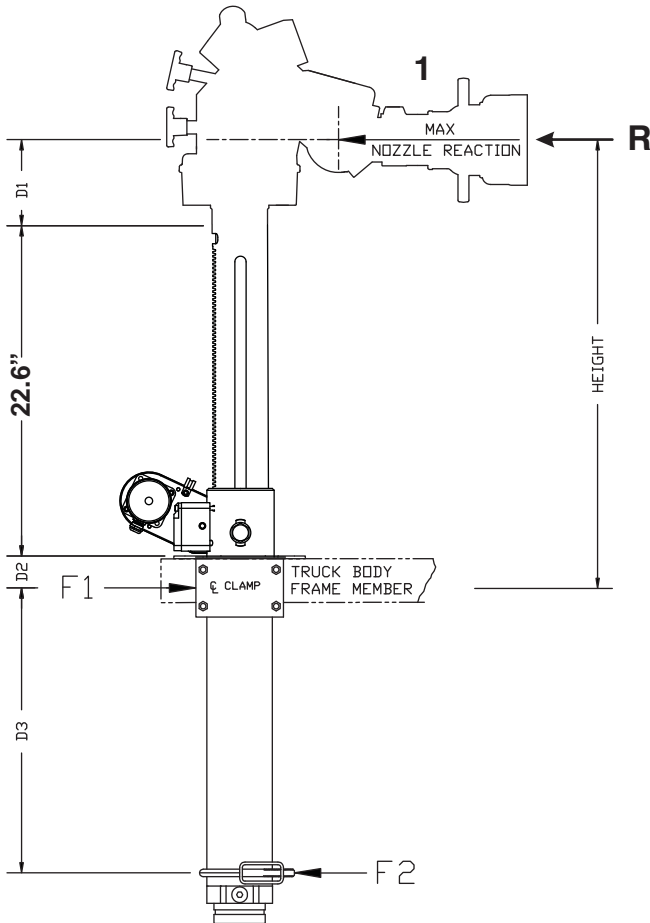

1) Determine the distance, D1, in inches, from the center of the monitor elevation joint to the bottom of the threads in the monitor inlet.

D1 FOR MOST COMMON INSTALLATIONS	
Task Force Tips CROSSFIRE	D1 = 2"
Task Force Tips HURRICANE	D1 = 6"
Task Force Tips MONSOON	D1 = 13"
Task Force Tips TORNADO	D1 = 13"
Task Force Tips TYPHOON	D1 = 19"

D1 =  inches

2) Locate the value of D1, in the charts on page 9. Find the desired HEIGHT from the center of the upper bracket to the center of the stream.

3) Locate D2, the distance from the bottom of the latch casting to the center of the upper mounting bracket, for the chosen HEIGHT. (inches)

D2 =  inches

4) Determine the distance, D3 in inches, from the center of the upper mounting bracket to the center of the lower mounting bracket for the proposed installation. **D3 MUST be between D3 min and D3 max.**

D3 =  inches

5) Calculate forces on Brackets, Add D1 + D2 + D3 + 22.6 =

$$D1 \text{  } + D2 \text{  } + D3 \text{  } + 22.6 = L \text{  } \text{ inches}$$

6) Determine R maximum nozzle reaction from load charts on page 13 and 14.

$$R = \text{} \text{ pounds}$$

7) Multiply L x R

$$L \text{  } \times R \text{  } = M \text{  } \text{ inch} \cdot \text{pounds}$$

8) Divide M by D3

$$M \text{  } / D3 \text{  } = F1 \text{  } \text{ pounds}$$

9) Subtract R from F1

$$F1 \text{  } - R \text{  } = F2 \text{  } \text{ pounds}$$

# 18" EXTEND-A-GUN RC3

## 3" Waterway

**R = Maximum Nozzle Reaction 900 lbf**

**NOTE:** F1 MUST be less than 3100 lbf. F2 MUST be less than 2200 lbf.

And the proposed installation MUST be capable of withstanding forces of this magnitude.

### **⚠ WARNING**

**Injury can result from an inadequately supported monitor. The monitor mount must be capable of supporting the nozzle reaction force which can be as high as 900 lbf. (400 kg). Flanges and pipe made from plastic are inadequate for monitor mounting and must not be used.**

D1	D2	HEIGHT	D3 min	D3 max
1	1	25	11	20
	2	26	11	19
	3	27	11	18
	4	28	12	17
	5	29	12	16
	6	30	13	15
	7	31	13	14
	8	32	13	13

D1	D2	HEIGHT	D3 min	D3 max
5	1	29	12	20
	2	30	13	19
	3	31	13	18
	4	32	13	17
	5	33	14	16
	6	34	14	15

D1	D2	HEIGHT	D3 min	D3 max
9	1	33	14	20
	2	34	14	19
	3	35	15	18
	4	36	15	17
	5	37	15	16

D1	D2	HEIGHT	D3 min	D3 max
2	1	26	11	20
	2	27	11	19
	3	28	12	18
	4	29	12	17
	5	30	13	16
	6	31	13	15
	7	32	13	14

D1	D2	HEIGHT	D3 min	D3 max
6	1	30	13	20
	2	31	13	19
	3	32	13	18
	4	33	14	17
	5	34	14	16
	6	35	15	15

D1	D2	HEIGHT	D3 min	D3 max
10	1	34	14	20
	2	35	15	19
	3	36	15	18
	4	37	15	17
	5	38	16	16

D1	D2	HEIGHT	D3 min	D3 max
3	1	27	11	20
	2	28	12	19
	3	29	13	18
	4	30	13	17
	5	31	13	16
	6	32	14	15
	7	33	14	14

D1	D2	HEIGHT	D3 min	D3 max
7	1	31	13	20
	2	32	13	19
	3	33	14	18
	4	34	14	17
	5	35	15	16
	6	36	15	15

D1	D2	HEIGHT	D3 min	D3 max
11	1	35	15	20
	2	36	15	19
	3	37	15	18
	4	38	16	17
	5	39	16	16

D1	D2	HEIGHT	D3 min	D3 max
4	1	28	12	20
	2	29	12	19
	3	30	13	18
	4	31	13	17
	5	32	13	16
	6	33	14	15
	7	34	14	14

D1	D2	HEIGHT	D3 min	D3 max
8	1	32	13	20
	2	33	14	19
	3	34	14	18
	4	35	15	17
	5	36	15	16
	6	37	15	15

D1	D2	HEIGHT	D3 min	D3 max
12	1	36	15	20
	2	37	15	19
	3	38	16	18
	4	39	17	17

D1	D2	HEIGHT	D3 min	D3 max
13	1	37	15	20
	2	38	16	19
	3	39	16	18
	4	40	17	17

D1	D2	HEIGHT	D3 min	D3 max
19	1	43	17	20
	2	44	18	19

## LOAD CHARTS FOR 18" EXTEND-A-GUN RC3 ONLY

# 18" EXTEND-A-GUN RC4

## 4" Waterway

**R = Maximum Nozzle Reaction 1500 lbf**

**NOTE:** F1 MUST be less than 5000 lbf. F2 MUST be less than 3500 lbf.

And the proposed installation MUST be capable of withstanding forces of this magnitude.

### **⚠ WARNING**

Injury can result from an inadequately supported monitor. The monitor mount must be capable of supporting the nozzle reaction force which can be as high as 1500 lbf. (680 kg). Flanges and pipe made from plastic are inadequate for monitor mounting and must not be used.

D1	D2	HEIGHT	D3 min	D3 max
1	1	25	11	20
	2	26	12	19
	3	27	12	18
	4	28	12	17
	5	29	13	16
	6	30	13	15
	7	31	14	14

D1	D2	HEIGHT	D3 min	D3 max
5	1	29	13	20
	2	30	13	19
	3	31	14	18
	4	32	14	17
	5	33	15	16
	6	34	15	15

D1	D2	HEIGHT	D3 min	D3 max
9	1	33	15	20
	2	34	15	19
	3	35	15	18
	4	36	16	17
	5	37	16	16

D1	D2	HEIGHT	D3 min	D3 max
2	1	26	12	20
	2	27	12	19
	3	28	12	18
	4	29	13	17
	5	30	13	16
	6	31	14	15
	7	32	14	14

D1	D2	HEIGHT	D3 min	D3 max
6	1	30	13	20
	2	31	14	19
	3	32	14	18
	4	33	15	17
	5	34	15	16
	6	35	15	15

D1	D2	HEIGHT	D3 min	D3 max
10	1	34	15	20
	2	35	15	19
	3	36	16	18
	4	37	16	17

D1	D2	HEIGHT	D3 min	D3 max
11	1	35	15	20
	2	36	16	19
	3	37	16	18
	4	38	17	17

D1	D2	HEIGHT	D3 min	D3 max
3	1	27	12	20
	2	28	12	19
	3	29	13	18
	4	30	13	17
	5	31	14	16
	6	32	14	15

D1	D2	HEIGHT	D3 min	D3 max
7	1	31	14	20
	2	32	14	19
	3	33	15	18
	4	34	15	17
	5	35	15	16

D1	D2	HEIGHT	D3 min	D3 max
12	1	36	16	20
	2	37	16	19
	3	38	17	18
	4	39	17	17

D1	D2	HEIGHT	D3 min	D3 max
4	1	27	12	20
	2	28	12	19
	3	29	13	18
	4	30	13	17
	5	31	14	16
	6	32	14	15

D1	D2	HEIGHT	D3 min	D3 max
8	1	32	14	20
	2	33	15	19
	3	34	15	18
	4	35	15	17
	5	36	16	16

D1	D2	HEIGHT	D3 min	D3 max
13	1	37	16	20
	2	38	17	19
	3	39	17	18

D1	D2	HEIGHT	D3 min	D3 max
19	1	43	18	20
	2	44	19	19

## LOAD CHARTS FOR 18" EXTEND-A-GUN RC4 ONLY

## 6.0 MANUAL OVERRIDE

Each Extend-A-Gun RC is equipped with an override knob. In the event of power loss, turn the knob clockwise to raise the tube or counterclockwise to lower it.

### 6.1 REMOVING OVERRIDE KNOB

The manual override knob may be removed if desired. A hex is provided for wrenches with 1/2" (13mm) wrench or socket.

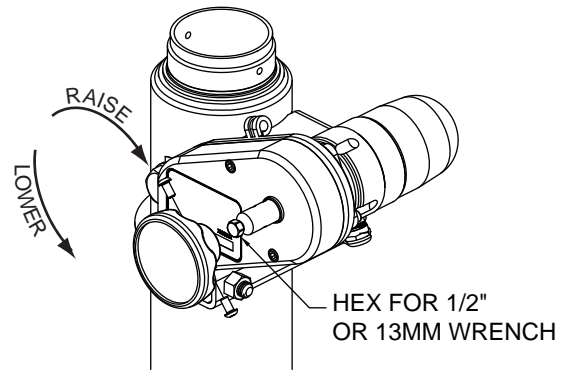

## 7.0 CONTROL BOX INSTALLATION

The Extend-A-Gun RC assembly contains a control box, which houses the electronics that control the electric motor, and an optional panel mount operator station. The panel mount operator station installation is optional and not required if using RC monitor operator stations for control. Most of the wiring has been factory installed so the installation of this control box will include mounting the control box and connecting the wires. A 14-gauge power & communications cable, 10 ft (3m) long, is supplied for connection to the power source and RC monitor communication link. A 14-gauge cable, 12 ft (3m) long, is provided for connection to the RC Extend-A-Gun motor. A 14-gauge cable, 12 ft (3.6m) long, is provided for connection to the RC monitor mounted on top of the RC Extend-A-Gun. If longer length is needed, consult factory. The RC Extend-A-Gun is designed to operate on 12V DC or 24VDC. The RC Extend-A-Gun control box and motor are not rated as ignition proof, explosion proof, or intrinsically safe.



**The electric motor and other components are ignition sources. The electric Extend-A-Gun RC should be operated only in areas where there is adequate ventilation and no hazard of flammable vapor buildup.**



**An inadequate power supply will not drive the electric motor causing a failure to extend the telescoping waterway which will limit the operating range of the monitor. This will result in an increased risk of injury because the effectiveness of the monitor is reduced. Avoid use of thin conductors or long cable. Check installation to insure that a minimum voltage of 10 VDC is present when motor is running.**



**The control box provides electrical braking to keep the Extend-A-Gun from lowering too quickly. Do not operate the Extend-A-Gun RC disconnected from the control box to avoid damage and possible injury. The electronic braking is active even with no electrical power supplied.**

### 7.1 CONTROL BOX MOUNTING

Select proper operator location. Enclosure is designed to be surface mounted and the size is 5 3/4" x 8 3/4" (146 x 222mm). Height of enclosure is 2 1/4" (57mm). Refer to Figure 7.1 for mounting hole dimensions.

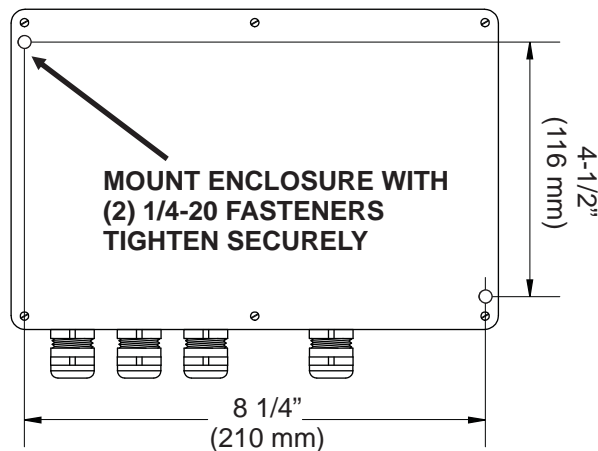

Fig 7.1  
Electrical Enclosure Mounting Hole Dimensions

## 7.2 PANEL MOUNT OPERATOR STATION MOUNTING (OPTIONAL)

Select proper operator location. Operator should be able to view RC Extend-A-Gun operation while operating up/down buttons. Panel space required will be 5-1/4" x 3-5/8" (130mm x 90mm). A depth of 3" (75mm) will be required behind the panel. Refer to Figure 7.2 for dimensions. Be sure to install supplied cable clamp to relieve strain on push button wires.

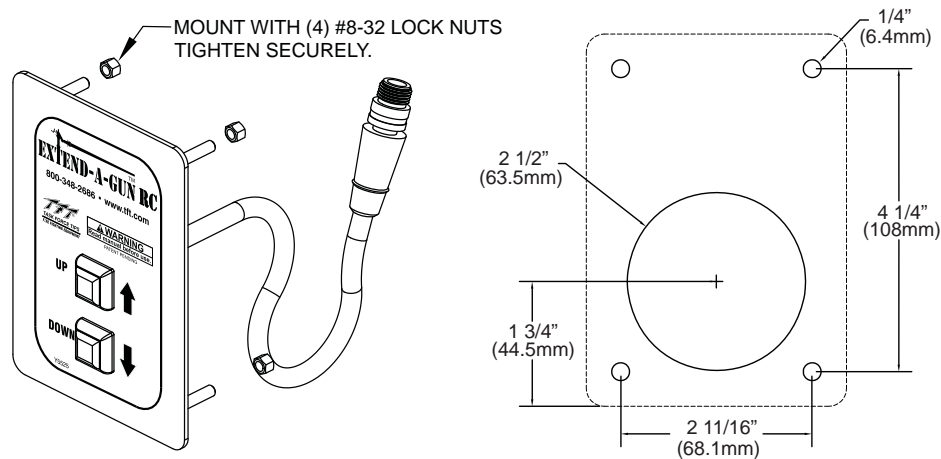

Figure 7.2  
Panel Mount Operator Station Mounting

## 7.3 CONTROL BOX WIRING

The power supply for the RC Extend-A-Gun will need to be connected to a protected circuit from the trucks power distribution center. The waterproof control box is factory sealed. The box should not be opened unless service to the circuit board is needed.

- Good mechanical connections on the wires are absolutely necessary and should be checked periodically.
- Poor electrical connections can cause power loss to the RC Extend-A-Gun and a fire hazard.
- Be careful to route cables in a protected area away from high heat sources.
- Use grommets whenever wires pass through holes to prevent damage due to snags, abrasions, etc.
- Secure cables close to control box with plastic wire tie or cable clamp to relieve stress on the cables.
- Disconnect power before installing or servicing the electrical components.
- Careful selection of wiring is critical to avoid excessive voltage drop.

After mounting control box RC Extend-A-Gun, and RC monitor refer to Figure 7.3 for wiring connections. Refer to RC monitor manuals (LIY-500) section 2 for connecting to communication link.

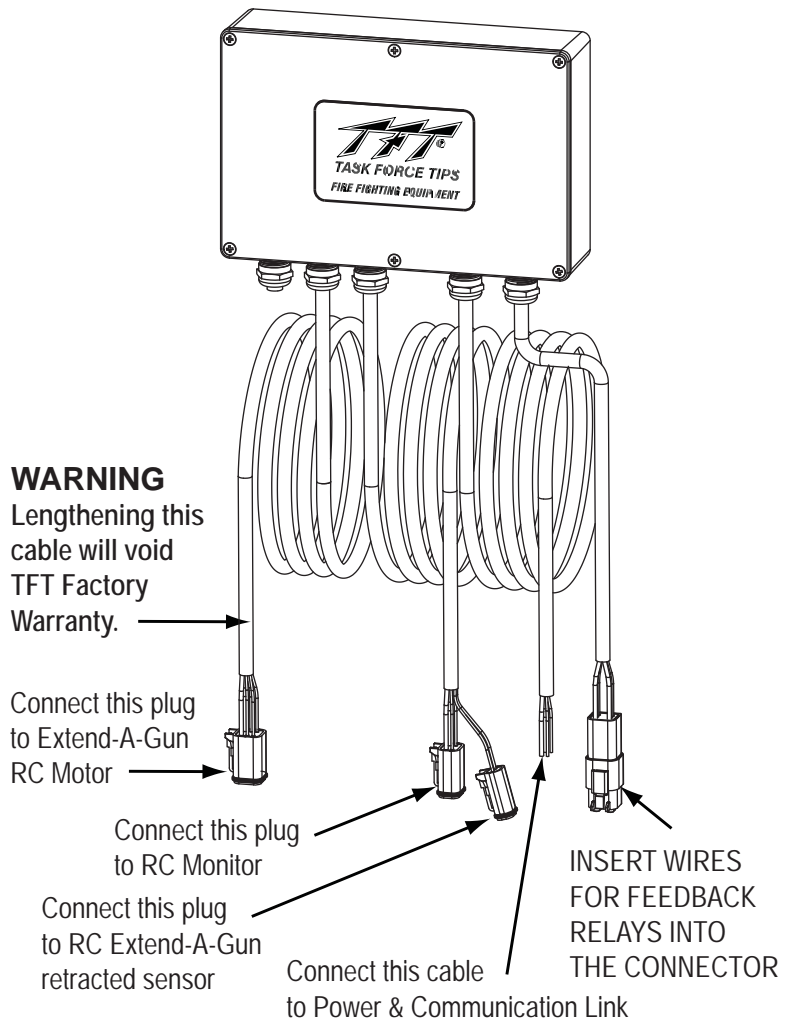

Figure 7.3  
Control Box Wiring



## 7.4 CIRCUIT BOARD CONFIGURATION

The TFT RC Extend-A-Gun circuit board can be configured in a number of different ways using the dip switch located in the upper left hand corner of the circuit board as depicted in Figure 7.4.

- The RC Extend-A-Gun can be configured to operate from either the AUX1 or AUX2 buttons located on any TFT RC monitor operator station. When DIP switch 1 is set to the ON position, the TFT RC Extend-A-Gun will respond to the AUX2 button on the TFT RC monitor operator station as opposed to the default setting of responding to the AUX1 button.
- The circuit board is equipped with a relay that can be configured to be energized either when the RC Extend-A-Gun is raised in the “Extended” position or when it is down in the “At Park” position. Setting DIP switch 2 to the ON position will cause the user configurable relay to energize when the monitor is in the “At Park” position as opposed to the default setting of energizing the relay when the RC Extend-A-Gun is in the “Extended” Position.
- In installations where clearance around the RC Extend-A-Gun is not an issue, setting DIP switch 3 to the ON position will enable the Extend-A-Gun to retract without the monitor being in the “At Park” position. By default the RC Extend-A-Gun will send the “Park” command to TFT RC monitors and wait for the monitor to complete the park sequence before retracting.
- Certain installations involving a TFT RC Extend-A-Gun will involve the monitor being in an extremely confined spaced when the RC Extend-A-Gun is in the retracted position. Setting DIP switch 4 to the ON position will enable the Monitor Disable Interlock feature which disables all TFT RC monitor movement when the RC Extend-A-Gun is retracted as opposed to the default setting that allows TFT RC monitors to move and come out of its park position even though the RC Extend-A-Gun is still retracted.

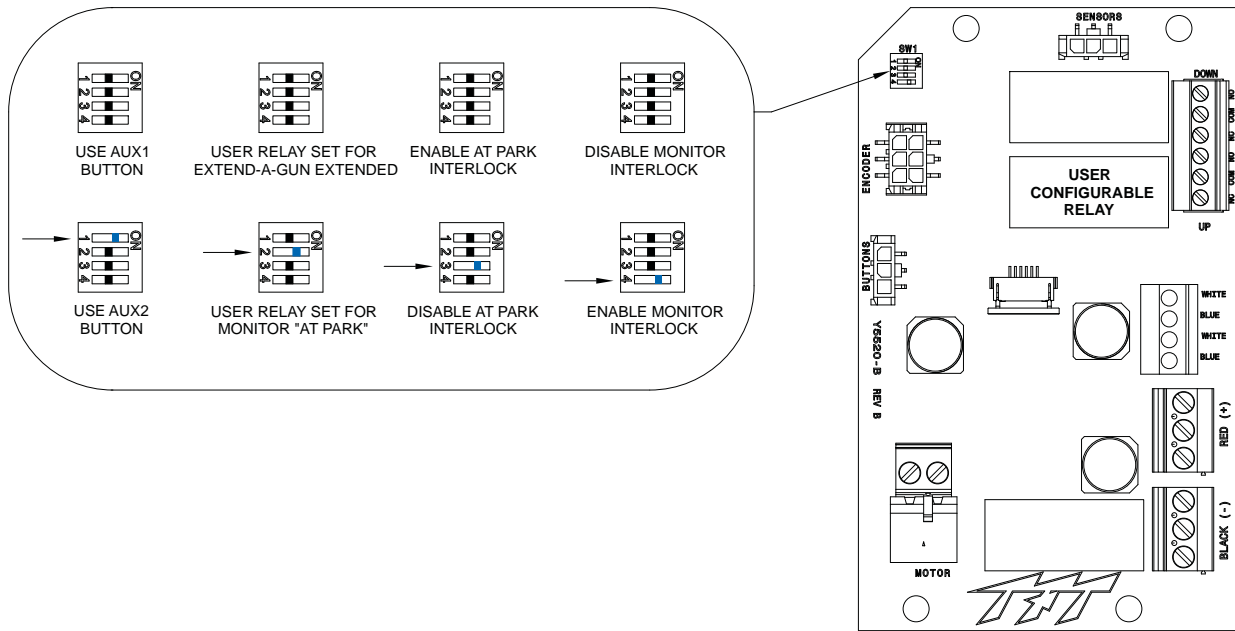

Fig 7.4

## 7.5 VERIFY PROPER VOLTAGE & OPERATION

The TFT Extend-A-Gun has built in circuit protection to guard against a circumstance where the unit’s movement is blocked before reaching its full travel limits. Without this circuitry the motor would stall, overheat, and could be permanently damaged. This circuit works by detecting the increase in electrical current that occurs when the motor stops turning at the end stops or if the travel is blocked by an obstruction.

Once installation and all connections are complete, apply power to control box.

- Press UP button (if available) or AUX1 button from any TFT RC monitor operator station. RC Extend-A-Gun should extend fully.
- Once RC Extend-A-Gun motor stops, attempt to turn the manual override knob CCW to verify that the motor has been disengaged from the circuit. If the motor cannot be turned by hand, this indicates that the motor has not been disengaged from the circuit and electrical power is still applied. If this occurs, the most likely cause is the voltage supplied to the Extend-A-Gun is too low.
- Press DOWN button (if available) or AUX1 button from any TFT RC monitor operator station. RC Extend-A-Gun should retract fully\*\*.

**\*\* If RC Extend-A-Gun is connected to TFT RC monitor, RC monitor must be in “PARK” position before RC Extend-A-Gun will retract. Pressing DOWN (if available) or AUX1 button will automatically command RC monitor to PARK.**

The RC Extend-A-Gun can also be retracted by pressing the P (PARK) button on any TFT RC monitor. The RC monitor will perform the PARK procedure and then the RC Extend-A-Gun will automatically go down.

If a low voltage situation to the RC Extend-A-Gun is suspected, the wiring needs to be checked for proper gauge for the installed length of wire, and for proper termination. Also, ensure that the power source supplying the RC Extend-A-Gun and the grounding is adequate (other electrical loads on a shared circuit with the RC Extend-A-Gun may cause a low-voltage situation).

In addition to motor damage, a further consequence of low voltage could be that the unit will not extend and retract properly or fully.

## 8.0 RETRACTED & EXTENDED RELAY WIRING

The RC Extend-A-Gun contains a magnetic switch that is connected to a relay inside the control box. The magnetic switch and associated relay are energized when the RC Extend-A-Gun is in the retracted position. The control box also contains a relay which can be configured for the installers needs (see section 7.4). For example, to electrically lock out a water valve so water cannot be turned on until the RC Extend-A-Gun is fully extended. When configured for RC Extend-A-Gun "Extended", this relay will be energized when the RC Extend-A-Gun is in the extended position. The installer can select from a normally open (NO) or normally closed (NC) contact for each relay.

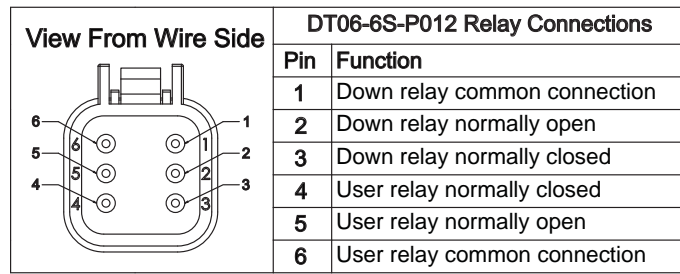

Fig. 8.0

The RC Extend-A-Gun control box includes a cable that is pre-connected to the internal relay for easier access and to prevent the waterproof seal from being damaged from improper re-installation of the lid. The 6-conductor wire and receptacle includes a Deutsch DT06-6S-P012 6-position plug for easy connection. There are easily removed sealing plugs inserted into each wire position to prevent water from entering the connector when there is no wire inserted into the connector position. Use Deutsch 0462-201-16141 solid contacts or 1060-16-0622 stamped and formed pins on 16-20 AWG wire. The connector pin configuration is shown in Figure 8.0 viewed from the wire side of the 6-position plug.

## 8.1 INDICATOR LIGHT MOUNTING & WIRING

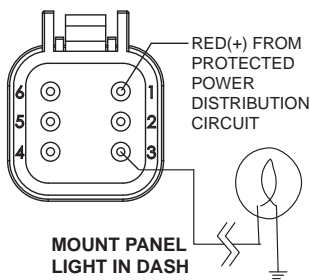

Fig 8.1

Many installations will use the retracted or DOWN relay for the MONITOR EXTENDED warning light or the DOOR OPEN circuit. To install the warning light perform the following:

- 1) Drill a 1/2" diameter hole in the dashboard for the panel light. Leave enough room for a 1-13/16" diameter label around the light or a 2" wide x 1-1/2" high label next to the light.
- 2) Apply one of the two warning labels and push the panel light through the hole in the dash.
- 3) Remove the seal plugs from the Down NC and Down common positions on the 6-position plug connected to the User/Down Relay cable.
- 4) Connect the terminals on the panel light to DOWN NC position on the 6-pin plug and chassis ground, see figure 8.1.
- 5) Connect a wire from the DOWN common position on the 6-pin plug to positive voltage supply.

## 9.0 LABELS

Attach the warning label (XGL020) next to the indicator light or warning label (XGL025) around the indicator light on the truck dashboard. Attach warning label (XGL040) near water valve for deck monitor.



## 10.0 MOUNTING MONITOR

### 10.1 TORNADO, HURRICANE, TYPHOON AND MONSOON

Task Force Tips Tornado, Hurricane, Typhoon and Monsoon® monitor(s) may be mounted directly on the Extend-A-Gun RC. The monitors are attached to the Extend-A-Gun RC by means of a threaded joint with an O-ring seal. Two different methods of rotational locking between the monitor Base and the Extend-A-Gun Inner Tube exist. One method relies on two 1/4-28 Button Head Cap Screws, and the other, newer version, uses a two-piece Clamp that is held together with #10 Cap Screws and Cylindrical nuts. The rotational locking method employed can be identified by the presence or absence of two threaded cross-holes, 180 degrees apart in the threaded portion of the Extend-A-Gun Inner Tube, where the monitor Screws onto the Extend-A-Gun. If 1/4-28 Screws are needed, there will be 1/4-28 threaded cross-holes in the threaded portion of the Extend-A-Gun Inner Tube. If Clamps are needed, there will be no 1/4-28 threaded cross-holes in the threaded portion of the Extend-A-Gun Inner Tube. Once the necessary rotational locking method is determined, install the monitor using one of the following procedures.

#### 1/4-28 BUTTON HEAD CAP SCREW ROTATIONAL LOCK INSTALLATION INSTRUCTIONS (tapped holes):

- 1) Mount so that 180 degree apart threaded cross-holes will give desired direction relative to the "Straight Ahead Reference Mark" when the monitor is installed. See appropriate section in your monitor installation manual.
- 2) Screw monitor onto Extend-A-Gun RC until threaded joint bottoms out.
  - A) Do not use pipe dope or Loctite on the Inlet Base threads. These threads are sealed with an O-ring. The use of thread locking compounds will make removal difficult.

3) Unscrew monitor until a pair of 90 degree apart slots lines up with the 180 degree apart threaded cross-holes in the Extend-A-Gun RC.

A) Orient monitor so that the "Straight Ahead Reference Mark" is facing the desired direction.

B) Slots will line up with threaded cross-holes every 90 degrees of rotation.

C) Monitor may be unscrewed up to one full turn from the bottomed out position.

4) Install 1/4-28 by 1/2 long Button Head Cap Screws and Washers in the two threaded cross- holes. Use Loctite #271 on the threads of the Button Head Cap Screws. Allow Loctite to fully cure before applying water pressure.

### **TWO PIECE CLAMP ROTATIONAL LOCK INSTALLATION INSTRUCTIONS (without tapped holes):**

1) Assemble Clamps and place loosely on Extend-A-Gun.

A) Apply VSA-104 blue Loctite to threads on Cylinder Nut.

B) Loosely install Screws, Washers and Cylinder Nuts on Clamp.

C) Grooves on heads of Cylinder Nuts indicate alignment of threaded holes.

D) Place Clamp assembly over male threads of Extend-A-Gun outlet.

E) Heads of Cylinder Nuts must be on top side of Clamps.

2) Screw monitor onto Extend-A-Gun RC until threaded joint bottoms out.

A) CAUTION: Make sure the Clamps are not tight enough to prevent the monitor Base from bottoming out. The monitor will leak if it does not bottom out in this step.

B) DO NOT USE PIPE DOPE OR LOCTITE ON THE INLET BASE THREADS. These threads are sealed with an O-ring. The use of thread locking compounds will make removal difficult.

3) Unscrew monitor until the "Straight Ahead Reference Mark" is facing the desired direction.

A) Monitor may be unscrewed up to one full turn from the bottomed out position.

B) CAUTION: Monitor will leak if unthreaded more than one full rotation from bottomed-out condition.

4) Rotate the Clamps to the desired orientation.

A) Ensure that Clamp assembly does not interfere with RC monitor Power/Com Cable.

5) Tighten each Screw gradually until both are finger tight with approximately equal spacing between opposite ends of Clamps.

6) Carefully tighten each Screw one additional turn using a 5/32 hex wrench by alternating to the opposite Screw in half turn increments.

A) CAUTION: Over tightening the Screws will damage Screws and Clamps.

## **10.2 CROSSFIRE ON EXTEND-A-GUN RC3**

### **TWO PIECE CLAMP ROTATIONAL LOCK INSTALLATION INSTRUCTIONS (without tapped holes):**

1) Assemble Clamps and place loosely on Extend-A-Gun.

A) Apply VSA-104 blue Loctite to threads on Cylinder Nut.

B) Loosely install Screws, Washers and Cylinder Nuts on Clamp.

C) Grooves on heads of Cylinder Nuts indicate alignment of threaded holes.

D) Place Clamp assembly over male threads of Extend-A-Gun outlet.

E) Heads of Cylinder Nuts must be on top side of Clamps.

2) Screw monitor onto Extend-A-Gun RC until threaded joint bottoms out.

A) CAUTION: Make sure the Clamps are not tight enough to prevent the monitor Base from bottoming out. The monitor will leak if it does not bottom out in this step.

B) DO NOT USE PIPE DOPE OR LOCTITE ON THE INLET BASE THREADS.

These threads are sealed with an O-ring. The use of thread locking compounds will make removal difficult.

3) Unscrew monitor until the "Straight Ahead Reference Mark" is facing the desired direction.

A) Monitor may be unscrewed up to one full turn from the bottomed out position.

B) CAUTION: Monitor will leak if unthreaded more than one full rotation from bottomed-out condition.

4) Rotate the Clamps to the desired orientation.

A) Ensure that Clamp assembly does not interfere with RC monitor Power/Com Cable.

5) Tighten each Screw gradually until both are finger tight with approximately equal spacing between opposite ends of Clamps.

6) Carefully tighten each Screw one additional turn using a 5/32 hex wrench by alternating to the opposite Screw in half turn increments.

A) CAUTION: Over tightening the Screws will damage Screws and Clamps.

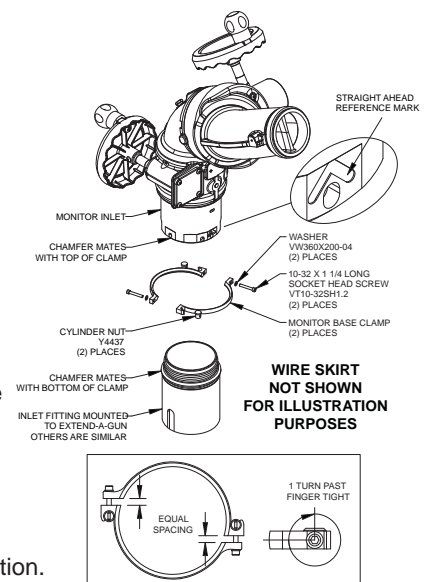

**Injury can occur from an inadequately supported monitor. The mounting must be capable of supporting the nozzle reaction force which can be as high as 1500 lbs.**

## 11.0 USE OF DRAIN

The Extend-A-Gun RC comes with a 3/4" NPT hole in every inlet. This is designed to be used as a drain or plugged and use a drain elsewhere. A drain must be employed to remove excess water from the system. This prevents freezing and allows the Extend-A-Gun RC to be parked.



**The Extend-A-Gun RC may become damaged if it is allowed to freeze while containing water. Always drain after use to avoid damage and possible loss of use.**

## 12.0 OPERATING INSTRUCTIONS



**Master stream flows are very powerful and capable of causing injury and property damage. Make sure the monitor is pointing in a safe direction before water to the monitor is turned on. Use care in directing the stream.**



**Clear all obstructions away from the Extend-A-Gun RC before lowering. Anything caught underneath the monitor, could become crushed, when lowered.**



**The drive train will extend and retract only when there is no water pressure. If the buttons are pushed while under water pressure, the current limiting will engage and not allow the Extend-A-Gun RC to move. This prevents damage to the unit.**



**The Extend-A-Gun RC must be lowered in the park position before the truck is driven or moved. Damage or injury may occur if the truck drives under a low hanging object, while the Extend-A-Gun RC is extended.**



**The Extend-A-Gun RC may be used in either the raised or the lowered position, but not in-between. The unit may become damaged if the water is turned on in any position other than fully extended or retracted.**



**Do not plug or cap the Extend-A-Gun RC or mounted deck gun while it is in the raised position. This will prevent the Extend-A-Gun RC from being lowered in the park position. Damage may occur if the truck drives under a low hanging object, while the Extend-A-Gun RC is extended.**

### 12.1 EXTEND

- 1) Make certain the valve to the monitor is closed.
- 2) Press and release the "UP/AUX1" button on any RC monitor operator station or the panel mount operator station to extend the mechanism. The tube will automatically extend fully, and then stop. Pressing the button while the RC Extend-A-Gun is in motion will cause the motor to switch directions. This system is controlled with current limiting. When the Extend-A-Gun RC is being raised, the unit is provided with maximum allowable current to lift and still protect the mechanism from damage when an obstruction is encountered.
- 3) Position monitor to desired position.
- 4) Open valve to monitor.

### 12.2 RETRACT



**Clear all personnel and obstructions away from the Extend-A-Gun RC before lowering. This unit relies on electronic braking and may lower quickly in the event of a failure. Anything caught underneath the monitor, could become crushed, when lowered.**

- 1) Make certain the valve to the monitor is closed.
- 2) Return the monitor to its park position.
- 3) On systems connected to the RC monitor communication link, at the completion of the PARK pattern, the RC Extend-A-Gun will automatically start to retract.
- 4) To manually retract, press and release the "DOWN/AUX1" button on any RC monitor operator station or the panel mount operator station to retract the mechanism. The tube will automatically retract completely, and then stop. Pressing the button while the RC Extend-A-Gun is in motion will cause the motor to switch directions. This system is controlled with current limiting. When the RC Extend-A-Gun is being lowered, the current is reduced and the unit is slowed down. This provides a safer lowering of the unit and prevents a crushing injury in case someone is under the unit when it is lowered. (Note: Monitor will automatically perform PARK pattern if not "AT PARK" position.)

### 12.3 MANUAL OVERRIDE

Each Extend-A-Gun RC is equipped with an override knob. In the event of power loss, turn the knob clockwise to raise the tube or counterclockwise to lower it.

### 12.4 INDICATOR LIGHT

The Extend-A-Gun RC has a built in switch to control an indicator light on the truck dashboard showing that the Extend-A-Gun RC is in the extended position. This is to help prevent damage that would occur if the deck gun hits a low overhanging object. Do not move the truck with the Extend-A-Gun RC in the extended position.

## 12.5 OPERATION BELOW FREEZING TEMPERATURES

The apparatus that the Extend-A-Gun is mounted to may be stored in sub-freezing conditions. However, the Extend-A-Gun RC is not designed to operate in sub-freezing conditions. If in the rare instance that the Extend-A-Gun becomes inoperable due to a frozen condition, it may still be used in the lowered position.

## 12.6 CONTINUOUS OPERATIONS

The Extend-A-Gun RC is designed to produce a short burst of maximum lifting power. This is provided by a combination of a powerful motor and a high torque gearbox. The motor/gearbox combination means that heat quickly builds up in the motor. As the heat increases, the efficiency decreases, thus reducing power and speed.

## 12.7 CURRENT LIMITING

The Extend-A-Gun RC is designed to produce a short burst of maximum lifting power. The drive train is protected by a current limiting setting. When the Extend-A-Gun RC is being raised, the unit is provided with maximum allowable current to lift and still protect the mechanism from damage when an obstruction is encountered. When the Extend-A-Gun RC is being lowered, the drive is programmed to run at a slower speed and the current limit is reduced.

## 12.8 USE WITH SALT WATER

Use with salt water is permissible provided the Extend-A-Gun is thoroughly cleaned with fresh water after each use. The service life of the Extend-A-Gun may be shortened due to the effects of corrosion and is not covered under warranty.

## 13.0 TROUBLE SHOOTING

SYMPTOM	POSSIBLE CAUSE	REMEDY
Leaks	Debris or damage in seal area	Clean out debris or replace damaged parts
Binding, Erratic operation	Low Voltage (see below)	See Below
Does not raise	Low voltage due to: - wire gage too small - wire length too long - poor connection - inadequate apparatus electrical system  Mechanical Binding - damage to chain drive	Check connections and wiring per section 7.3 Verify voltage is above 8 volts.  Use manual override to verify mechanical operation. Consult Factory
Does not lower	Low voltage due to: - wire gage too small - wire length too long - poor connection - inadequate apparatus electrical system  Mechanical Binding  Monitor not in PARK position. - damage to chain drive	Check connections and wiring per section 7.3 Verify voltage is above 8 volts.  Use manual override to verify mechanical operation.  Perform Monitor PARK operation. Consult Factory

## 14.0 MAINTENANCE AND INSPECTION

The Extend-A-Gun RC requires little maintenance. The Extend-A-Gun RC should be kept clean and free of dirt. All controls should be checked for freedom of movement and proper operation before each use. Any inoperable or damaged parts should be repaired or replaced immediately. Consult factory for recommended service procedure.

- Make sure that the Extend-A-Gun RC operates freely and without binding throughout its range of travel.
- Make sure that there are no leaks when the Extend-A-Gun RC is flowing water.

### 14.1 LUBRICATION

The Extend-A-Gun RC is permanently lubricated on the cup seal. If lubricant has been removed during service, then apply a thin film of White Lithium Grease on seal surfaces.

## 15.0 EXPLODED VIEW AND PARTS LIST

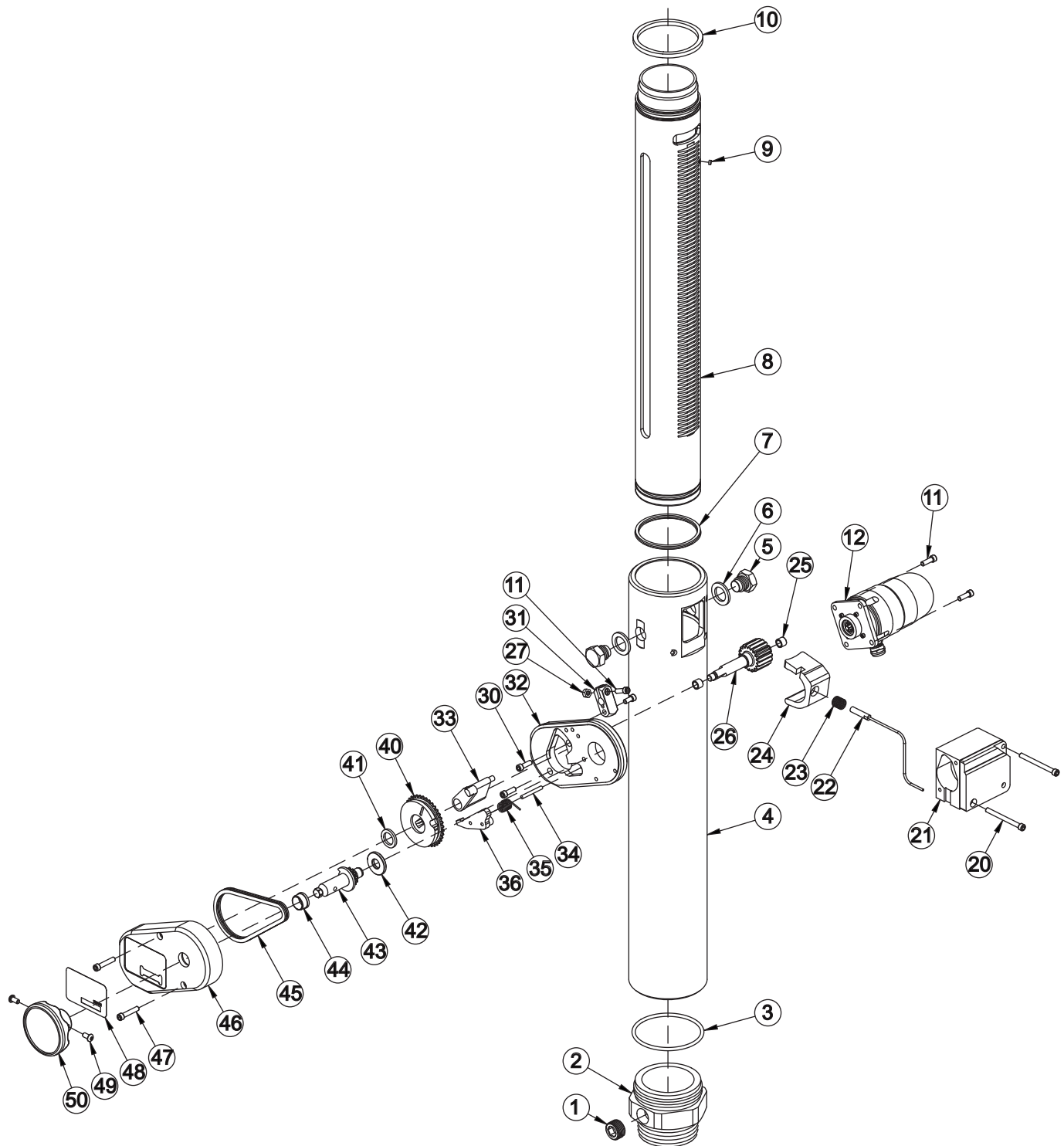

Fig 15

## EXTEND-A-GUN RC3 & RC4

ITEM	PART DESCRIPTION	PART #	QTY
1	3/4"NPTM HEX SOCKET PLUG	VFSP6M	1
2	INLET 3.0"NPT MALE	XG405PL	1
	INLET 3.0"BSP MALE (NOT SHOWN)	XG405BL	
	INLET 3.0"VICTAULIC MALE (NOT SHOWN)	XG405VL	
	MALE INLET 4.0"NPT (NOT SHOWN)	XGE505PP	
	MALE INLET 4.0"BSPM (NOT SHOWN)	XGE505BP	
	MALE INLET 4.0" VICTAULIC (NOT SHOWN)	XGE505VP	
3	O-RING-VO-343 3-3/4 ID 3/16 C/S (RC3)	VO-343	1
	O-RING-VO-351 4-3/4 ID X 3/16 C/S (RC4)	VO-351	
4	3" OUTER TUBE 12" TRAVEL	XGE608	1
	3" OUTER TUBE 18" TRAVEL	XGE606	
	4" OUTER TUBE 18" TRAVEL	XGE601	
5	TRUNNION-STATIONARY	XGE610	2
6	WASHER 304 STAINLESS (RC3 ONLY)	VW1.3X88-125	2
7	CUP SEAL 3/16 X 3.375 X 3.750 (RC3)	XG125	1
	CUP SEAL 4.25 X 4.75 X 1/4 (RC4)	XGE380	
8	3" INNER TUBE 12" TRAVEL	XGE607	1
	3" INNER TUBE 18" TRAVEL	XGE605	
	4" INNER TUBE 18" TRAVEL	XGE600	
9	MAGNET	VM4170	1
10	CUP SEAL 3.50"ID X 4.00"OD X 1/4" (RC3)	XGE613	1
	CUP SEAL 4.50"ID X 5.00"OD X 1/4" (RC4)	XGE614	
11	1/4-20 X 3/4 SOCKET HEAD SCREW	VT25-20SH750	3
12	GEAR MOTOR; EXTEND-A-GUN - SUBASSEMBLY	XGA950	1
20	1/4-20 X 2 3/4 SOCKET HEAD SCREW (RC3)	VT25-20SH2.7	2
	1/4-20 X 2 1/2 SOCKET HEAD SCREW (RC4)	VT25-20SH2.5	
21	MOUNTING BLOCK	XGE620	1
22	REED SWITCH	VM4145	1
23	LATCH SPRING	XGE625	1
24	DOWN LATCH	XGE621	1
25	BUSHING NYLON	X252	2
26	SHAFT WITH GEAR	XGE622	1
27	1/4-20 HEX NUT	VT25-20NT	1
30	1/4-20 X 1/2 SOCKET HEAD SCREW	VT25-20SH500	3
31	3/8 LOOP CLAMP	XGE638	1
32	REDUCER HOUSING	XGE630	1
33	RELEASE LEVER	XGE623	1
34	PIVOT PIN	XX535	1
35	HANDLE TORSION SPRING	A4263	1
36	UP LATCH	XGE633	1
40	SPROCKET 38 TEETH	XGE632	1
41	THIN WASHER	A1530	1
42	BUSHING	XGE637	1
43	DRIVING SPROCKET 12 TEETH	XGE635	1
44	SHORT HEADED BUSHING	XGE634	1
45	58 LINK ROLLER CHAIN	XGE636	1
46	REDUCER COVER	XGE631	1
47	1/4-20 X 1-1/4 SOCKET HEAD SCREW	VT25-20SH1.25	2
48	NAME LABEL: RC3 EXTEND-A-GUN	XGEL630	1
	NAME LABEL: RC4 EXTEND-A-GUN	XGEL640	
49	1/4-20 X 1/2 BUTTON HEAD SCREW	VT25-20BH500	2
50	KNOB	Z245	1

## 16.0 WARRANTY FOR EXTEND-A-GUN RC

Task Force Tips, Inc., 3701 Innovation Way, Valparaiso, IN 46383-9327 USA ("TFT") warrants to the original purchaser of its Extend-A-Gun RC Telescoping Waterway ("equipment"), and to anyone to whom it is transferred, that the equipment shall be free from defects in material and workmanship during the five (5) year period from the date of purchase.

TFT's obligation under this warranty is specifically limited to replacing or repairing the equipment (or its parts) which are shown by TFT's examination to be in a defective condition attributable to TFT. To qualify for this limited warranty, the claimant must return the equipment to TFT, at 3701 Innovation Way, Valparaiso, IN 46383-9327 USA, within a reasonable time after discovery of the defect. TFT will examine the equipment. If TFT determines that there is a defect attributable to it, it will correct the problem within a reasonable time. If the equipment is covered by this limited warranty, TFT will assume the expenses of repair.

If any defect attributable to TFT under this limited warranty cannot be reasonably cured by repair or replacement, TFT may elect to refund the purchase price of the equipment, less reasonable depreciation, in complete discharge of its obligations under this limited warranty. If TFT makes this election, claimant shall return the equipment to TFT free and clear of any liens and encumbrances.

This is a limited warranty. The original purchaser of the equipment, any person to whom it is transferred, and any person who is an intended or unintended beneficiary of the equipment, shall not be entitled to recover from TFT any consequential or incidental damages for injury to person and/or property resulting from any defective equipment manufactured or assembled by TFT. It is agreed and understood that the price stated for the equipment is in part consideration for limiting TFT's liability. Some states do not allow the exclusion or limitation of incidental or consequential damages, so the above may not apply to you.

TFT shall have no obligation under this limited warranty if the equipment is, or has been, misused or neglected (including failure to provide reasonable maintenance) or if there have been accidents to the equipment or if it has been repaired or altered by someone else.

THIS IS A LIMITED EXPRESS WARRANTY ONLY. TFT EXPRESSLY DISCLAIMS WITH RESPECT TO THE EQUIPMENT ALL IMPLIED WARRANTIES OF MERCHANTABILITY AND ALL IMPLIED WARRANTIES OF FITNESS FOR A PARTICULAR PURPOSE. THERE IS NO WARRANTY OF ANY NATURE MADE BY TFT BEYOND THAT STATED IN THE DOCUMENT.

This limited warranty gives you specific legal rights, and you may also have other rights which vary from state to state.