



MANUAL: CROSSFIRE With Safe-Tak 1250 Base

INSTRUCTIONS FOR SAFE OPERATION AND MAINTENANCE

⚠ DANGER

Read instruction manual before use. Operation of this device without understanding the manual and receiving proper training is a misuse of this equipment. A person who has not read and understood all operating and safety instructions, is not qualified to operate the CROSSFIRE portable/deck gun. Call 800-348-2686 with any questions.

⚠ WARNING

Risk of sliding increases at low elevation angles. To reduce risk of injury or death from sliding, do not pull elevation pin stop while on Crossfire Base.

NOTICE

This Instruction Manual is intended to familiarize firefighters and maintenance personnel with the operation, servicing, and safety procedures associated with the portable monitor.

NOTICE

This manual should be kept available to all operating and maintenance personnel.

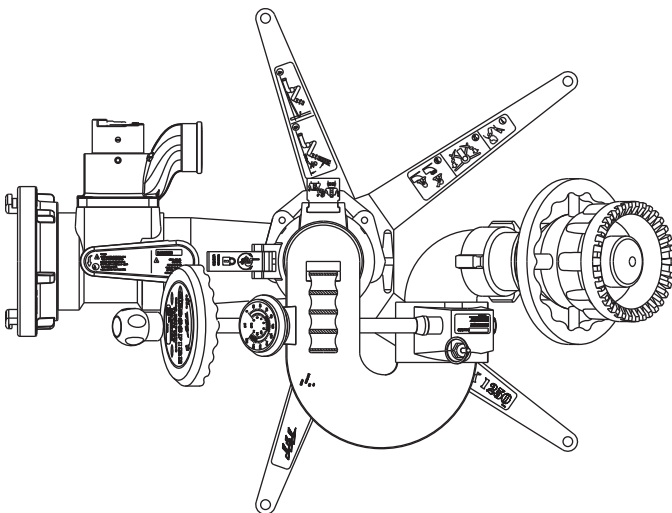
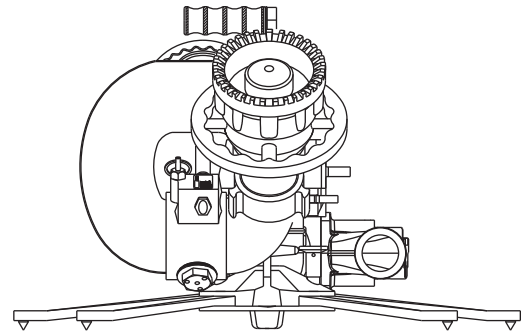
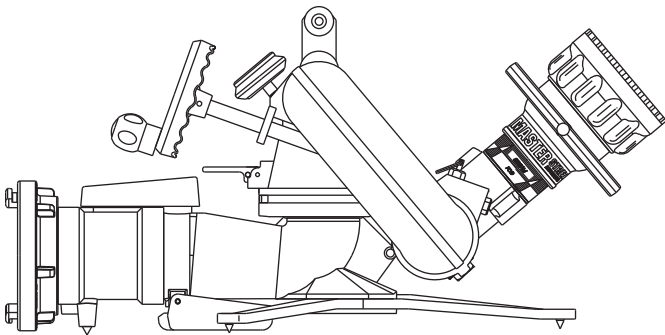

**Maximum recommended
flow is 1250 gpm.
Maximum recommended
inlet pressure is 175 psi.**

⚠ DANGER

PERSONAL RESPONSIBILITY CODE

The member companies of FEMSA that provide emergency response equipment and services want responders to know and understand the following:

1. Firefighting and Emergency Response are inherently dangerous activities requiring proper training in their hazards and the use of extreme caution at all times.
2. It is your responsibility to read and understand any user's instructions, including purpose and limitations, provided with any piece of equipment you may be called upon to use.
3. It is your responsibility to know that you have been properly trained in Firefighting and/or Emergency Response and in the use, precautions, and care of any equipment you may be called upon to use.
4. It is your responsibility to be in proper physical condition and to maintain the personal skill level required to operate any equipment you may be called upon to use.
5. It is your responsibility to know that your equipment is in operable condition and has been maintained in accordance with the manufacturer's instructions.
6. Failure to follow these guidelines may result in death, burns or other severe injury.



Fire and Emergency Manufacturers and Service Association
P.O. Box 147, Lynnfield, MA 01940 • www.FEMSA.org

TASK FORCE TIPS, INC.
MADE IN USA • www.tft.com

3701 Innovation Way, Valparaiso, IN 46383-9327 USA
800-348-2686 • 219-462-6161 • Fax 219-464-7155

Table Of Contents

1.0	MEANING OF SIGNAL WORDS	5.3	PORTABLE BASE LEG SPIKES
2.0	SAFETY	5.4	INSTALLING MONITOR ON BASE
3.0	GENERAL INFORMATION	5.5	PORTABLE BASE ANCHORING
3.1	PART IDENTIFICATION	5.6	PORTABLE BASE SAFETY VALVE
4.0	CROSSFIRE® DEPLOYMENT	5.7	HOSE CONNECTION
4.1	QUICK CONNECT SWIVEL JOINT	5.8	ELEVATION STOP PIN
4.2	INSTALLING MONITOR ON BASE	5.9	ROTATION & ROTATION LOCK
4.3	REMOVING MONITOR TOP FROM BASE	5.10	FLOWS & PRESSURES
4.4	SIDE-TO-SIDE ROTATION & ROTATION LOCK	5.11	REMOVING MONITOR FROM BASE
4.5	ELEVATION CONTROL & STOP PIN	5.12	RETRACTING PORTABLE BASE LEGS
4.6	AUTOMATIC DRAIN	5.13	PORTABLE BASE STORAGE
4.7	TRUCK MOUNT BASE	5.14	PRESSURE RELIEF OPTION
4.8	TRUCK MOUNTING OF THE PORTABLE BASE	5.15	PRESSURE RELIEF VALVE SETTING
4.9	CROSSFIRE® USAGE	6.0	MAINTENANCE
4.10	FLOWS & PRESSURES	6.1	GREASE WORM GEAR
4.10.1	STACKED TIPS	6.2	SAFETY VALVE TESTING
4.10.2	AUTOMATIC MASTER STREAM NOZZLES	6.3	PERFORMANCE TESTING
4.10.3	STREAM STRAIGHTENERS	7.0	SPECIFICATIONS
4.11	TRANSPORTING MONITOR ON TRUCK MOUNT BASE	8.0	DRAWINGS AND PARTS LIST
5.0	SAFE-TAK 1250 BASE	9.0	WARRANTY
5.1	SITE SELECTION	10.0	INSPECTION CHECKLIST
5.2	EXTENDING PORTABLE BASE LEGS		

1.0 MEANING OF SAFETY SIGNAL WORDS

A safety related message is identified by a safety alert symbol and a signal word to indicate the level of risk involved with a particular hazard. Per ANSI standard Z535.6-2006, the definitions of the four signal words are as follows:

 **DANGER**

DANGER indicates a hazardous situation which, if not avoided, will result in death or serious injury.

 **WARNING**

WARNING indicates a hazardous situation which, if not avoided, could result in death or serious injury.

 **CAUTION**

CAUTION indicates a potentially hazardous situation which, if not avoided, may result in minor or moderate injury.

NOTICE

NOTICE is used to address practices not related to personal injury.

2.0 SAFETY

The operation of this monitor, particularly with the portable base can be dangerous.

The following must be observed at all times.

 **DANGER**

Low nozzle elevation angles can cause portable monitors to slide or lift off the ground which can result in injury or death. Do not operate the monitor on the portable base below the elevation safety stop.

 **DANGER**

An out of control monitor can cause injury or death. To reduce risk of instability, do not attempt to move the portable monitor with water flowing.

 **WARNING**

Injury can occur from an inadequately supported monitor. When the monitor is used on a truck the mounting must be capable of supporting 900 lbs of nozzle reaction force. Note: the storage bracket is intended for storage of the monitor only. It is not strong enough to withstand the forces of monitor operation. Flanges and pipe made from plastic are inadequate for monitor mounting and must not be used.

 **WARNING**

A sliding monitor can cause injury. The safety valve on the Safe-Tak 1250 base reduces flow if the monitor leaves the ground. It does nothing to prevent or protect against sliding. Therefore to protect against sliding: Make sure the base legs are locked in position with all leg spikes in contact with the ground. Securely tie the monitor to an object capable of withstanding 900 lbs of force. Use additional tie downs on hard surfaces such as concrete, asphalt, and metal. Avoid lifting the monitor when moving the hoses around it.

 **WARNING**

An unstable monitor can cause injury. If the safety valve trips, shut off the water to the monitor, correct the instability that caused the safety valve to trip, and only then reset the safety valve. Do not attempt to reset the safety valve while flowing.

 **CAUTION**

Master stream flows are very powerful and capable of causing injury and property damage. Make sure the monitor is securely attached to the base and pointing in a safe direction before water to the monitor is turned on. Use care in directing the stream.

3.0 GENERAL INFORMATION

The CROSSFIRE monitor is the most rugged and innovative deck/portable master stream device ever offered to the fire service. Attachment of the CROSSFIRE to the base is quick, easy, positive, and can be visually verified. The release mechanism is locked out by water pressure. The rotation lock is a simple lever which securely holds the CROSSFIRE monitor in position. An automatic drain allows water to drain from the monitor when not in use.

The SAFE-TAK 1250 portable base, available in either single or double inlet configurations, has a revolutionary safety valve which will reduce the flow area through the base by 90% if the SAFE-TAK base should leave the ground for any reason. This safety feature reduces the risk of injury from an out of control master stream device.

3.1 PART IDENTIFICATION

Figures 3.1.1, 3.1.2, & 3.1.3 show the CROSSFIRE monitor, SAFE-TAK 1250 portable base, truck mount adaptor and identifies the various parts and controls.

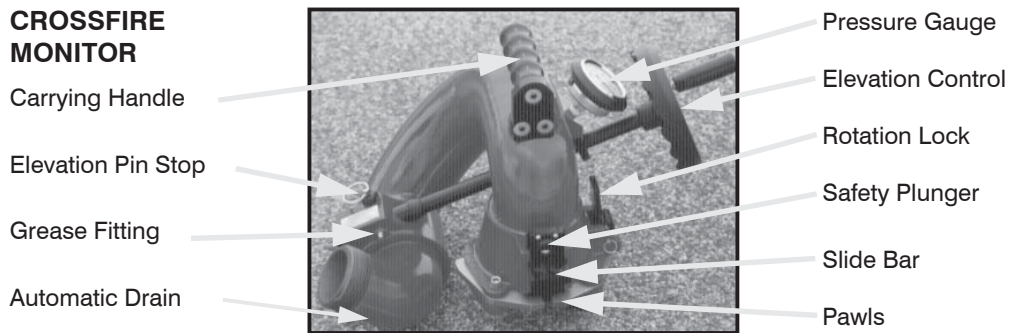

Figure 3.1.1

SAFE-TAK 1250 BASE

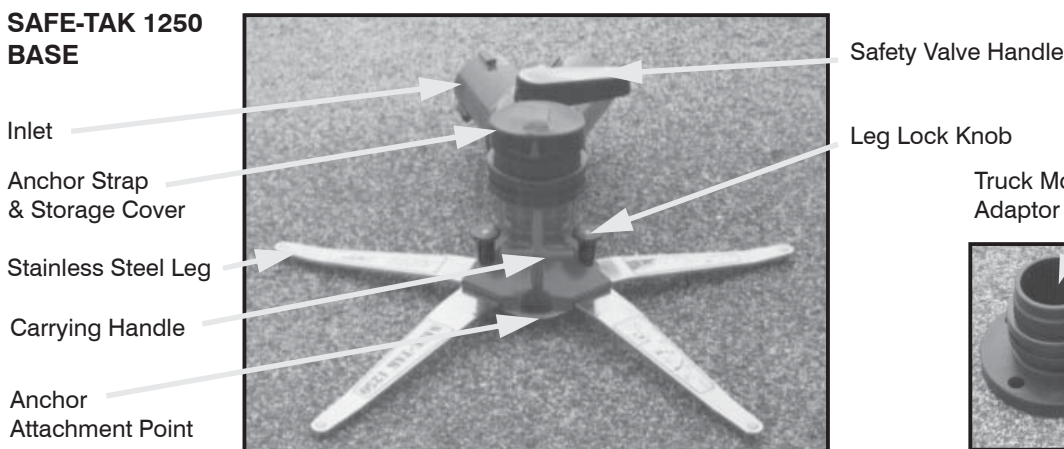

Figure 3.1.2

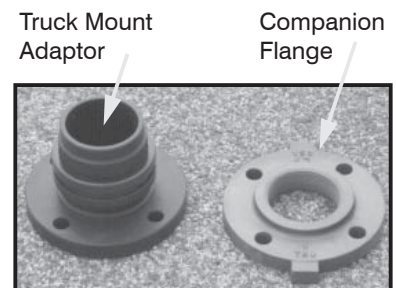

Figure 3.1.3

4.0 CROSSFIRE DEPLOYMENT

The CROSSFIRE monitor can be used on either a truck mounted flange or portable base. Installation on either base makes use of a quick connect swivel joint. The use of each base and the quick connect joint is explained in the following sections.

4.1 QUICK CONNECT SWIVEL JOINT

Two pawls, actuated by the slide bar, engage in the base swivel to make the quick connect joint. A safety plunger engages in the slide bar to prevent accidental unlocking of the slide bar when the monitor is under pressure.

4.2 INSTALLING MONITOR ON BASE

To install the monitor on either the truck mount flange or portable base: Refer to figures 4.2.1, 4.2.2, & 4.2.3.

- Turn elevation handwheel to make sure the elevation of the nozzle is above the 35° safety stop. Verify that the elevation stop pin is down and engaged.
- Make sure the slide bar is in the up position.
- Hold the monitor by the top carrying handle, position monitor over base and slide straight down.
- Push the slide bar down and watch the pawls engage the groove in the base and the safety plunger engage in the hole in the slide bar.

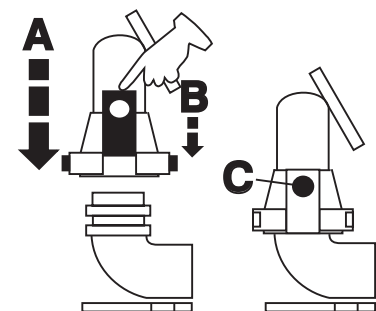
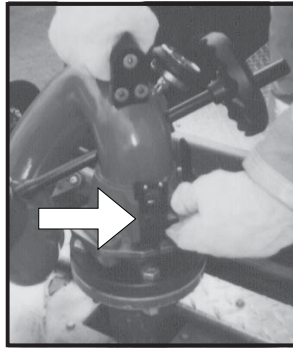

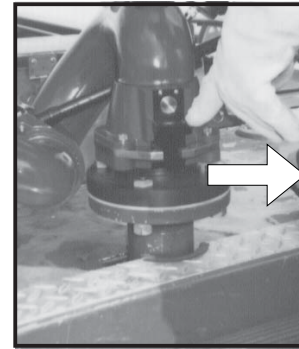

Figure 4.2.1



Slide bar up, safety plunger is not engaged.

Figure 4.2.2



Slide bar locked, safety plunger is engaged.

Figure 4.2.3

4.3 REMOVING MONITOR TOP FROM BASE

To remove the monitor from its base:

- Stop all water flow.
- Depress the safety plunger and lift the slide bar which will disengage the spring loaded pawls from the groove in the base.
- Lift the monitor straight up off the base by the handle on top of the monitor.

4.4 SIDE-TO-SIDE ROTATION AND ROTATION LOCK

Side-to-side rotation is accomplished by rotating the monitor on its base. The rotational position can be locked by moving the rotation lock lever to its down position as shown in Figures 4.4.1 & 4.4.2. Before the monitor is removed from the base, the rotation lock should be manually disengaged. A small spring holds the rotational lock in the unlocked position. When not rotating the monitor on the base, keep the rotation lock locked.

WARNING

A sliding monitor can cause injury. When used on a portable base, keep the horizontal angle between the water stream and the anchor strap as small as possible. At large angles the base can slide in an arc around the anchor point.



Figure 4.4.1
Unlocked



Figure 4.4.2
Locked

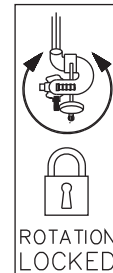

4.5 ELEVATION CONTROL AND STOP PIN

The handwheel controls nozzle elevation (Figure 4.5.1). Clockwise rotation of the wheel will raise the nozzle and counter-clockwise rotation of the wheel will lower the nozzle. A spring loaded stop pin limits the nozzle elevation to 35° with respect to the base.



Figure 4.5.1
Elevation control

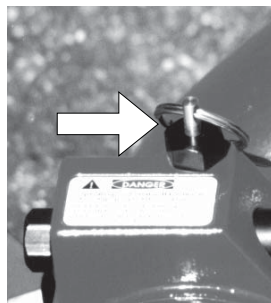

Figure 4.5.2
Elevation stop pin out

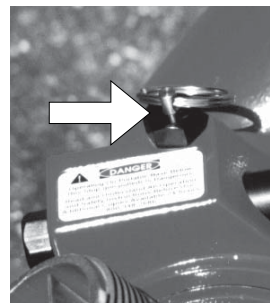

Figure 4.5.3
Elevation stop pin in



DANGER

Operating on a portable base below this safety stop is DANGEROUS. Do not operate on portable base below safety stop. Injury or death can occur if the monitor and base slides or lifts off the ground.

When mounted on a truck base, the nozzle may be lowered below the 35° safety stop by pulling out the stop pin and rotating the handwheel below the 35° stop. When the nozzle is raised back above 35°, the spring loaded stop pin will snap back into position automatically limiting the elevation of the nozzle with respect to the base to 35°.

4.6 AUTOMATIC DRAIN

An automatic drain empties water from a low point in the monitor piping to prevent freezing and help empty hose lines. The valve is designed to close automatically when pressure in the monitor exceeds approximately 5 psi and open again when the pressure drops to that point. When the automatic drain is not desirable it may be disabled. To disable the drain valve refer to the exploded view on page 11 and follow the steps below:

- 1) Unscrew the drain assembly (40, 41, 42, & 43) and remove the screw and washer (42 & 43)
- 2) Flip over the rubber drain valve (41) so that the raised edge is against the face of the housing (40).
- 3) Reassemble.

4.7 TRUCK MOUNT BASE

The CROSSFIRE® monitor may be used from a truck by using a truck mount adapter. The truck mount adapter can be bolted to a three inch riser pipe with a three inch 150 lb. ASA companion flange and gasket using four 5/8" bolts. It can also be screwed directly on a 3" NPT thread. Use of pipe thread sealant is recommended. The riser must be supported to safely withstand a nozzle reaction force of up to 900 lbs (1250 GPM at 175 PSI). Make sure that no interference exists between the monitor and other deck mounted equipment in any direction.

A drain valve should be provided in the riser pipe which supplies the monitor. The riser should be drained immediately after each use during cold weather to prevent freezing and possible damage. The monitor has an automatic drain. If this drain has been disabled (see section 3.6), the monitor must be drained by lowering the nozzle below horizontal. Installation instructions are supplied with the truck mount base.

4.8 TRUCK MOUNTING OF THE PORTABLE BASE

In some cases a user may not have a riser directly off of the pump that can be used for mounting the monitor. In this case it may be desirable to supply the monitor with hose lines connected to the side discharge of the pumper. In these circumstances it is recommended that the user purchase a Deck Mount Plate, TFT part XF400-KIT, from the manufacturer. Please call 1-800-348-2686 for further information and advice concerning mounting alternatives. Installation instructions are shipped with this accessory. The storage bracket, TFT part XF-B, for the base unit IS NOT STRONG ENOUGH to withstand the forces encountered with an operating monitor and is not intended for this purpose.

4.9 CROSSFIRE® USAGE

Because of the arched trajectory of a fire stream, it is recommended that a spotter be used to accurately direct the stream from the monitor. Master streams flows are powerful and capable of injury and damage to property. Use great care in directing the stream.

4.10 FLOWS & PRESSURES

The CROSSFIRE® monitor and SAFE-TAK 1250 portable base are designed for maximum flows of 1250 gpm (5000 l/min) and a maximum pressure of 175 psi (12 bar). Do not exceed these limits. Certain nozzle sizes can exceed these limits.

4.10.1 STACKED TIPS

NOZZLE DIAMETER	NOZZLE PRESSURE									
	50 PSI		80 PSI		100 PSI		150 PSI		175 PSI	
	FLOW (GPM)	REACTION (LBS)	FLOW (GPM)	REACTION (LBS)	FLOW (GPM)	REACTION (LBS)	FLOW (GPM)	REACTION (LBS)	FLOW (GPM)	REACTION (LBS)
1-3/8"	397	148	500	240	560	300	680	440	730	520
1-1/2"	473	177	600	280	660	350	810	520	870	620
1-3/4"	643	240	810	380	910	480	1100	712	1190	840
2"	840	314	1060	500	1190	630	—	—	—	—

4.10.2 AUTOMATIC MASTER STREAM NOZZLES

Automatic nozzles maintain a constant pressure by adjusting their opening to match the available flow. Consult the nozzle manufacturer for maximum flow and pressure ratings. In all cases, do not exceed 1250 gpm (5000 l/min) or 175 psi (12 bar).

4.10.3 STREAM STRAIGHTENERS

Stream quality, especially with smooth bore nozzles, is generally improved with a stream straightener because the water must make many bends passing through a monitor.

4.11 TRANSPORTING MONITOR ON TRUCK MOUNT BASE

If the monitor is to be transported on a truck mount base, the horizontal lock should be kept locked to keep the monitor from spinning on its base. The rotational position can be locked by moving the rotation lock lever to its down position. The nozzle may be supported by a bracket or pointed straight up.

5.0 SAFE-TAK 1250 BASE

The portable base allows the monitor to be positioned in places that are not accessible with a fire truck. As an added measure of safety, the SAFE-TAK 1250 portable base has a safety valve. The function of the safety valve is to quickly reduce flow should the monitor, and portable base, ever leave the ground for any reason. After the water supply is shut down and the cause of the instability corrected the valve may be reset and water flow resumed. The legs are made of spring steel and will flex when in use to compensate for small ground irregularities. Do not reset the safety valve without first shutting off the water flow.

5.1 SITE SELECTION

Safe operation of the monitor on the portable base begins with site selection. The site should be a safe distance from the fire yet within reach of the nozzle stream. Select a flat even surface within 8 feet of a sturdy stationary object that can be used as an attachment point for the anchor strap. Set up the portable base with the anchor point between the portable base and desired target of the nozzle stream.

On ground, such as sand, mud, or gravel, wash out under the paddle may cause unwanted tripping of the safety valve on the SAFE-TAK 1250® portable base. In such case, a thin flat object, such as a clipboard, may be placed under the paddle. Object under paddle must not keep any leg spike from contacting ground.

5.2 EXTENDING PORTABLE BASE LEGS

The portable base legs are extended by following these steps:

(Refer to figures 4.2.1, 4.2.2, & 4.2.3)

- Hold the base carrying handle with one hand and grasp the end of one of the longer legs with the other hand. Pull this leg away from the base forward in an arc, until the locking pin engages. The locking pin is spring loaded and automatically engages when the legs are in the correct position. Watch the leg lock knob drop down, even with the lower band on the base, indicated by an arrow.
- Repeat procedure (a) to extend other set of legs.
- Set portable base on even ground with all leg spikes in contact with the ground.

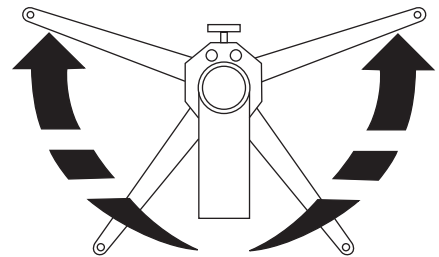

Figure 4.2.1
Hold base carrying handle and grasp end of longer leg



Figure 4.2.2
One set of legs opened and locked in position



Figure 4.2.3
Both sets of legs opened and locked in position

Lift off the storage cap and remove the anchor strap from inside the base, figure 4.2.4. Keep the anchor strap near the monitor as it will be used to anchor monitor before use.

5.3 PORTABLE BASE LEG SPIKES

The SAFE-TAK Base has 5 or 6 tungsten carbide tipped spikes on the legs and base to resist sliding by digging into the surface the base is sitting on. The amount of sideways force these spikes can withstand depends upon several factors, particularly, the amount of downward and sideways force that is on the base and the hardness and texture of the surface the spikes are in contact with. At low elevation angles it is difficult for these spikes to resist sliding. This is why the portable base must be well anchored. These spikes are essential to safe operation of the monitor base and must be in contact with the ground at all times. Do not operate without first securing the monitor with safety lines to prevent sliding. Set the monitor on an even surface so that all the spikes contact the ground. See section 5.0 for spike inspection procedures.



Figure 4.2.4

5.4 INSTALLING MONITOR ON BASE

To install the monitor on either the truck mount flange or portable base: (Refer to figures 4.4.1, 4.4.2, & 4.4.3)

- Turn elevation handwheel to make sure the elevation of the nozzle is above the 35° safety stop. Verify that the elevation stop pin is down and engaged.
- Make sure the slide bar is in the up position.
- Hold the monitor by the top carrying handle, position monitor over base and slide straight down.
- Push the slide bar down and watch the pawls engage the groove in the base and the safety plunger engage in the hole in the slide bar.

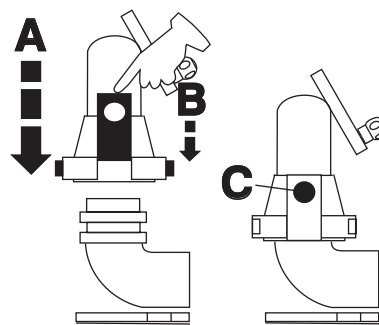

Figure 5.4.1
Hold monitor by the top carrying handle, position monitor over base and slide straight down

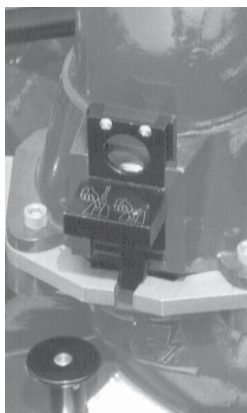

Figure 5.4.2
Slide bar up, safety plunger is not engaged



Figure 5.4.3
Slide bar locked, safety plunger is engaged

5.5 PORTABLE BASE ANCHORING

Whenever the monitor is operated on the portable base, the base must be anchored to a substantial immovable object. An attachment point is provided on the front of the base for this purpose. A strap, with a minimum breaking strength of 3000 lbs of force, is supplied with the portable base. A loop on the end of the strap may be placed over the anchor point or the strap may be wrapped around an object, such as a tree, and the snap end of the strap passed through the loop and pulled tight. Keep the entire length of the strap as close to the ground as possible. Snap the hook into the hole in the front of the portable base below the carrying handle. The length of the strap may be adjusted by the sliding the buckle on the strap. If the strap is too short to reach a suitable anchor, it may be extended with strong rope or chain. Keep the distance between the base and anchor point as short as possible.

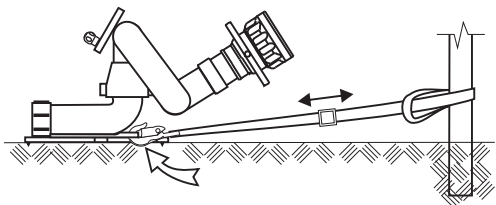

⚠️ WARNING

A sliding monitor can cause injury. Remove all slack between the anchor and base before flowing water.

At low nozzle elevation angles the base may also require additional anchoring. The ability of a single anchor to stop sliding is a function of the horizontal angle between the strap and water stream. When the stream is in line with the anchor any sliding will be arrested by the anchor. As the horizontal angle increases between the anchor strap and the stream, the base can begin to slide in an arc around the anchor point. In this situation multiple anchor points may be required.

The strap should be stored inside the monitor base when not in use. The black rubber cap on the strap will hold the strap in the base and protect the sealing surface of the quick connect swivel joint.

5.6 PORTABLE BASE SAFETY VALVE

⚠️ DANGER

Disconnecting, overriding or tampering with this safety device may result in personal injury.



Figure 4.6.1

Safety valve closed flow restricted



Figure 4.6.2

Safety valve opened full flow achieved

PATENT # 5,593,092

TO RESET:

- 1) MANUALLY REDUCE OR REMOVE THE FLOW OF WATER TO THE MONITOR.
- 2) CORRECT CAUSE OF TRIPPED VALVE.
- 3) ROTATE LEVER IN DIRECTION OF ARROW UNTIL IT LOCKS IN PLACE.
- 4) SLOWLY REOPEN FLOW TO MONITOR.

⚠ DANGER

Disconnecting, Overriding, or Tampering With This Safety Device May Result In Personal Injury.

XL090

The portable base safety valve reduces the flow area through the monitor by 90%, should the base lose contact with the ground for any reason. In the reduced flow condition, the nozzle reaction force is less and reduces the risk of injury.

While the safety valve reduces flow to the monitor, the remaining flow is still capable of causing damage and/or injury. Exercise caution around monitor when valve is tripped or being reset. Always be sure to anchor monitor (See section 4.5).

The safety valve is spring loaded in the closed position (figure 4.6.1) and must be manually set (opened, figure 4.6.2) each time the monitor base is deployed or re-located. To set (open) the safety valve, rotate the valve handle counter-clockwise until it locks into position, with the handle pointing straight back. If the safety valve trips, shut off the flow of water, and determine and correct the cause of trip before resetting safety valve. Probable causes include but are not limited to: low elevation angle, soft or uneven ground, excessive pump discharge pressure, inadequate anchoring, etc.

IMPORTANT NOTE: The safety valve responds only to vertical movement of the monitor. To prevent sliding, the monitor must be properly anchored, even with the safety valve option. See section 4.5 for correct anchoring procedure when using the monitor in the portable mode.

5.7 HOSE CONNECTION

Make the hose connection(s) to the portable base and extend the hose(s) straight back from the portable base at least 10 feet. If only one inlet of a double inlet base be used, a clapper valve will automatically close off the other inlet. Use caution when turning on the water to the monitor on the portable base. As the hose fills it will become stiff and may cause the monitor and portable base to slide or tip or both. Open the pump valve to the monitor slowly.

5.8 ELEVATION STOP PIN

When a nozzle is flowing water the reaction force acts in a straight line that is directly opposite the water flowing out the end of the nozzle. If a nozzle on a monitor on a portable base is pointed straight up, all of the reaction force is directed straight down and there is no sideways force that can cause the base to slide. As the nozzle is angled downward at the same flow, the reaction force remains the same, but some of that force becomes a force acting sideways and some acts in a downward direction. When the nozzle is at an angle of 45°, with respect to the base, the force acting sideways is equal to the force acting downward on the base. As the elevation angle of the nozzle is lowered, with respect to the base, the sideways force increases while the downward force decreases. At an angle of 35°, with respect to the base, (the angle at the elevation safety stop), approximately 82% of the nozzle reaction force is acting sideways on the base. When the nozzle is at a zero degree angle, with respect to the base, the entire reaction force is acting sideways on the base and there is no downward force at all. The lower the elevation angle of the nozzle, with respect to the base, the greater the force that causes sliding, and the more likely sliding will occur.

⚠ DANGER

Operating the monitor on a portable base below this safety stop is Dangerous. Do not operate on portable base below safety stop. Injury or death can occur if the monitor and base slide or lift off the ground.



5.9 ROTATION AND ROTATION LOCK

When the monitor is used on the portable base, keep the nozzle stream as close to in line with the anchor strap as possible to keep the reaction force of the nozzle on the strap. It is possible for the monitor to slide in an arc around the anchor point. The greater the horizontal angle between the strap and the nozzle stream, the greater the danger of sliding. When not rotating the monitor, keep the rotation lock locked.

⚠ DANGER

Operating On Portable Base Below This Stop (pin pulled) is Dangerous.

XL090

5.10 FLOWS & PRESSURES

See section 3.10.1. When the monitor is on the portable base do not exceed 1250 GPM (5000 l/min) or 175 PSI (12 bar). Testing conducted by Task Force Tips with five inch hose indicates that the use of a pressure relief valve is desirable, but not mandatory.



Unlocked



Locked

5.11 REMOVING MONITOR FROM BASE

To remove the monitor from it's base:

- a) Stop all water flow.
- b) Depress the safety plunger and lift the slide bar which will disengage the spring loaded pawls from the groove in the base.
- c) Lift the monitor straight up off the base by the handle on top of the monitor.

5.12 RETRACTING PORTABLE BASE LEGS

For carrying and storage, the legs are retracted as follows:

- a) Pull up on one of the spring loaded leg lock knobs, grasp the forward leg, on the same side, and push it, in an arc, towards the rear of the unit. The leg lock knob may be released as soon as the front leg begins to move out of position. Continue to push until both legs come in contact with the rear stop.
- b) Repeat procedure (a) to retract the other legs

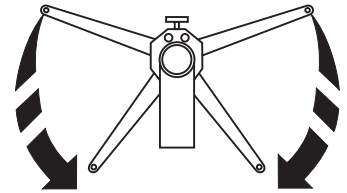

5.13 PORTABLE BASE STORAGE

The portable base may be stored in a compartment, on the optional storage bracket, TFT part number XF-B. This bracket is NOT designed to withstand the reaction forces of an operating monitor stream. It is to be used for storage and transportation only. The storage bracket may be mounted on a horizontal surface, horizontally or vertically on a vertical surface, or on the underside of a horizontal surface such as the top of a compartment. A strap helps hold the base on the bracket. Mounting instructions are supplied with the bracket.

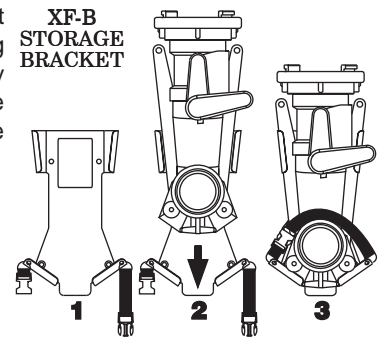

5.14 PRESSURE RELIEF OPTION

The optional pressure relief valve on the single inlet portable base can be adjusted to open between 50 and 200 psi. The pressure relief valve, TFT part A1810, is set at the factory to open at 150 psi. To change the relief pressure refer to the label on the bottom side of the pressure relief valve. A pressure relief valve can be added to the single inlet portable base by removing the cover on the side of the base. For additional information call 800-348-2686.

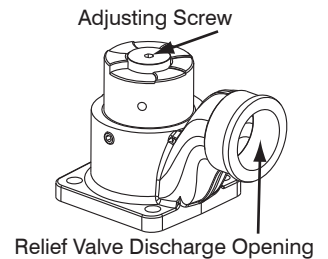

5.15 PRESSURE RELIEF VALVE SETTING

To set the relief valve pressure turn the adjusting screw on the relief valve housing until the surface of the screw is even with the desired pressure. Do not cap or plug discharge opening.

6.0 MAINTENANCE

The CROSSFIRE® monitor and its base require little maintenance. The unit should be kept clean and free of dirt by flushing with water after each use. All controls should be checked for freedom of movement and condition. Any inoperable or damaged part should be repaired or replaced immediately.

Specific areas to check are as follows:

Truck Mount Base:

- 1) Sealing surface above swivel joint must be smooth.
- 2) Swivel joint must rotate freely.

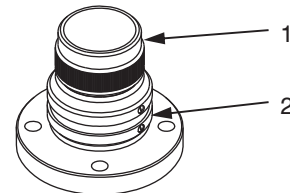

Portable Base:

- 1) Sealing surface above swivel joint must be smooth.
- 2) Swivel joint must rotate freely.
- 3) Safety Valve and trip paddle must move freely.
- 4) Legs and leg lock pins must move freely and lock in position.
- 5) Leg spikes must be sharp.
(replace if flats at tip of spikes exceed 1/16" diameter)

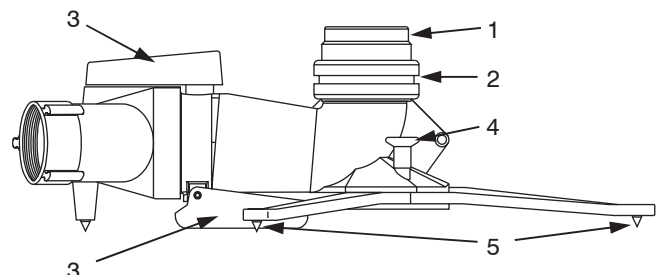

On surfaces with good traction a person's weight on the monitor and/or hose may be sufficient to keep the monitor from moving. This is highly dependant on the friction of the surface. The ability to keep one or more than one person's weight on the monitor is subject to operator fatigue and may not be as reliable as other methods. Operating at limited flows will reduce the risk.

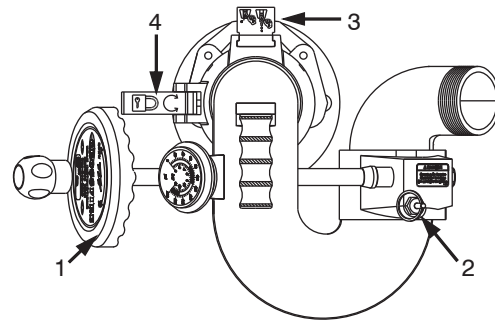

6.1 GREASE WORM GEAR

Turn the handwheel to move the nozzle to its highest elevation and pump grease (medium viscosity automotive) into the fitting in the worm gear housing until excess appears.

6.2 SAFETY VALVE TESTING

We recommend the following procedure to test the SAFE-TAK 1250 portable base safety valve.

- a) Set up monitor for normal operation. The base must be anchored (See section 4.5).
- b) Put a separate 2-1/2" or larger uncharged hose line or a rescue air bag under one leg. Attach at least 20 feet of air line if you are using a rescue bag.
- c) Point discharge straight ahead, at an elevation angle of approximately 60° with respect to the base. Set safety valve (section 4.6) and flow water as desired, up to 500 GPM.
- d) Charge the additional hoseline or inflate the rescue bag, from at least 20 feet away, until the safety valve trips. Valve trip is indicated by the valve handle moving to the tripped position and reduction of flow. If valve does not trip, stop all flow at pump and inspect valve and trip mechanism to determine the cause. If cause can not be determined, contact Task Force Tips at 1-800-348-2686 for additional assistance.
- e) Stay clear of the monitor during this test, as it will move when the valve trips.

6.3 PERFORMANCE TESTS

Performance tests shall be conducted on the Crossfire Monitor after a repair, or anytime a problem is reported to verify operation in accordance with Task Force Tips test procedures. Consult factory for the procedure that corresponds to the model and the serial number of the Monitor. Any equipment which fails the related test criteria should be removed from service immediately. Troubleshooting guides are available with each test procedure or equipment can be returned to the factory for service and testing.

7.0 SPECIFICATIONS

	CROSSFIRE Monitor	SAFE-TAK 1250 Base
Weight	17 lbs	24 lbs
Storage Volume	4060 in ³	1620 in ³
L-W-H	20 x 14-1/2 x 14	20 x 9 x 9
Height Above Truck Flange	12-1/2 in	NA
Height Above Truck Deck (min)	14 in	NA
Height Above Ground on Base	16-1/2 in	NA
Line of Reaction Force Above Ground	4 in	NA
Flow Area (minimum)	8.3 in ²	8.3 in ²
Maximum Flow	1250 GPM	1250 GPM
Maximum Pressure	175 PSI	175 PSI
Materials Used	Cast Aluminum, Aluminum, Stainless Steel	Cast Aluminum, Aluminum, Stainless Steel
Inlets Available	One	Numerous Single & Double Inlets 2-1/2 in - 5 in

7.0 DRAWINGS & PARTS LIST

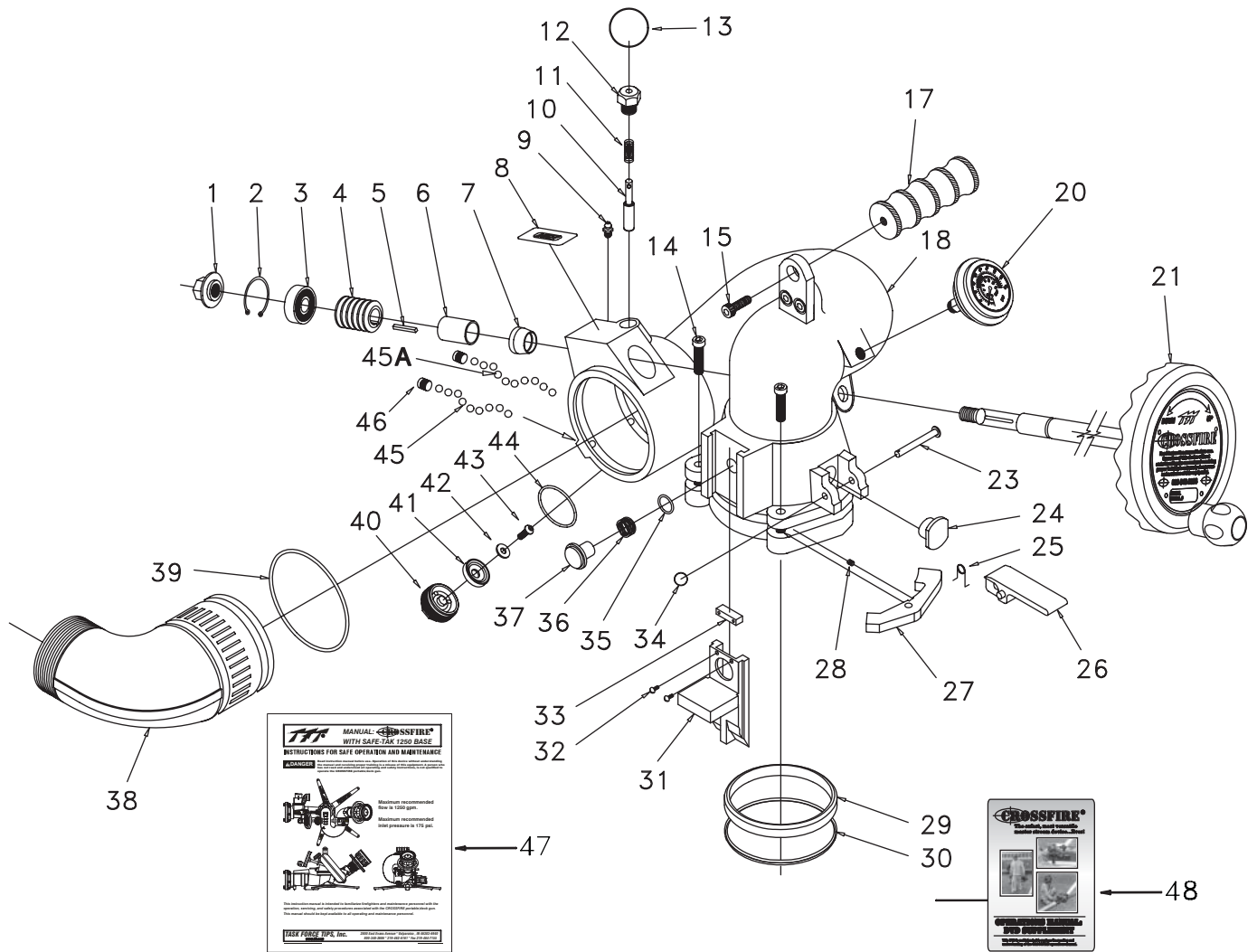

INDEX	DESCRIPTION	QTY	ITEM #
1	SHAFT NUT	1	X210
2	SNAP RING	1	VR4220
3	BEARING	1	VM4250
4	WORM WITH KEYWAY	1	X220
5	KEY 1/8 X 1.00	1	X225
6	BUSHING	1	X230
7	BOOT	1	X240
8	DANGER LABEL	1	XL090
9	11/4-28 GREASE FITTING	1	VT25-28ZERK
10	PULL PIN	1	X340
11	PULL PIN SPRING	1	X345
12	PULL PIN HOUSING	1	X350
13	KEY RING	1	X342
14	5/16-18 X 1-1/4 SHCS	2	VT31-18SH1.2
15	3/8-16X7/8SHCS	1	VT37-16SH875
17	PEG - CARRYING HANDLE	1	X362
18	BIG BEND/BELL ASSEMBLY	1	X800
20	200 PSI/BAR GAGE/BUMPER	1	X823
21	HANDWHEEL ASSEMBLY	1	X810
22	1/4 X 1-1/8 HDP SPIROL	1	VP250X1-375H
23	CLEVIS PIN 1/4 X 2	1	X180
24	ROTATION LOCK INSERT	1	X170
25	ROTATION LOCK SPRING	1	X152

INDEX	DESCRIPTION	QTY	ITEM #
26	ROTATION LOCK LEVER	1	X821
27	PAWL	2	X135
28	DETENT SPRING	2	H770
29	WEAR STRIP	1	X120
30	CUP SEAL .366 NITRILE 70A	1	X125
31	SLIDE BAR	1	X140
32	#6-32 X 1/4 BUTTON HEAD	2	VT06E32BH250
33	COVER	1	X142
34	CLEVIS PIN RETAINER	1	X137
35	O-RING-018	1	VO-016
36	PLUNGER WAVE SPRING	1	X165
37	SAFETY PLUNGER	1	X150
38	2.5 NH ELBOW	1	X339NJ
39	O-RING-241	1	VO-241
40	DRAIN HOUSING	1	X375
41	DRAIN VALVE	1	X382
42	FLAT WASHER	1	VW687X281-50
43	1/4-28 X 1/2 BHCS	1	VT25-28BH500
44	O-RING 130	1	VO-130
45	5/16 SS BALLS	38	VB.312
45A	5/16 TORLON BALLS	38	VB.312TO
46	3/8-24 x 3/8 SOCKET SET	2	VT37F24SS312
47	MANUAL CROSSFIRE	1	LIX-030
48	DVD - CROSSFIRE	1	LIX-200

SAFE-TAK 1250®

with Safety Valve

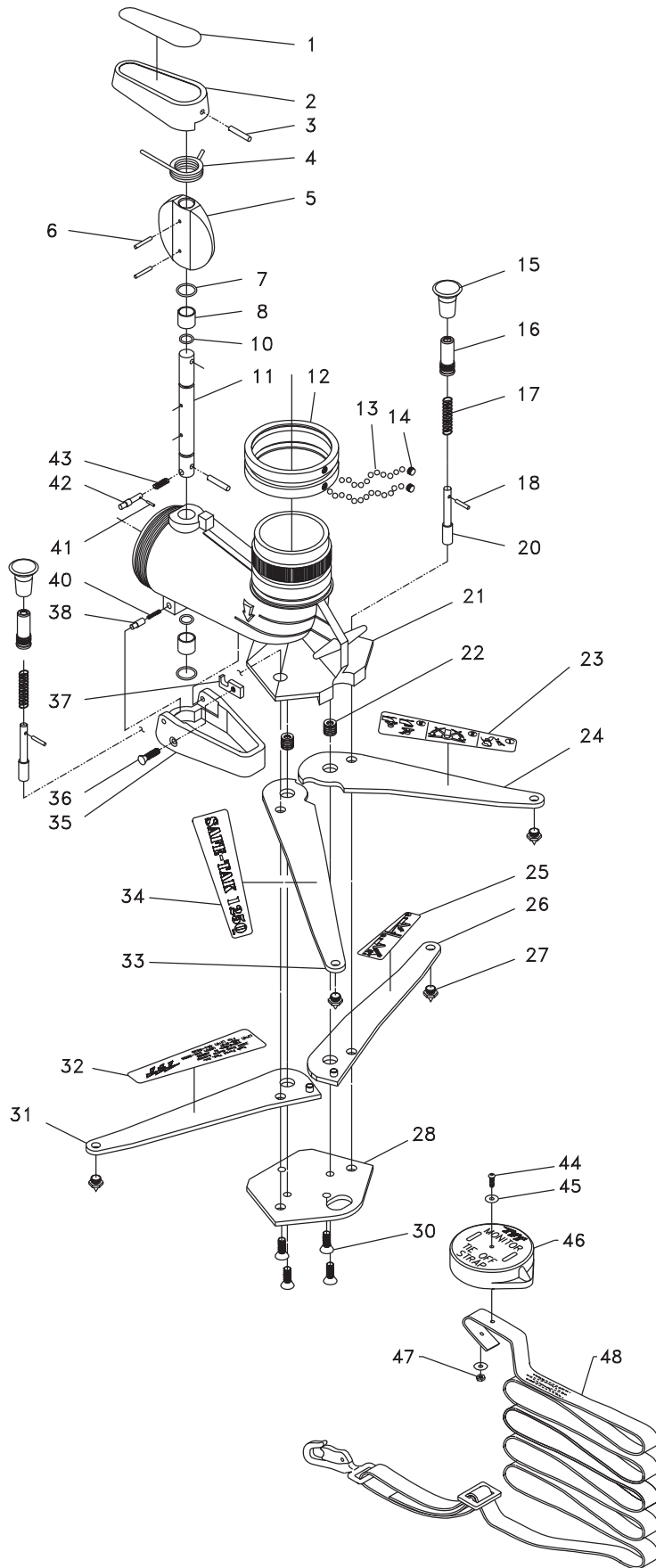

INDEX	DESCRIPTION	QTY	ITEM #
1	SAFETY VALVE HANDLE LABEL	1	XL070
2	VALVE HANDLE	1	X540
3	1/4 x 1 3/8 SPIROL PIN	1	VP250X1.375H
4	TORSION SPRING	1	X560
5	BUTTERFLY	1	X550
6	5/32 x 1 1/8 SPIROL PIN	2	V1920
7	O-RING-118	2	VO-118
8	BUSHING	2	X565
10	O-RING-113	2	VO-113
11	VALVE SHAFT	1	X570
12	SWIVEL RING	1	X425
13	5/16 SS BALLS	76	VB.312
14	SWIVEL SCREW	2	X405
15	SHOT PIN KNOB	2	X430
16	KNOB BARREL	2	X440
17	SHOT PIN SPRING	2	X445
18	5/32 x 7/8 SPIROL PIN	2	V1900
20	SHOT PIN	2	X435
21	BASE	1	X420
22	BELLEVILLE WASHER	12	D07590
23	INSTRUCTION LEG LABEL 1-3	1	XL010
24	FRONT LEG - LEFT	1	X470L
25	INSTRUCTION LEG LABEL 4-5	1	XL020
26	REAR LEG - LEFT	1	X460L
27	SPIKE	4	X480
28	BOTTOM PLATE	1	X450
30	3/8-16 x 3/4 FLAT HEAD SHCS	4	VT37-16FH750
31	REAR LEG - RIGHT	1	X460R
32	TFT LEG LABEL	1	XL050
33	FRONT LEG - RIGHT	1	X470R
34	SAFE-TAK LEG LABEL	1	XL040
35	PADDLE	1	X530
36	1/4-20 x 7/8 FLAT HEAD	1	VT25E20FH875
37	WEAR PLATE	1	X585
38	PADDLE PIVOT	2	X590
40	PADDLE PIVOT SPRING	2	X575
41	3/32 x 1/2 SPIROL PIN	1	VP094X500H
42	TRIP PIN	1	X580
43	TRIP PIN SPRING	1	X582
44	#10-32 x 7/8 BUTTON HEAD	1	VT10E32BH875
45	WASHER	2	VW700X203-60
46	STRAP CAP	1	X457
47	#10-32 HEX NUT	1	VT10-32NT
48	STRAP ASSEMBLY	1	X455 -R

DOUBLE INLET OPTION

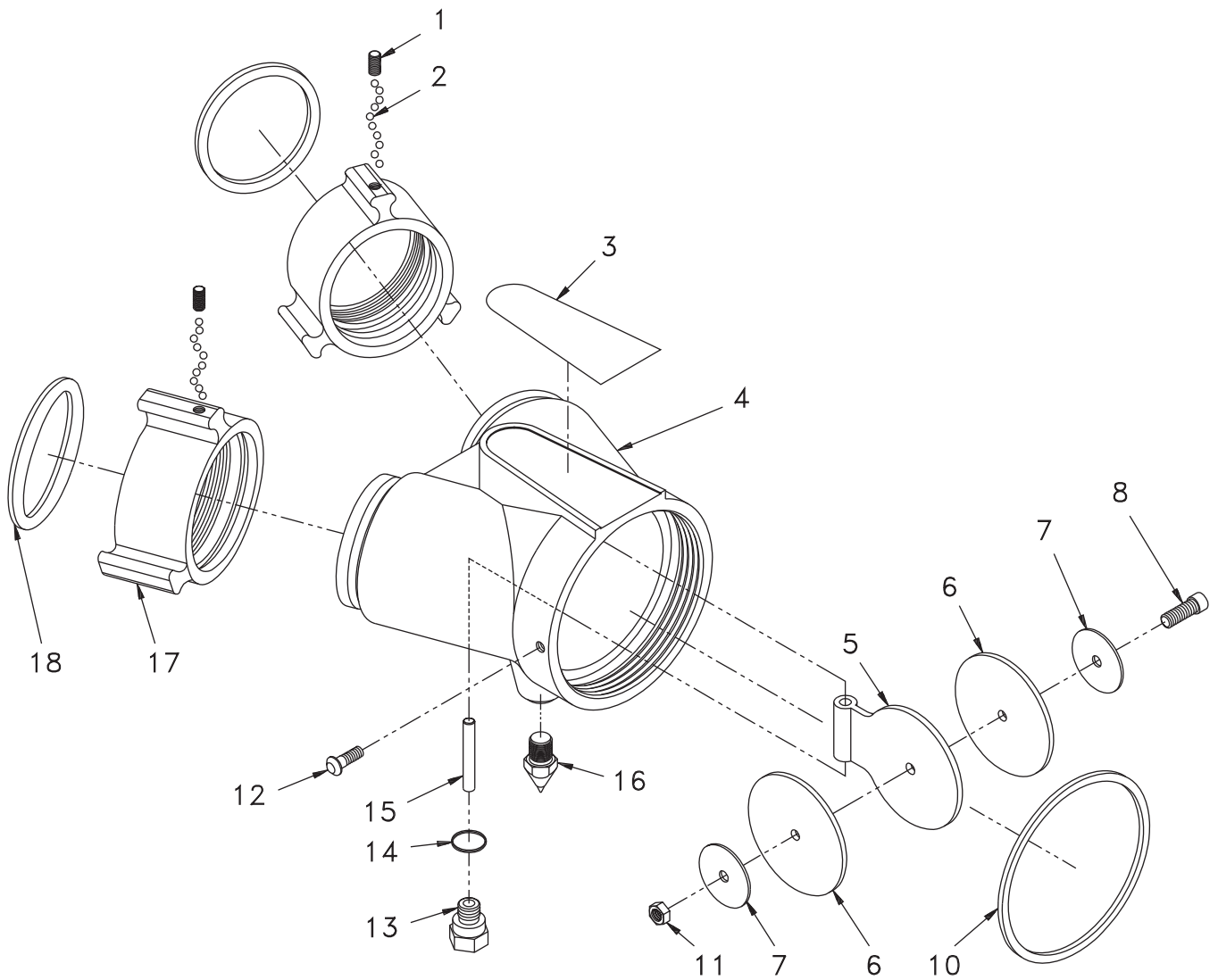

INDEX	DESCRIPTION	QTY	ITEM #
1	1/4-28 x 1/2 SOCKET SET	2	VT25-28SS500
2	3/16 SS BALL	96	V2120
3	SAFETY VALVE BASE LABEL	1	XL080
	NO VALVE BASE LABEL		XL085
4	2.5" WYE	1	X712
5	2.5" CLAPPER	1	X772
6	2.5" CLAPPER GASKET	2	X762
7	WASHER	2	VW1.9x26-076
8	1/4-20 x 1 SHCS, SS	1	VT25-20SH1.0
10	O-RING-244	1	VO-244
11	1/4-20 STAINLESS NUT	1	VT25-20NT
12	1/4-28 X 3/4 BUTTON HEAD	1	VT25-28BH750
13	PIVOT BOLT	1	X784
14	O-RING-013	1	VO-013
15	CLAPPER PIVOT	1	X732
16	REAR SPIKE	1	X482
17	2.5" NH COUPLING (pictured)	2	M307N
18	2.5" COUPLING GASKET (pictured)	2	V3190

HIGH FLOW INLET OPTION

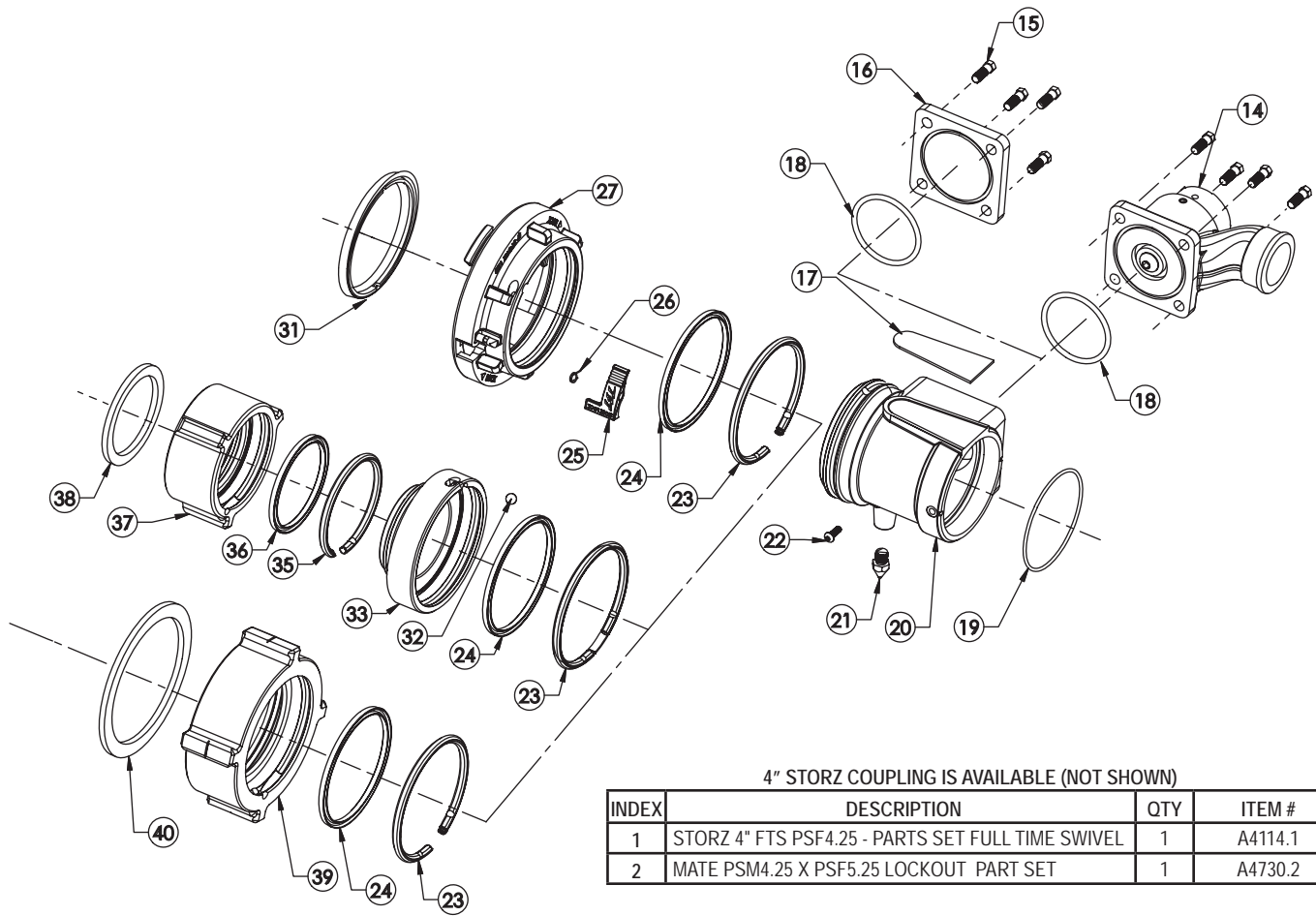

4" STORZ COUPLING IS AVAILABLE (NOT SHOWN)

INDEX	DESCRIPTION	QTY	ITEM #
1	STORZ 4" FTS PSF4.25 - PARTS SET FULL TIME SWIVEL	1	A4114.1
2	MATE PSM4.25 X PSF5.25 LOCKOUT PART SET	1	A4730.2

INDEX	DESCRIPTION	QTY	ITEM #
14	RELIEF VALVE WITHOUT THREAD, ALUMINUM	1	A1810
15	7/16-14 X 1 HEX HEAD BOLT 18-8 STAINLESS STEEL	4	VT43-14HX1.0
16	LDH BLANK CAP HARDCOAT USE ON X651	1	X631
17	SAFETY VALVE BASE LABEL	1	XL080
18	O-RING-236 3-1/4 ID 1/8 C/S 3.234 +/- .024 ID.139 +/- .004 C/S	1	VO-236
19	O-RING-244 4-1/4 ID 1/8 C/S 4.234 +/- .030 ID .139 +/- .004 C/S	1	VO-244
20	LDH ADAPTOR W/PSM5.25	1	X651
21	REAR SPIKE	1	X482
22	1/4-28 X 3/4 BUTTON HEAD - ND PATCH	1	VT25Y28BH750
23	PLASTIC STRIP 5.25" - MOLDED	1	A1291
24	CUP SEAL 5.25 X 4.75 X 1/4 PRECISION ASSOCIATES #666-427	1	A1296
25	LOCKING LEVER - MOLDED	1	A4176
26	SPRING TORSION (STORZ LOCK) 9991067 MIDSTATE # 210049	1	A4230
27	COUPLING HEAD STORZ 5 X 5.25 PSF HARDCOAT	1	A4135
31	GASKET 5" PRESSURE MOLDED 9991000	1	A4220
32	BALL 7/16 STAINLESS 302 GRADE 100	1	VB.437
33	MATE PSM4.25 X PSF5.25 - HARDCOAT	1	A4730
35	PLASTIC STRIP 4.25" - MOLDED	1	A1292
36	CUP SEAL 4.25 X 3.750 X 1/4	1	A1297
37	COUPLING RL 3.0NH X PSF4.25	1	A4650N
37	COUPLING RL 3.5NH X PSF4.25	1	A4655N
38	GASKET 3.0 HOSE COUPLING	1	V3194
38	GASKET 3.5 HOSE COUPLING	1	V3196
39	4.0 NH FEMALE X PSF5.25	1	A4660N
40	4.0 HOSE COUPLING GASKET	1	V3198

9.0 WARRANTY

Task Force Tips, Inc., 3701 Innovation Way, Valparaiso, Indiana 46383-9327 ("TFT") warrants to the original purchaser of its Crossfire Monitor and Safe-Tak 1250 Base ("equipment"), and to anyone to whom it is transferred, that the equipment shall be free from defects in material and workmanship during the five (5) year period from the date of purchase.

TFT's obligation under this warranty is specifically limited to replacing or repairing the equipment (or its parts) which are shown by TFT's examination to be in a defective condition attributable to TFT. To qualify for this limited warranty, the claimant must return the equipment to TFT, at 3701 Innovation Way, Valparaiso, Indiana 46383-9327, within a reasonable time after discovery of the defect. TFT will examine the equipment. If TFT determines that there is a defect attributable to it, it will correct the problem within a reasonable time. If the equipment is covered by this limited warranty, TFT will assume the expenses of repair.

If any defect attributable to TFT under this limited warranty cannot be reasonably cured by repair or replacement, TFT may elect to refund the purchase price of the equipment, less reasonable depreciation, in complete discharge of its obligations under this limited warranty. If TFT makes this election, claimant shall return the equipment to TFT free and clear of any liens and encumbrances.

This is a limited warranty. The original purchaser of the equipment, any person to whom it is transferred, and any person who is an intended or unintended beneficiary of the equipment, shall not be entitled to recover from TFT any consequential or incidental damages for injury to person and/or property resulting from any defective equipment manufactured or assembled by TFT. It is agreed and understood that the price stated for the equipment is in part consideration for limiting TFT's liability. Some states do not allow the exclusion or limitation of incidental or consequential damages, so the above may not apply to you.

TFT shall have no obligation under this limited warranty if the equipment is, or has been, misused or neglected (including failure to provide reasonable maintenance) or if there have been accidents to the equipment or if it has been repaired or altered by someone else.

THIS IS A LIMITED EXPRESS WARRANTY ONLY. TFT EXPRESSLY DISCLAIMS WITH RESPECT TO THE EQUIPMENT ALL IMPLIED WARRANTIES OF MERCHANT ABILITY AND ALL IMPLIED WARRANTIES OF FITNESS FOR A PARTICULAR PURPOSE. THERE IS NO WARRANTY OF ANY NATURE MADE BY TFT BEYOND THAT STATED IN THE DOCUMENT.

This limited warranty gives you specific legal rights, and you may also have other rights which vary from state to state.

Visit TFT's web site at www.tft.com

10.0 OPERATION CHECKLIST

Monitor must be inspected for proper operation and function according to this checklist before each use. Before flowing water check:

GENERAL

- 1 There is no obvious damage such as missing, broken, or loose parts.
- 2 Hose(s) and nozzle are securely attached.

MONITOR TOP

- 7 Monitor top is securely attached.

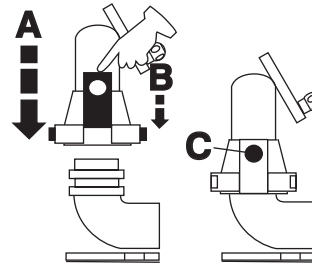

PORTABLE BASE

- 3 Legs are fully opened and locked in place.
- 4 All leg spikes are in contact with the ground.

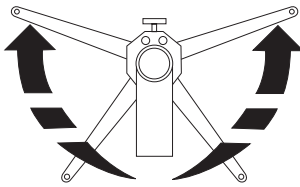

- 8 Nozzle elevation is above safety stop.
- 9 Elevation handwheel adjusts elevation freely.



- 5 Monitor is securely tied down with no slack in anchor strap.

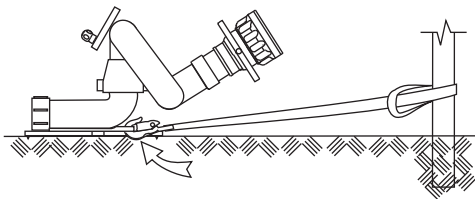

- 10 Monitor top freely swivels on base when unlocked.
- 11 Rotation lock lever securely locks rotation.

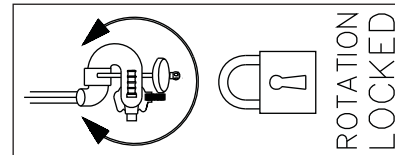

- 6 Safety valve operates freely.

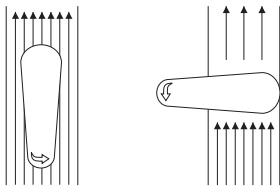

- 12 Monitor is pointed in a safe direction.

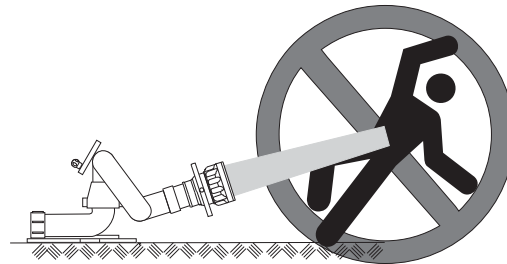

WARNING

Any monitor failing any part of the inspection checklist is unsafe and must have the problem corrected before use. Operating a monitor that fails any of the above inspections is a misuse of this equipment.

TASK FORCE TIPS, INC.
MADE IN USA • www.tft.com

3701 Innovation Way, Valparaiso, IN 46383-9327 USA
800-348-2686 • 219-462-6161 • Fax 219-464-7155