

## INSTRUCTIONS FOR SAFE OPERATION AND MAINTENANCE

### **WARNING**

Read Instruction Manual before use. Operation of this manifold without understanding the manual and receiving proper training can be dangerous and is a misuse of this equipment. Download this manual from <http://tft.com/>. Call 800-348-2686 with any questions.

### **NOTICE**

This Instruction Manual is intended to familiarize firefighters and maintenance personnel with the operation, servicing, and safety procedures associated with the 5-Way Manifold.

### **NOTICE**

This manual should be kept available to all operating and maintenance personnel.

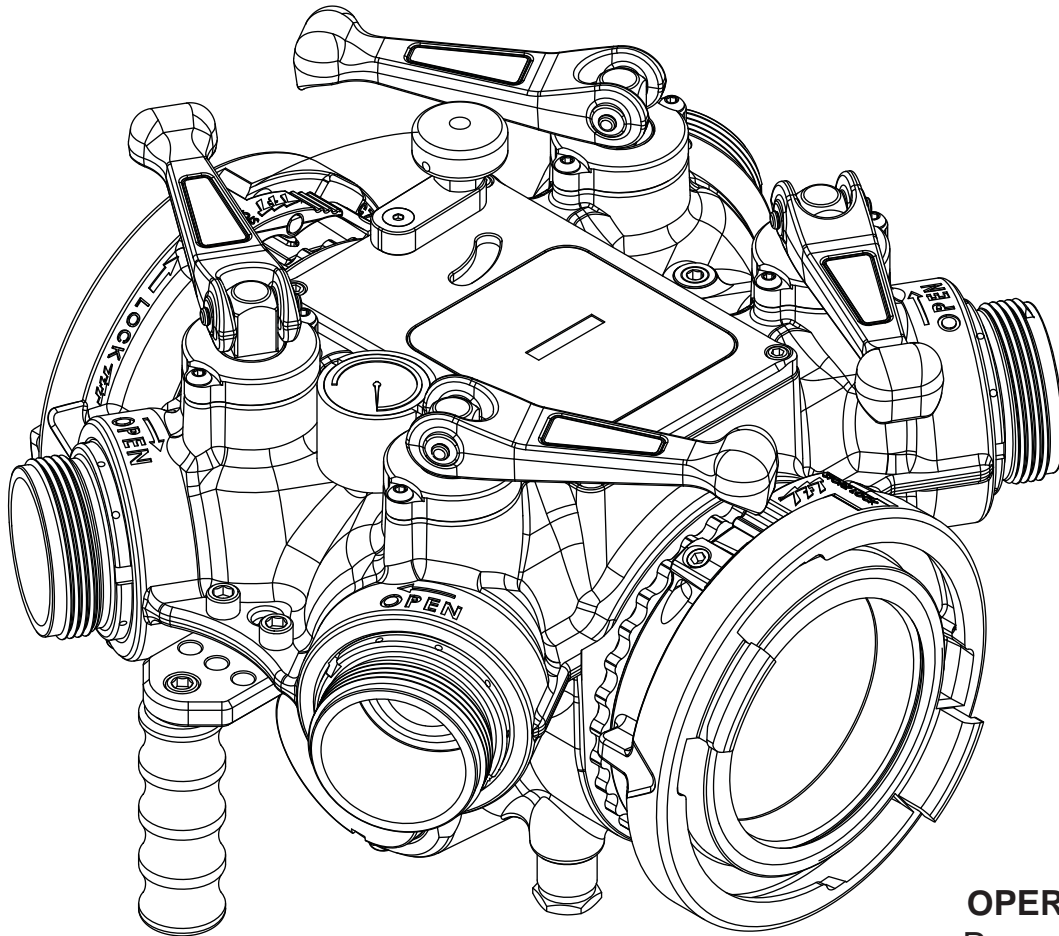

**OPERATING RANGE**  
Pressure Max 300 PSI  
Pressure Min 10 PSI

## Table Of Contents

- 1.0 MEANING OF SAFETY SIGNAL WORDS
- 2.0 SAFETY
- 3.0 GENERAL INFORMATION
  - 3.1 VALVE SPECIFICATIONS
  - 3.2 CORROSION
  - 3.3 USE WITH SALT WATER
  - 3.4 LOW TEMPERATURE USE
  - 3.5 AIR FLUSH PORT
  - 3.6 PRESSURE RELIEF VALVE
  - 3.7 VALVE STORAGE BRACKET
  - 3.8 FEATURE IDENTIFICATION
- 4.0 USE
  - 4.1 INSTALLING AND USING THE MANIFOLD
  - 4.2 PRESSURE LOSS
- 5.0 MAINTENANCE
- 6.0 EXPLODED VIEWS
  - 6.1 MAIN VALVE ASSEMBLY
  - 6.2 MAIN VALVE ASSEMBLY PARTS LIST
  - 6.3 INLET COMPONENTS PARTS LIST
  - 6.4 OUTLET COMPONENTS PARTS LIST
  - 6.5 PRESSURE RELIEF VALVE COMPONENTS PARTS LIST
  - 6.6 2.5" VALVE COMPONENTS PARTS LIST
- 7.0 WARRANTY
- 8.0 ANSWERS TO YOUR QUESTIONS



### PERSONAL RESPONSIBILITY CODE

The member companies of FEMSA that provide emergency response equipment and services want responders to know and understand the following:

1. Firefighting and Emergency Response are inherently dangerous activities requiring proper training in their hazards and the use of extreme caution at all times.
2. It is your responsibility to read and understand any user's instructions, including purpose and limitations, provided with any piece of equipment you may be called upon to use.
3. It is your responsibility to know that you have been properly trained in Firefighting and /or Emergency Response and in the use, precautions, and care of any equipment you may be called upon to use.
4. It is your responsibility to be in proper physical condition and to maintain the personal skill level required to operate any equipment you may be called upon to use.
5. It is your responsibility to know that your equipment is in operable condition and has been maintained in accordance with the manufacturer's instructions.
6. Failure to follow these guidelines may result in death, burns or other severe injury.



Fire and Emergency Manufacturers and Service Association  
P.O. Box 147, Lynnfield, MA 01940 • [www.FEMSA.org](http://www.FEMSA.org)

## 1.0 MEANING OF SAFETY SIGNAL WORDS

A safety related message is identified by a safety alert symbol and a signal word to indicate the level of risk involved with a particular hazard. Per ANSI standard Z535.6-2006, the definitions of the four signal words are as follows:



**DANGER** indicates a hazardous situation which, if not avoided, will result in death or serious injury.



**WARNING** indicates a hazardous situation which, if not avoided, could result in death or serious injury.



**CAUTION** indicates a potentially hazardous situation which, if not avoided, may result in minor or moderate injury.



**NOTICE** is used to address practices not related to personal injury.

## 2.0 SAFETY



Quick changes to the side port valve position can cause high pressure spikes due to water hammer and may result in damaged equipment which could lead to injury or death. Open and close the side port valves slowly to avoid water hammer.



Injury or death may occur by attempting to use a damaged valve. Per NFPA 1962, the device shall be inspected and tested at least quarterly. Before use, inspect for damage resulting from:

- Failure to drain valve followed by exposure to freezing conditions
- Exposure to temperatures in excess of 160 degrees F
- Missing parts, physical abuse



This equipment is intended for use by trained personnel for firefighting. Its use for other purposes may involve hazards not addressed by this manual. Seek appropriate guidance and training to reduce risk of injury.



Kinks in supply hose may reduce water flow and cause injury or death to persons dependent on water flow. Avoid tight bends to minimize risk of hose line kinks.



The 5-Way Manifold is not rated for use in explosive atmospheres.



The valve may be damaged if frozen while containing significant amounts of water. Such damage may be difficult to detect visually and can lead to possible injury or death. Any time the valve is subject to possible damage due to freezing, it must be hydrostatically tested by qualified personnel before being considered safe for use.



Minimum operating pressure 10 psi. Inadequate water pressure will prevent valve from opening and may result in a lack of water flow and cause injury or death to persons dependent on water flow. Ensure there is adequate water pressure supplied to inlet of valve.



Maximum operating pressure is 300 psi (20 bar). Exceeding 300 psi (20 bar) on either side of the valve may damage valve and could cause injury.



Valve must be properly connected. Mismatched or damaged connectors may cause leaking or uncoupling under pressure and could cause injury.



Any alterations to the valve and its markings could diminish safety and constitutes a misuse of this product.



Dissimilar metals coupled together can cause galvanic corrosion that can result in the inability to unscrew the threads and complete loss of thread engagement over time. Per NFPA 1962 section 6.2 (2008 edition), if dissimilar metals are left coupled together, an anti corrosive lubricant such as Dow Corning 112 Silicone Grease should be applied to the threads. Also, the coupling should be disconnected and inspected at least quarterly.

### 3.0 GENERAL INFORMATION

The 5-Way Manifold is a compact, portable, low friction-loss valve that can be used in many water distribution applications. The hydraulically actuated slide valve combined with four of TFT's 2.5" quarter-turn ball valves with folding handles make for the ultimate in versatility. All four 2.5" valves can be used with or without the LDH valve being open. Valve seats are field replaceable, and quarter-turn folding valve handles require low force to move, even under pressure. The automatic valve lock on the 2.5" valves maintain valve position while flowing at partial openings. Folding handles minimize required storage space. Device includes a pressure gage, PRV, and carrying handle. A polymer bearing ring helps prevent galvanic corrosion on LDH couplings. Storage bracket available.

### 3.1 VALVE SPECIFICATIONS

Length: 16" (406mm)

Width: 17.5" (445mm)

Height: 11.5" (292mm)

Weight: 48lbs (21.8kg)

Main LDH Waterway size (at valve seat): 4.5" (114 mm)

Side ports (4) waterway: 2.5" (63.5mm)

LDH valve meets NFPA 1965 2009 3.3.11.3 Slow-Operating Valve Requirement. (Side discharges do not slow-operate)

Minimum Operating Pressure: 10 psi (0.7 Bar) LDH VALVE NOT FOR SUCTION USE.

Maximum Operating Pressure: 300 psi (20 bar)

Hydrostatic Proof Test Pressure: 900 psi (62 bar)

Temperature Rating\*: -25°F to 135°F (-32°C to 57°C)

\*For temperatures below 32°F (0°C), valves must be drained after use to avoid damage.

See section [3.4 LOW TEMPERATURE USE](#)

### 3.2 CORROSION

Hose couplings are attached using polymer bearing rings which provides electrical insulation to help prevent galvanic corrosion. The valve body is hard anodized, and powder coated to help prevent corrosion. The effects of corrosion can be minimized by good maintenance practice. See section [3.5 AIR FLUSH PORT](#) & [5.0 MAINTENANCE](#).

### 3.3 USE WITH SALT WATER

Use with salt water is permissible provided valve is thoroughly cleaned with fresh water after each use. The service life of the valve may be shortened due to the effects of corrosion and is not covered under warranty.

### 3.4 LOW TEMPERATURE USE

The valve is designed with self-draining waterways. In extreme freezing conditions, extra precautions should be taken to ensure control waterways remain free from ice. Residual water should be cleared from the valve after each use. See section [3.5 AIR FLUSH PORT](#).

### 3.5 AIR FLUSH PORT

The valve is equipped with an air flush port. Remove the cap. Use a Schrader air chuck to apply a minimum of 20 psi (1.4 bar) to the air flush port. Open and close the control valve. Residual water will be forced out through the filter and control valve bleed drain.



**The sliding plug is pinch hazard that can cause injury. Keep hands and fingers outside of the valve any time air is applied to air flush port.**

### 3.6 PRESSURE RELIEF VALVE

LDH valved appliances may be equipped with a pressure relief valve that can be set to any pressure between 50 and 200 psi. Its function is to protect the pump and supply hose from excess pressure. See [LIA-202 PRESSURE RELIEF VALVE INSTRUCTIONS FOR SAFE OPERATION AND MAINTENANCE](#).

### 3.7 VALVE STORAGE BRACKET

A storage bracket is available for the 5-Way Manifold. The valve can be stored with hose pre-connected to the inlet and/or outlet of the valve. The storage bracket can be mounted vertically or horizontally with the included self-tapping stainless steel screws. The bracket requires 12.5" x 11.1" (317.5mm x 281.9mm) of panel space. To purchase a bracket, order TFT part number AU-BRACKET.

### 3.8 FEATURE IDENTIFICATION

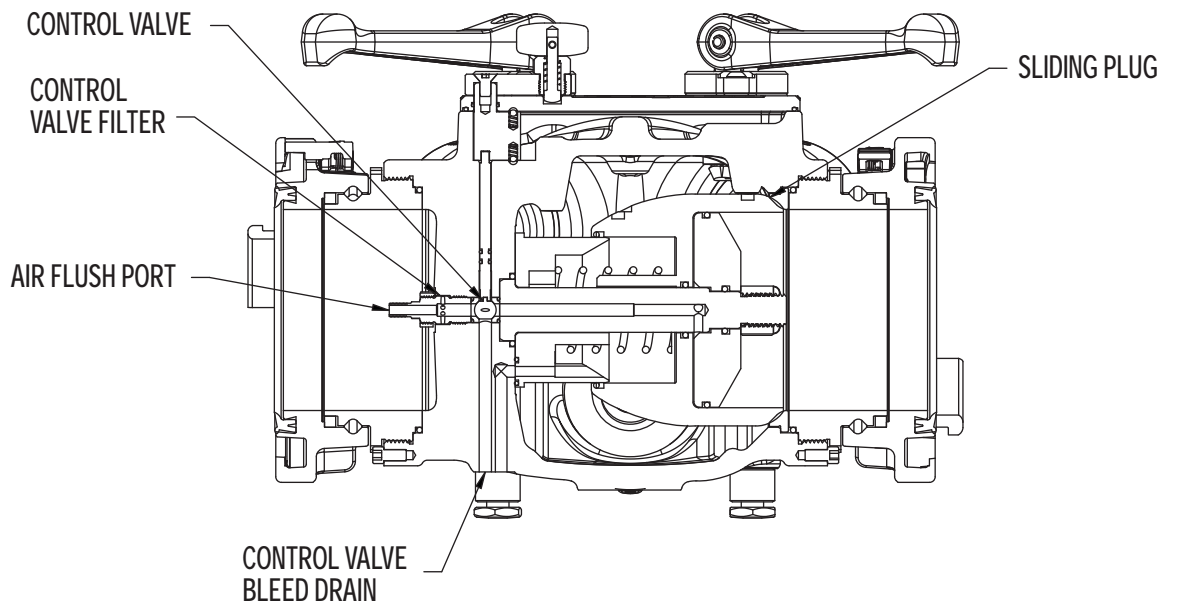
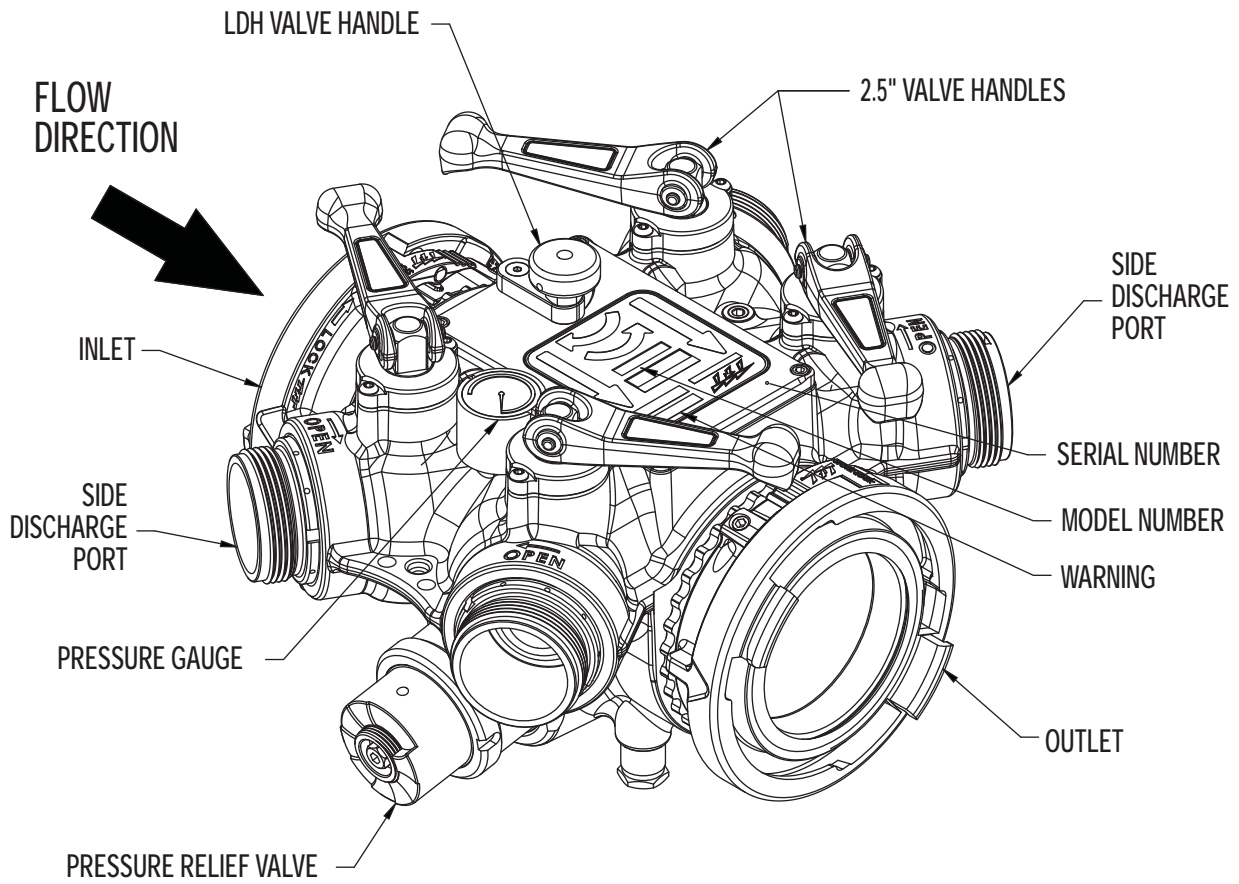

## 4.0 USE

### 4.1 INSTALLING AND USING THE MANIFOLD

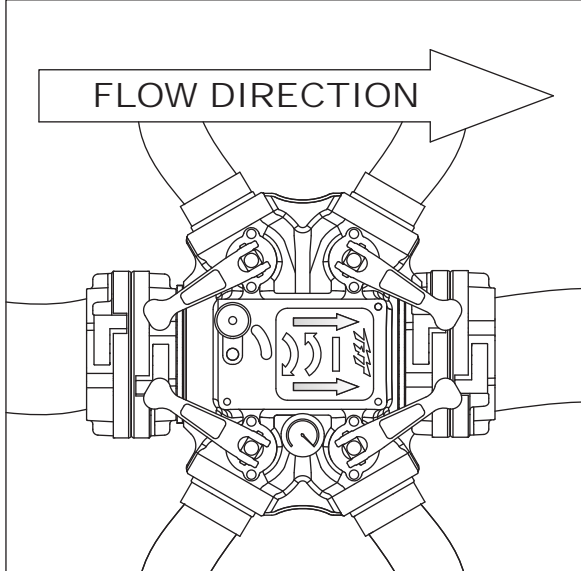
<p>Make connections to each port to be used.</p> <p>Ensure that flow will move in the direction indicated on the valve.</p>	<p><b>⚠ WARNING</b></p> <p>Valve will not properly open or close if flow direction does not match arrow printed on exterior of valve. Reducing or interrupting of flow may cause injury or death to persons dependent on water flow.</p>	
<p>Verify that all discharge ports are closed by rotating all valve handles to the CLOSED position.</p> <p>Pressurize manifold.</p>	<p><b>⚠ CAUTION</b></p> <p>Pressurizing manifold with discharge ports open can cause injury by unintentionally charging hose lines. Open ports as needed.</p>	

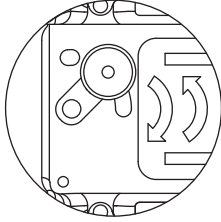
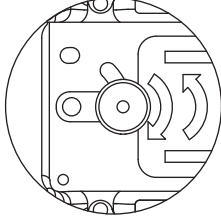
<p>When flow from the LDH discharge port is required, rotate the handle clockwise to the first position for a slower opening speed, or to the second position for a normal opening speed. LDH valve handle opens control valve, allowing water pressure to build in control chamber and move sliding plug fully open. Both positions meet NFPA slow operating requirements. Rapid changes to handle position will not defeat the slow-operating feature.</p>	<p><b>⚠ WARNING</b></p> <p>Minimum operating pressure 10 psi. Inadequate water pressure will prevent valve from opening and may result in a lack of water flow and cause injury or death to persons dependent on water flow. Ensure there is adequate water pressure supplied to inlet of valve.</p>	 <p><b>Valve Handle in Closed Position</b></p>
		 <p><b>Valve handle in Slow Open Position</b></p>
		 <p><b>Valve handle in Normal Open Position</b></p>

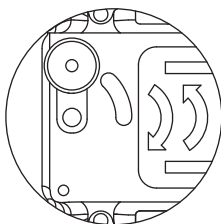
<p>To stop flow from the LDH valve discharge port, rotate the LDH valve handle to the closed position. LDH valve handle closes control valve, allowing water from control chamber to drain to ground and slowly close sliding plug.</p>	 <p><b>Valve handle in closed position</b></p>
---	---



## 4.2 PRESSURE LOSS

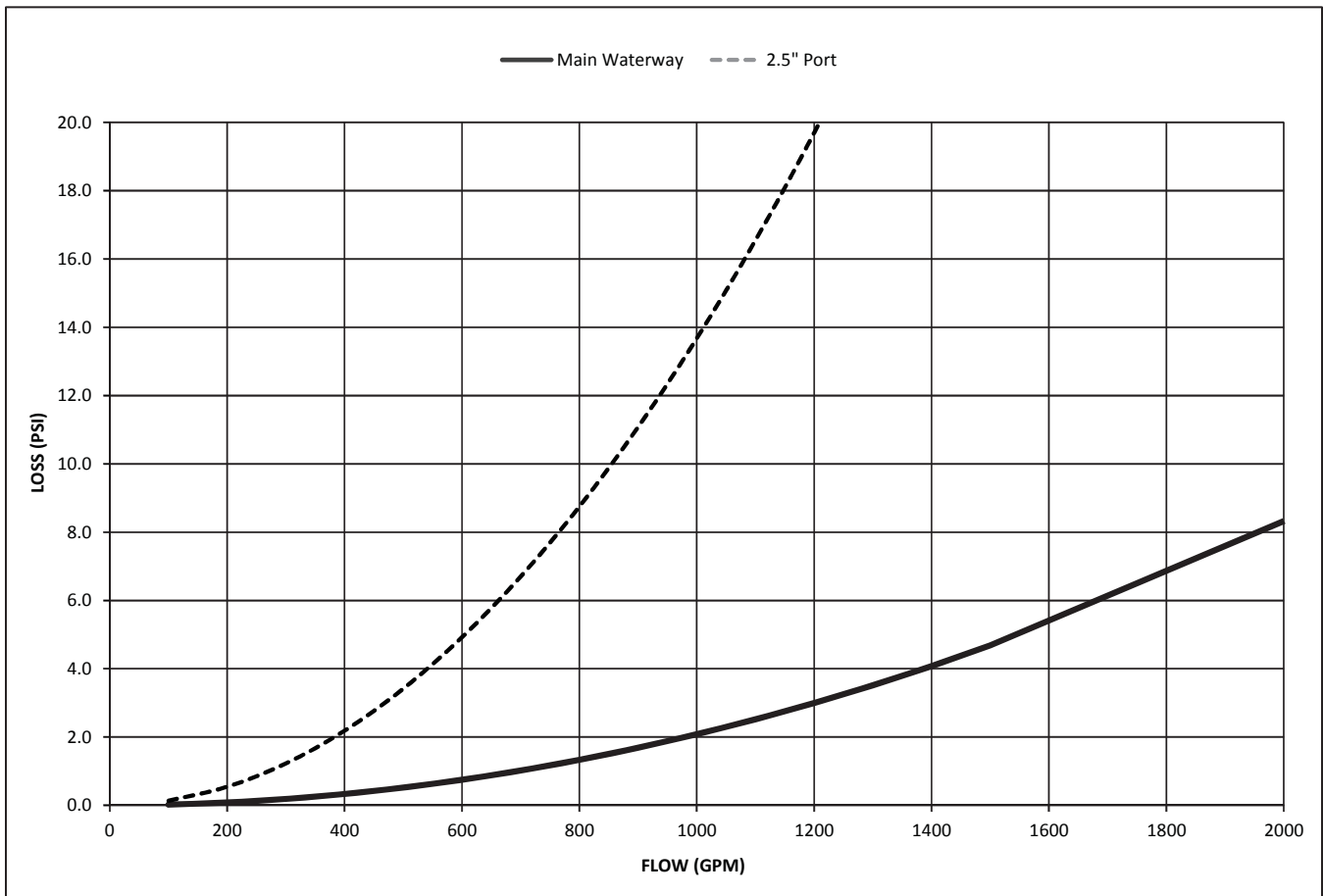

## 5.0 MAINTENANCE

This valve should be disconnected, cleaned and visually inspected inside and out at least quarterly for proper function per NFPA 1962 2008 Section 8.2, or as water quality and use may require. Moving parts should be checked for smooth and free operation. Seals shall be greased as needed with silicone-based grease such as Dow Corning 112. Any scrapes that expose bare aluminum should be cleaned and touched up with enamel paint such as Rust-Oleum.

Keys point of inspection:

- There is no damage such as cracks or dents
- There is no corrosion
- The waterway is clear of obstructions
- The sliding plug moves freely (Use Air Flush Port to test according to section [3.5 AIR FLUSH PORT](#))

Replace any missing or damaged parts before returning to service. Any repaired device must be tested before being placed in service.



**Any alterations to the device and its markings could diminish safety and constitute a misuse of this product.**

# 6.0 EXPLODED VIEWS

## 6.1 MAIN VALVE ASSEMBLY

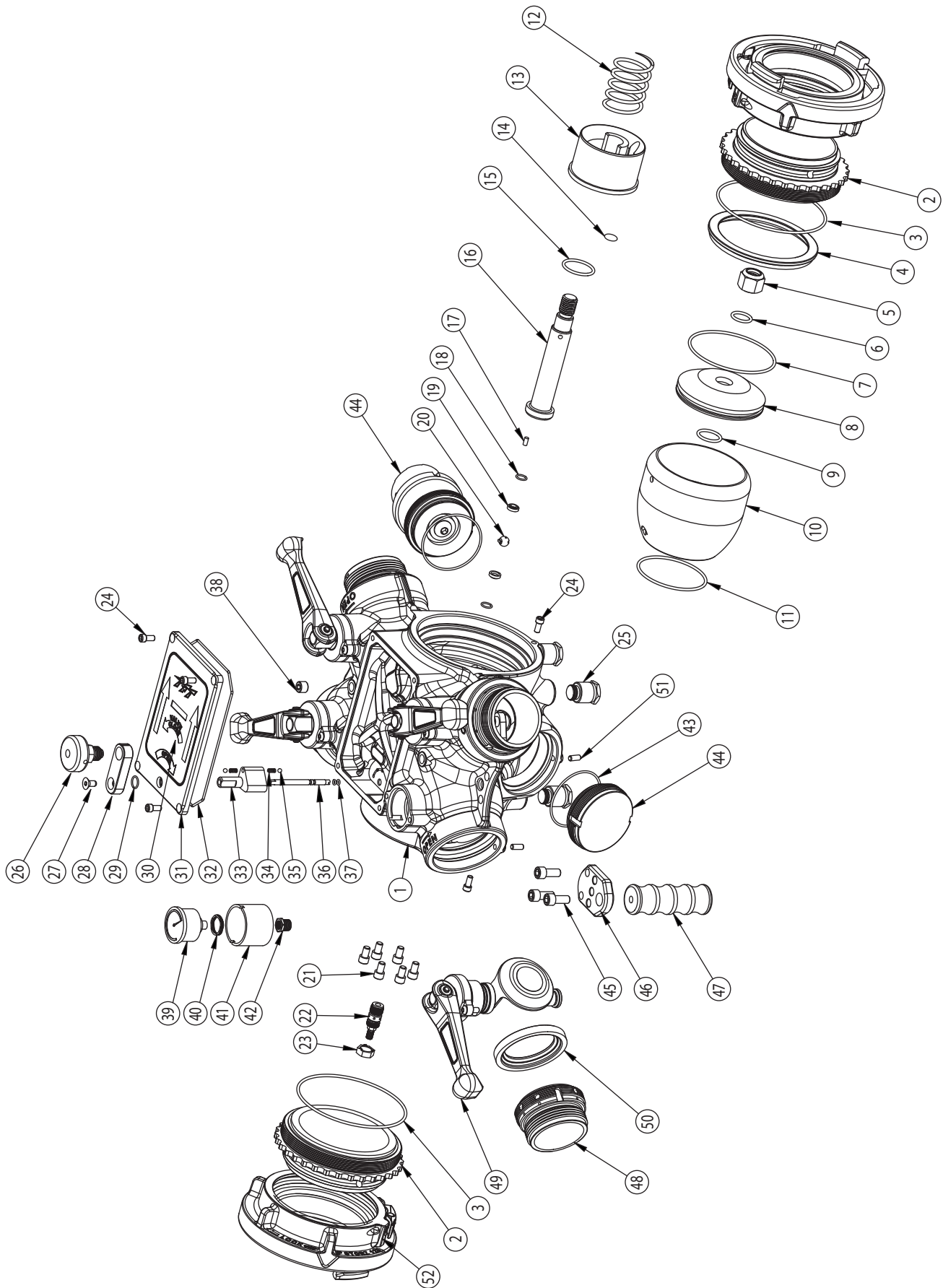



## 6.2 MAIN VALVE ASSEMBLY PARTS LIST

ID	QTY	PART #	DESCRIPTION
1	1	A2105	5 WAY MANIFOLD BODY
2	2	A2115	OUTLET PSM5.25
3	2	VO-252	O-RING-252
4	1	A2114	VALVE SEAT
5	1	VT75-10LNT	3/4" LOCK NUT - 18-8 SS
6	1	VO-211	O-RING-211
7	1	VO-243	O-RING-243
8	1	A2113	VALVE SHAFT END
9	1	VO-214	O-RING-214
10	1	A2112	SLIDING PLUG
11	1	VO-236	O-RING-236
12	1	A2126	RETURN SPRING
13	1	A2111	VALVE SLEEVE
14	1	VO-111	O-RING-111
15	1	VO-220	O-RING-220
16	1	A2110	VALVE SHAFT
17	1	VP188X.375	DOWEL PIN .1875 DIA X .375
18	2	VO-013	O-RING-013
19	2	A2121	CONTROL VALVE SEAT
20	1	A2150	CONTROL BALL VALVE - NON-RC
21	6	VT31-18SH500	5/16-18 X 1/2 SOCKET HEAD SCREW
22	1	A2120	CONTROL VALVE FILTER
23	1	A2119	CONTROL VALVE FILTER NUT
24	2	VT25-20SH500	1/4-20 X 1/2 SOCKET HEAD SCREW
25	4	A2037	MOUNTING FOOT - MACHINED
26	1	A2191	PULL PIN SUBASSEMBLY

ID	QTY	PART #	DESCRIPTION
27	1	VT25-20FH500	1/4-20 X 1/2 FLAT HEAD CAP SCREW
28	1	A2158	CONTROL VALVE HANDLE
29	1	VO-014	O-RING-014
30	1	A2157	NAME LABEL
31	1	A2148	LID
32	1	VO-167	O-RING 167
33	1	A2146	UPPER TRUNNION - HARDCOAT
34	2	VM4195	SPRING HELICAL COMPRESSION
35	2	V2120-TORLON	3/16" BALL
36	1	A2145	CONTROL VALVE SHORT SHAFT
37	2	VO-190	O-RING-190
38	1	VFSP2M-SS	1/4"NPT PLUG - HEX SOCKET
39	1	AY175	200 PSI GAUGE
40	1	X165	SPRING
41	1	AY170	GAUGE PROTECTOR
42	1	VFHB4MX2F	BUSHING
43	2	VO-150	O-RING-150
44	1	A2155	PRV PLUG
45	1	A1755	PRESSURE RELIEF VALVE
46	2	VT37-16SH875	3/8-16 X 7/8 SOCKET HEAD SCREW
47	1	A2149	HANDLE MOUNT
48	1	X362	PEG
49	4	AY360NJ	SIDE B ADAPTER 2 1/2 NH
50	4	AY928	2.5" HALF BALL VALVE PARTS SET
51	1	AY315	VALVE SEAT
52	6	VT25-20SS625	1/4-20 X 5/8 SOCKET SET SCREW

## 6.3 INLET COMPONENTS PARTS LIST

ID	QTY	DESCRIPTION	4.0" STORZ	5.0" STORZ	6.0" STORZ	4.0" FEMALE	4.5" FEMALE	5.0" FEMALE
2	1	INLET MATE	A2115	A2115	A2115	A2115	A2116	A2116
	1	GASKET	--	--	--	V3198	V3210	V3220
	1	INLET COUPLING	A4124	A4125	A4126	A4562N	A4568NR	A4573NT
	1	PLASTIC STRIP	A1292	A1291	A1291	A1291	A1293	A1293
	1	CUP SEAL	A1597	A1596	A1596	--	--	--
	1	LOCKOUT SCREW	A1294	A1294	A1294	--	--	--
	1	NFS RING	--	--	--	A4561	--	--
	1	O-RING	--	--	--	VO-248	--	--
	1	MATE PSM4.25 X PSF5.25	A4730	--	--	--	--	--
	1	CUP SEAL	A1596	--	--	--	--	--
	1	PORT COVER	A1298	--	--	--	--	--
	1	PLASTIC STRIP	A1291	--	--	--	--	--

## 6.4 OUTLET COMPONENTS PARTS LIST

ID	QTY	DESCRIPTION	4.0" STORZ	5.0" STORZ	6.0" STORZ	4.0" MALE	4.5" MALE	5.0" MALE
2	1	OUTLET MATE	A2115	A2115	A2115	A2115	A2115	A2115
	1	CUP SEAL	A1597	A1596	A1596	A1596	A1596	A1596
	1	PLASTIC STRIP	A1292	A1291	A1291	A1291	A1291	A1291
	1	LOCKOUT SCREW	A1294	A1294	A1294	A1294	A1294	A1294
	1	OUTLET COUPLING	A4124	A4125	A4126	A4620N	A4625N	A4630N
	1	PORT COVER	A1298	--	--	--	--	--
	1	MATE PSM4.25 X PSF5.25	A4730	--	--	--	--	--
	1	CUP SEAL	A1596	--	--	--	--	--
	1	PLASTIC STRIP	A1291	--	--	--	--	--

## 6.5 PRESSURE RELIEF VALVE COMPONENTS PARTS LIST

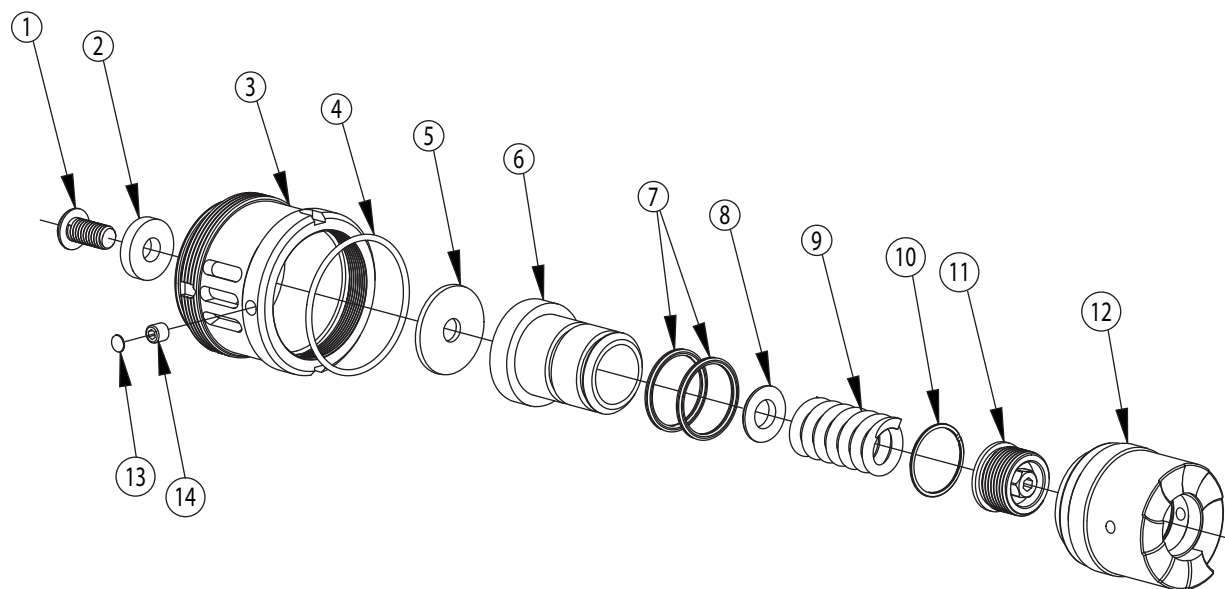

ITEM	QTY	PART #	DESCRIPTION
1	1	VT50-13BH1.0	1/2-13 X 1.0 SCREW
2	1	A1169	DEBRIS WASHER
3	1	A2156	TURND HOUSING
4	1	VO-232	O-RING-232
5	1	A1168	VALVE SEAT PRV
6	1	A1160	PISTON
7	2	VOQ-4222	QUAD-RING 222
8	1	A1166	SPRING SEAT
9	1	A1170	RELIEF SPRING
10	1	V4210	SMALLEY RING
11	1	A1167	ADJUSTING SCREW
12	1	A1164	SPRING HOUSING 200 MAX
13	1	A1162	SET SCREW PLUG
14	1	VT31-18SS250	5/16-18 X 1/4 SET SCREW

## 6.6 SIDE DISCHARGE VALVE COMPONENTS PARTS LIST

ID	QTY	PART #	DESCRIPTION
1	1	AY342-*	HANDLE LABEL
2	1	AY340	VALVE HANDLE
3	1	AY345	HANDLE PIVOT PIN
4	2	VT25-20BH750	1/4-20 X 3/4 SCREW
5	1	AY354	TRUNNION RETAINER
6	1	VO-033	O-RING-033
7	1	VO-216	VO-216
8	1	AY324	BUSHING
9	2	VO-011	O-RING-011
10	1	AY320	OUTER UPPER TRUNNION
11	1	AY352	FLOATING RING
12	1	AY350	INNER UPPER TRUNNION
13	1	V2125	1/4" SS BALL
14	2	VP312X.50	DOWEL PIN
15	1	HC115	SPRING
16	2	VO-115	O-RING-115
17	1	G636-020	WASHER
18	1	AY325	BELLEVILLE SPRING
19	1	VO-123	O-RING-123
20	1	AY351	INNER BUSHING
21	1	AY310	HALF BALL
22	1	AY357	LOWER TRUNNION

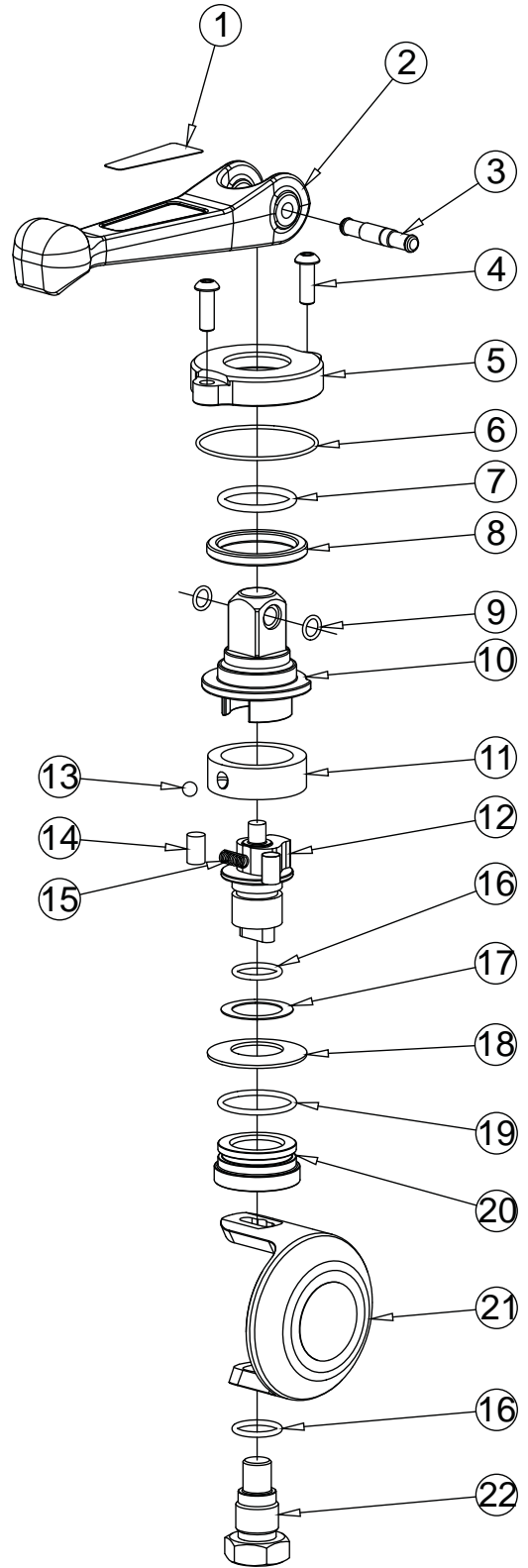

## 7.0 WARRANTY

Task Force Tips, Inc., 3701 Industrial Way, Valparaiso, Indiana 46383-9327 USA (“TFT”) warrants to the original purchaser of its 5-WAY MANIFOLD (“equipment”), and to anyone to whom it is transferred, that the equipment shall be free from defects in material and workmanship during the five (5) year period from the date of purchase.

TFT’s obligation under this warranty is specifically limited to replacing or repairing the equipment (or its parts) which are shown by TFT’s examination to be in a defective condition attributable to TFT. To qualify for this limited warranty, the claimant must return the equipment to TFT, at 3701 Industrial Way, Valparaiso, Indiana 46383-9327 USA, within a reasonable time after discovery of the defect. TFT will examine the equipment. If TFT determines that there is a defect attributable to it, TFT will correct the problem within a reasonable time. If the equipment is covered by this limited warranty, TFT will assume the expenses of repair.

If any defect attributable to TFT under this limited warranty cannot be reasonably cured by repair or replacement, TFT may elect to refund the purchase price of the equipment, less reasonable depreciation, in complete discharge of its obligations under this limited warranty. If TFT makes this election, claimant shall return the equipment to TFT free and clear of any liens and encumbrances.

This is a limited warranty. The original purchaser of the equipment, any person to whom it is transferred, and any person who is an intended or unintended beneficiary of the equipment, shall not be entitled to recover from TFT any consequential or incidental damages for injury to person and/or property resulting from any defective equipment manufactured or assembled by TFT. It is agreed and understood that the price stated for the equipment is in part consideration for limiting TFT’s liability. Some states do not allow the exclusion or limitation of incidental or consequential damages, so the above may not apply to you.

TFT shall have no obligation under this limited warranty if the equipment is, or has been, misused or neglected (including failure to provide reasonable maintenance) or if there have been accidents to the equipment or if it has been repaired or altered by someone else.

THIS IS A LIMITED EXPRESS WARRANTY ONLY. TFT EXPRESSLY DISCLAIMS WITH RESPECT TO THE EQUIPMENT ALL IMPLIED WARRANTIES OF MERCHANTABILITY AND ALL IMPLIED WARRANTIES OF FITNESS FOR A PARTICULAR PURPOSE. THERE IS NO WARRANTY OF ANY NATURE MADE BY TFT BEYOND THAT STATED IN THIS DOCUMENT.

This limited warranty gives you specific legal rights, and you may also have other rights which vary from state to state.

## 8.0 ANSWERS TO YOUR QUESTIONS

We appreciate the opportunity of serving you and making your job easier. If you have any problems or questions, our toll-free “Hydraulics Hotline”, 800-348-2686, is normally available to you 24 hours a day, 7 days a week.