



MANUAL: OASIS HYDRANT ASSIST VALVE

INSTRUCTIONS FOR SAFE OPERATION AND MAINTENANCE

⚠ WARNING

Read instruction manual before use. Operation of this device without understanding the manual and receiving proper training is a misuse of this equipment. A person who has not read and understood all operating and safety instructions is not qualified to operate the Oasis Hydrant Assist Valve. Please call 800-348-2686 with any questions.

⚠ WARNING

This instruction manual is intended to familiarize firefighters and maintenance personnel with the operation, servicing, and safety procedures associated with the Oasis Hydrant Assist Valve.

This manual should be kept available to all operating and maintenance personnel.

OPERATING RANGE:

Pressure Max 250 PSI

Pressure Min 5 PSI

Hydrostatic Proof Test: 900 PSI

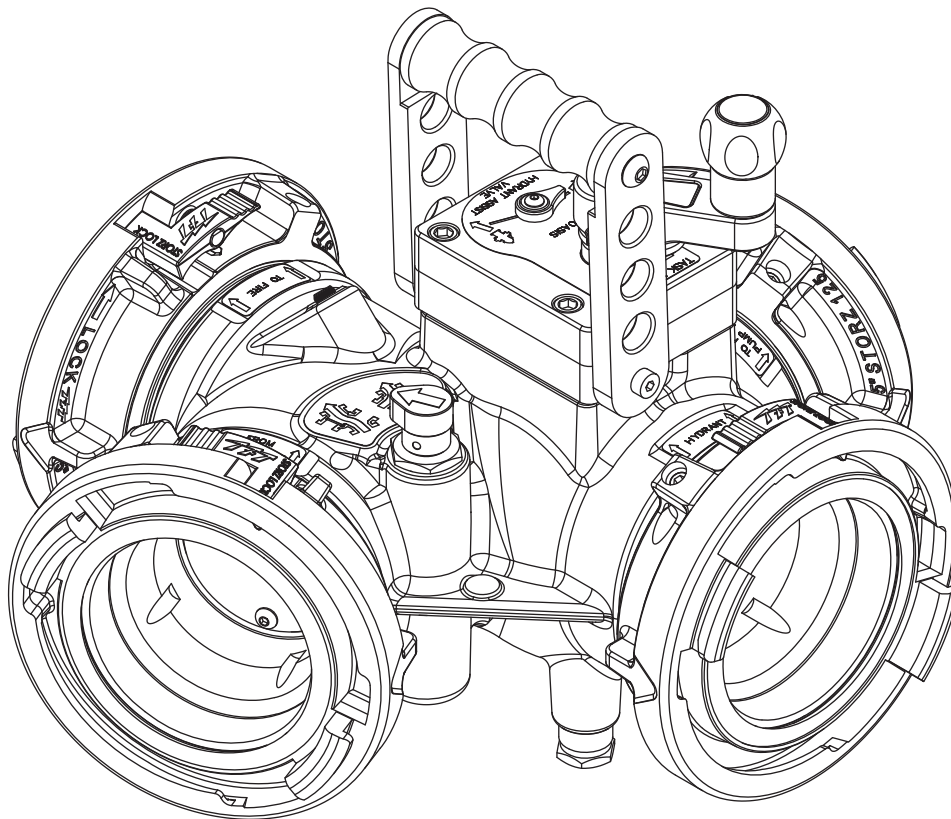

TASK FORCE TIPS, INC.
MADE IN USA • www.tft.com

3701 Innovation Way, Valparaiso, IN 46383-9327 USA
800-348-2686 • 219-462-6161 • Fax 219-464-7155

Table Of Contents

1.0 MEANING OF SAFETY SIGNAL WORDS	3
2.0 SAFETY.....	3
3.0 GENERAL INFORMATION.....	4
3.1 PARTS IDENTIFICATION	
3.2 SPECIFICATIONS	
3.3 CORROSION	
3.4 USE WITH SALT WATER:	
4.0 INSTALLATION.....	5
4.1 CHANGING OFFSET OF CRANK HANDLE	
5.0 USE	5-9
5.1 ATTACH TO A HYDRANT	
5.2 HYDRANT ASSIST OPERATION	
5.3 RELAY OPERATION	
5.4 CLAPPER VALVE POSITION INDICATOR	
5.5 FLOW INCREASE FROM BOOSTING	
5.6 VALVE PRESSURE LOSS	
6.0 MAINTENANCE.....	9
7.0 MODIFICATION PROCEDURE TO ALLOW SHUT-OFF OF THE HYDRANT	10
8.0 EXPLODED VIEWS & PARTS LISTS	11-15
8.1 OASIS HYDRANT ASSIST VALVE	
8.2 INLET/OUTLET OPTIONS	
8.3 CLAPPER	
8.4 PARALLEL DRIVE GEARBOX	
8.0 WARRANTY	16

DANGER

PERSONAL RESPONSIBILITY CODE

The member companies of FEMSA that provide emergency response equipment and services want responders to know and understand the following:

1. Firefighting and Emergency Response are inherently dangerous activities requiring proper training in their hazards and the use of extreme caution at all times.
2. It is your responsibility to read and understand any user's instructions, including purpose and limitations, provided with any piece of equipment you may be called upon to use.
3. It is your responsibility to know that you have been properly trained in Firefighting and /or Emergency Response and in the use, precautions, and care of any equipment you may be called upon to use.
4. It is your responsibility to be in proper physical condition and to maintain the personal skill level required to operate any equipment you may be called upon to use.
5. It is your responsibility to know that your equipment is in operable condition and has been maintained in accordance with the manufacturer's instructions.
6. Failure to follow these guidelines may result in death, burns or other severe injury.

Fire and Emergency Manufacturers and Service Association
P.O. Box 147, Lynnfield, MA 01940 • www.FEMSA.org

1.0 MEANING OF SAFETY SIGNAL WORDS

A safety related message is identified by a safety alert symbol and a signal word to indicate the level of risk involved with a particular hazard. Per ANSI standard Z535.6-2006, the definitions of the four signal words are as follows:



DANGER indicates a hazardous situation which, if not avoided, will result in death or serious injury.



WARNING indicates a hazardous situation which, if not avoided, could result in death or serious injury.



CAUTION indicates a potentially hazardous situation which, if not avoided, may result in minor or moderate injury.



NOTICE is used to address practices not related to personal injury.

2.0 SAFETY



Quick changes in valve position can cause high pressure spikes due to water hammer and may result in damaged equipment which could lead to injury or death. Open and close the valve slowly to avoid water hammer.



Injury or death may occur by attempting to use a damaged valve. Per NPFA 1962, the device shall be inspected and tested at least quarterly. Before use, inspect for damage resulting from:

- Failure to drain valve followed by exposure to freezing conditions
- Exposure to temperatures in excess of 160 degrees F
- Missing parts, physical abuse



This equipment is intended for use by trained personnel for firefighting. Its use for other purposes may involve hazards not addressed by this manual. Seek appropriate guidance and training to reduce risk of injury.



Kinks in supply hose may reduce water flow and cause injury or death to persons dependant on water flow. Avoid tight bends to minimize risk of hoseline kinks.



The valve may be damaged if frozen while containing significant amounts of water. Such damage may be difficult to detect visually and can lead to possible injury or death. Any time the valve is subject to possible damage due to freezing, it must be hydrostatically tested by qualified personnel before being considered safe for use.



Maximum operating pressure 250 psi (17 bar). Do not exceed 250 psi (17 bar) on either side of the valve.



Valve must be properly connected. Mismatched or damaged connectors may cause leaking or uncoupling under pressure and could cause injury.

3.0 GENERAL INFORMATION

TFT's Oasis Hydrant Assist Valve is a versatile valve that can be used as a hydrant booster, a gated wye, or for inline pumping during relay operations. In hydrant boosting operation, the valve is first connected to the hydrant and to the intake supply line on the first pumper. Inlet and outlet supply lines on a boost pumper are then connected to the valve to draw water directly from the hydrant connection and increase pressure/flow to the first pumper. Inline pumping is achieved in a similar manner. A clapper valve with position indicator provides uninterrupted water flow to the fire when transitioning to boost mode, and in the event of boost pump failure. Two unique valve position indicators tell the operator if the ball and clapper valves are open, closed, or somewhere in between. Designed for use with 3.5", 4", 4.5" or 5" (89, 100, 115 or 125 mm) hose. Stainless steel half ball valve provides corrosion protection. Maximum operating pressure is 250 psi (17 bar). Meets 900 psi (62 bar) hydrostatic strength test. The aluminum casting is hardcoat anodized inside and out, and TFT powder coat finished on the outside.

3.1 PARTS IDENTIFICATION

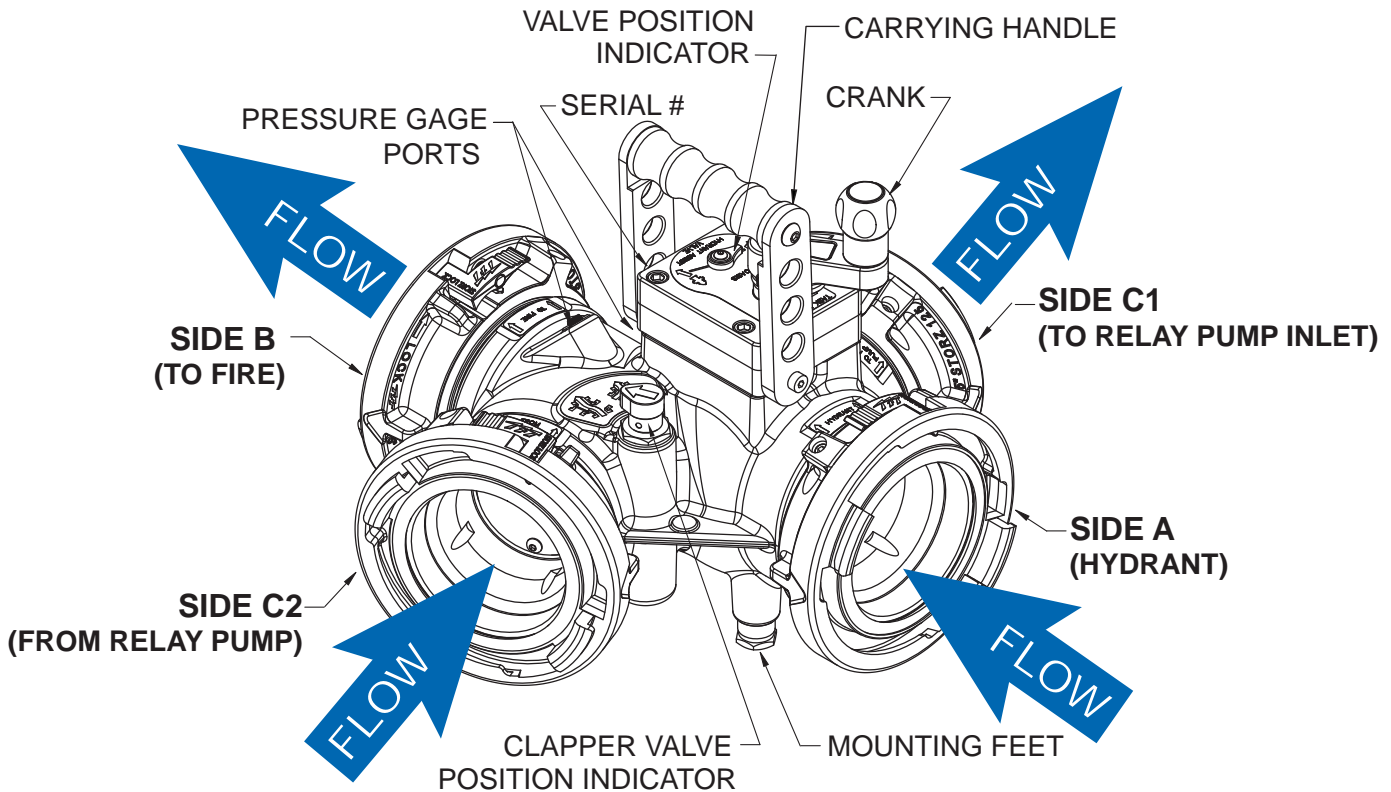

3.2 SPECIFICATIONS

Main waterway size (at valve seat): 3.65" (93mm)

Oasis Hydrant Assist Valve meets NFPA 1965 slow close requirement.

Maximum Operating Pressure: 250 psi (17 bar)

Hydrostatic Proof Test Pressure: 900 psi (62 bar)

Temperature Rating*: -25°F to 135°F (-32°C to 57°C)

*For temperatures below 32°F (0°C), valves must be drained after use to avoid damage.

See section 2.0 SAFTEY.

3.3 CORROSION

Hose couplings are attached using polymer bearing rings which provide electrical insulation to help prevent galvanic corrosion. The parts are hard anodized inside and out, and powder coated on the outside to help prevent corrosion. The effects of corrosion can be minimized by good maintenance practice. See section 6.0 MAINTENANCE.

3.4 USE WITH SALT WATER

Use with salt water is permissible provided valve is thoroughly cleaned with fresh water after each use. The service life of the valve may be shortened due to the effects of corrosion and is not covered under warranty.

4.0 INSTALLATION

Make connections to fire hose or fittings on each side of the Oasis Hydrant Assist Valve

⚠ CAUTION

Dissimilar metals coupled together can cause galvanic corrosion that can result in the inability to unscrew the threads and complete loss of thread engagement over time. Per NFPA 1962 (1998 edition), if dissimilar metals are left coupled together an anti-corrosive lubricant should be applied to the threads. Also, the coupling should be disconnected and inspected at least quarterly.

⚠ CAUTION

Male fire hose threads are sharp and can cause injury. Be careful when around male hose threads.

4.1 CHANGING OFFSET OF CRANK HANDLE

When equipped with a crank handle, two offset positions are available to adjust the swing radius of the crank and knob as shown in the figure below. The longer offset position offers reduced effort to operate the valve. The shorter offset is available to avoid interference with other equipment. To change the offset, remove the two 1/4-20 x 1/2" button head cap screws from crank. Place crank in desired position and replace screws.

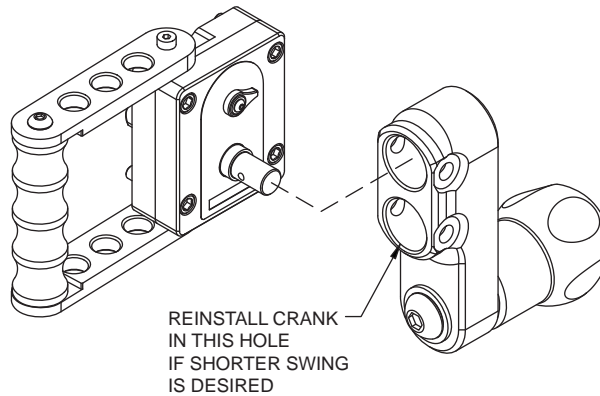

5.0 USE

5.1 ATTACHING TO A HYDRANT

Attaching to a hydrant can be easily accomplished by holding the valve by the handle and allowing it to hang as shown. Tighten coupling when valve is in desired orientation. Fold the handle down.

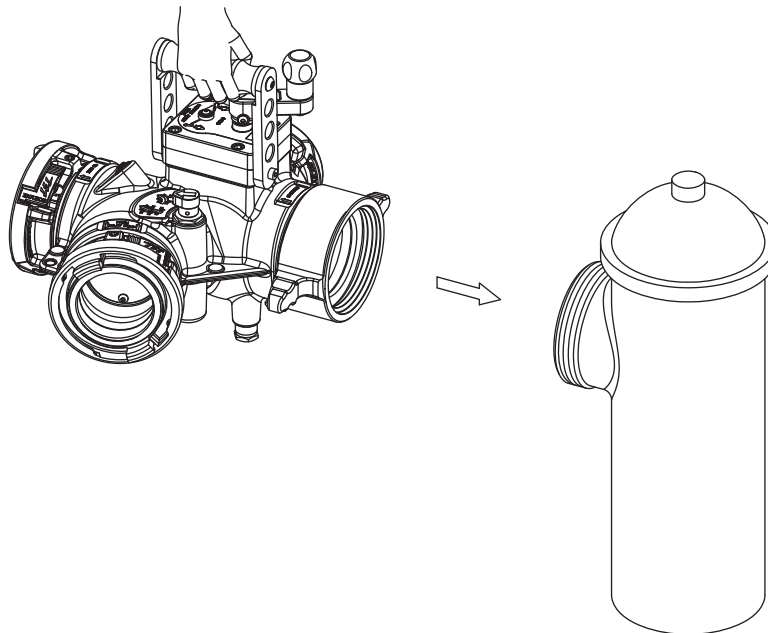

5.2 HYDRANT ASSIST OPERATION

Mode 1:

1. Attach the inlet port marked "Hydrant" either directly to a hydrant, to a supply line connected to a hydrant or to a supply line connected to the discharge of an assist pumper.
2. Attach one end of a supply hose to the port on the valve marked "TO FIRE" and the other end to the intake port of the attack pumper.
3. Rotate the crank on top of the valve counterclockwise until the crank stops.
4. Open hydrant slowly when ready to flow.

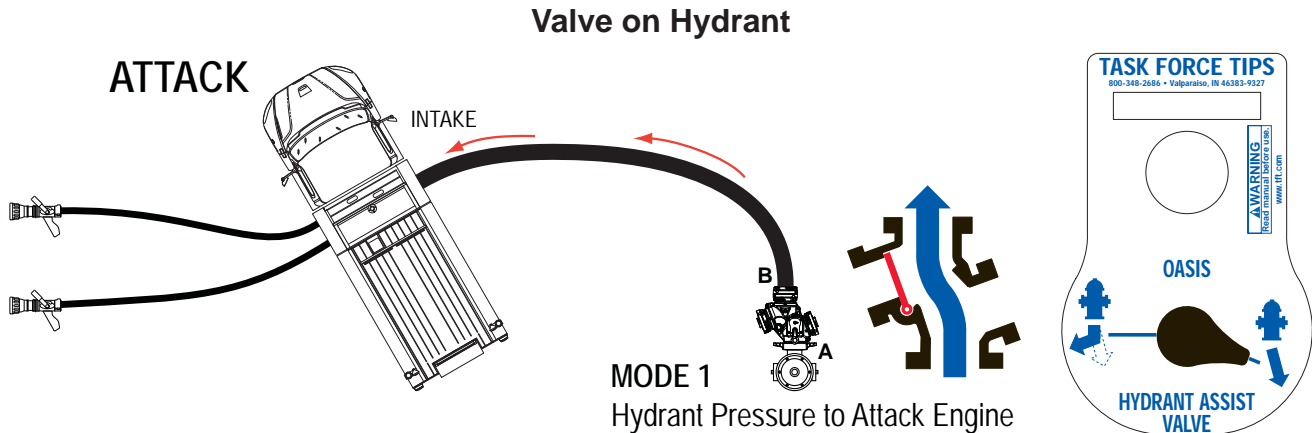

Mode 2 BOOST:

1. Attach valve to hydrant and attack pumper and establish flow per mode 1 instructions
2. Attach one end of a supply hose to the port on the valve marked "TO RELAY PUMP INLET" and the other end to the intake port of the assist pumper.
3. Attach one end of a supply hose to the port on the valve marked "FROM RELAY PUMP" and the other end to the discharge port of the assist pumper.
4. Rotate the crank on top of the valve clockwise until the crank stops and the indicator on the gear box points to Assist mode.

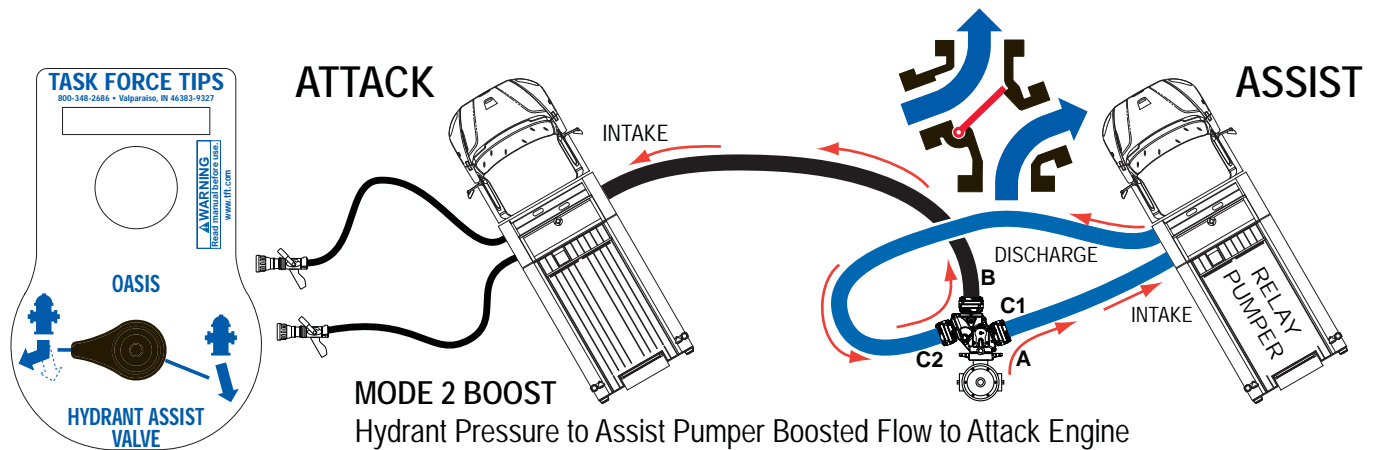

5.3 RELAY OPERATION

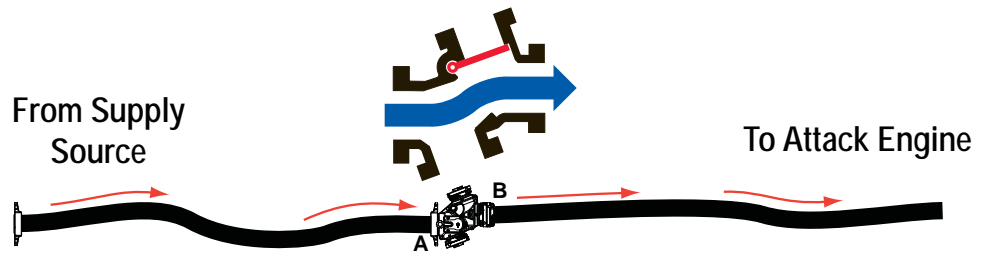
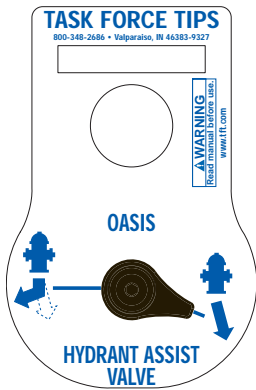

MODE 1
Valve In Street Ready For Relay Operations
Source Pressure to Attack Engine

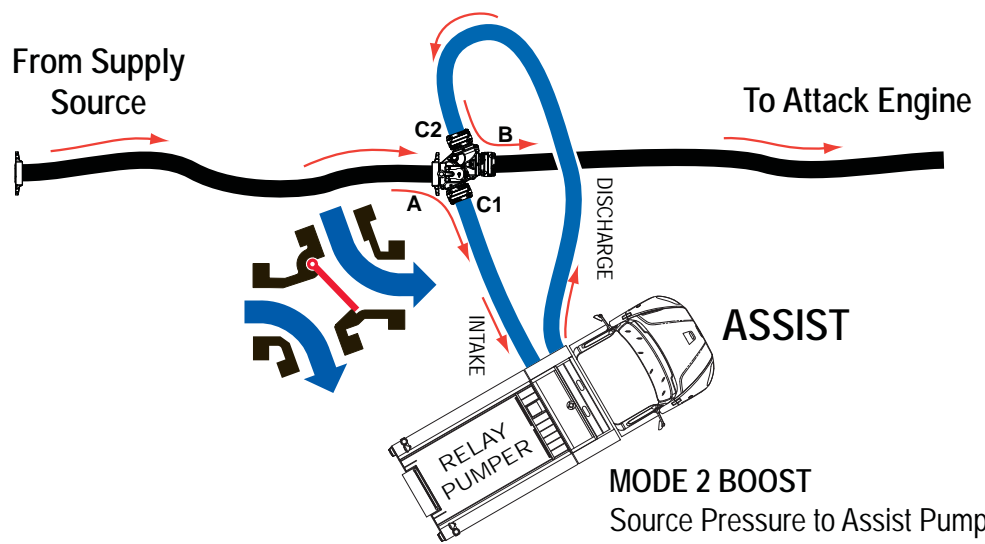
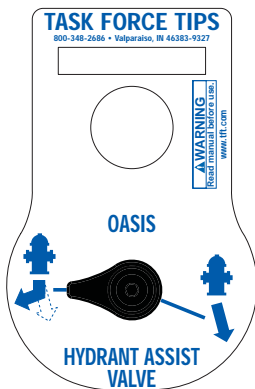

MODE 2 BOOST
Source Pressure to Assist Pumper
Boosted Flow to Attack Engine

5.4 CLAPPER VALVE POSITION INDICATOR

The clapper valve automatically controls whether water is supplied to the attack pumper directly from the hydrant (at hydrant pressure), or from a relaying pumper (at boosted pressure). When water pressure is supplied to the “HYDRANT” port and no boost pressure is being supplied to the “FROM RELAY PUMP” port, the indicator will show the clapper shutting off the “FROM RELAY PUMP” port and allowing water to flow directly from the “HYDRANT” port to the “TO FIRE” port.

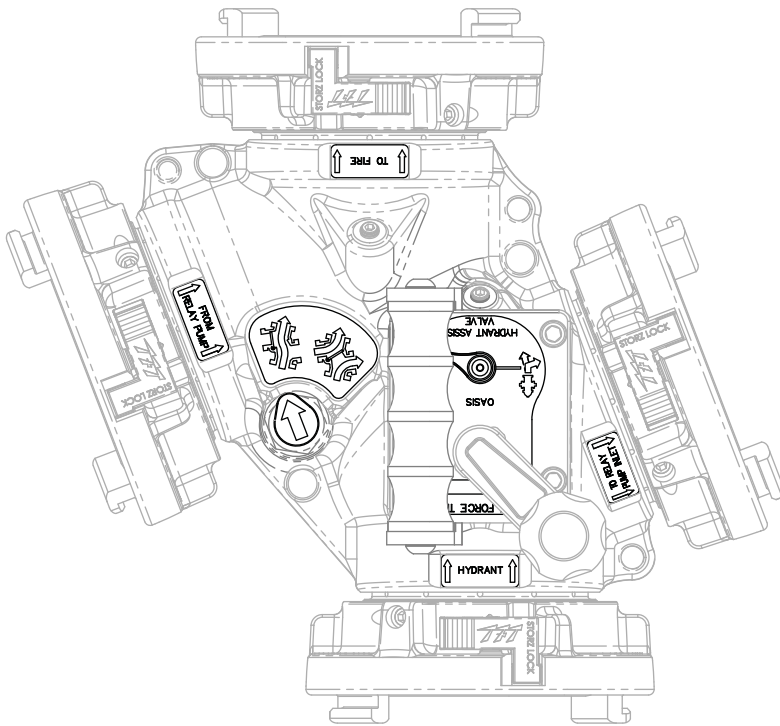

MODE 1

Ball valve indicator showing crank rotated counterclockwise, shutting off “TO RELAY PUMP INLET”. Clapper indicator showing clapper shutting off “FROM PUMP RELAY” port and allowing water to flow directly from the “HYDRANT” port to the “TO FIRE” port.

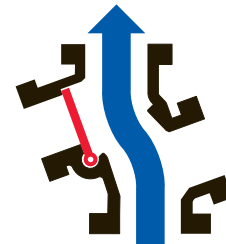

When water is supplied from a relaying pumper to the “FROM RELAY PUMP” port at a pressure in excess of hydrant pressure, the clapper valve closes an inner port that diverts all hydrant water to the assist pumper through the “TO RELAY PUMP INLET” port, and allows water to flow directly from the “FROM RELAY PUMP” port to the “TO FIRE” port at a boosted pressure.

MODE 2 BOOST

Ball valve indicator showing crank rotated clockwise, opening “TO RELAY PUMP INLET”. Clapper indicator showing clapper shutting off inner port and diverting water from “HYDRANT” port to “TO RELAY PUMP INLET” port and allowing water to flow from the “FROM PUMP RELAY” port to the “TO FIRE” port.

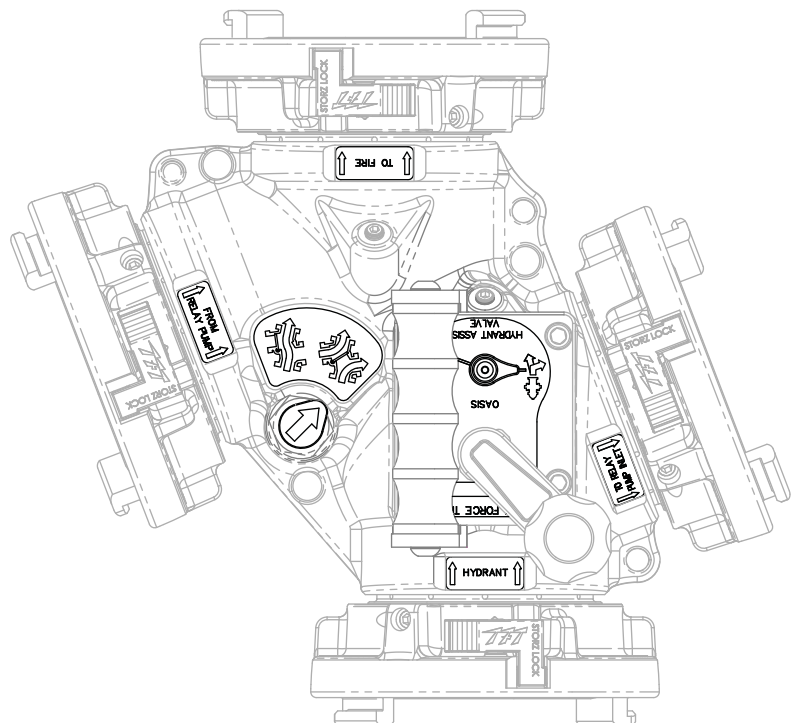
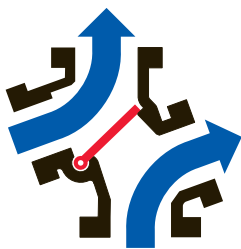

5.5 FLOW INCREASE FROM BOOSTING

			GALLONS OF WATER PER MINUTE FLOWING THROUGH VARIOUS LENGTHS AND SIZES OF HOSE WITH AND WITHOUT PRESSURE ADDED BY BOOST PUMPER					
			4" HOSE			5" HOSE		
			500 ft.	1000 ft.	1500 ft.	500 ft.	1000 ft.	1500 ft.
MODE 1	NOMINAL HYDRANT PRESSURE	60	780	550	450	1240	870	710
MODE 2 BOOST	PRESSURE ADDED BY BOOST PUMPER (TOTAL PRESSURE)	90 (150)	1240	870	710	1960	1380	1120
		140 (200)	1430	1010	820	2240	1580	1290

NOTE: (1) Flow rates calculated assuming that 10 psi residual is remaining at the inlet to the attack pumper.

5.6 VALVE PRESSURE LOSS

OASIS HYDRANT ASSIST VALVE PRESSURE LOSS

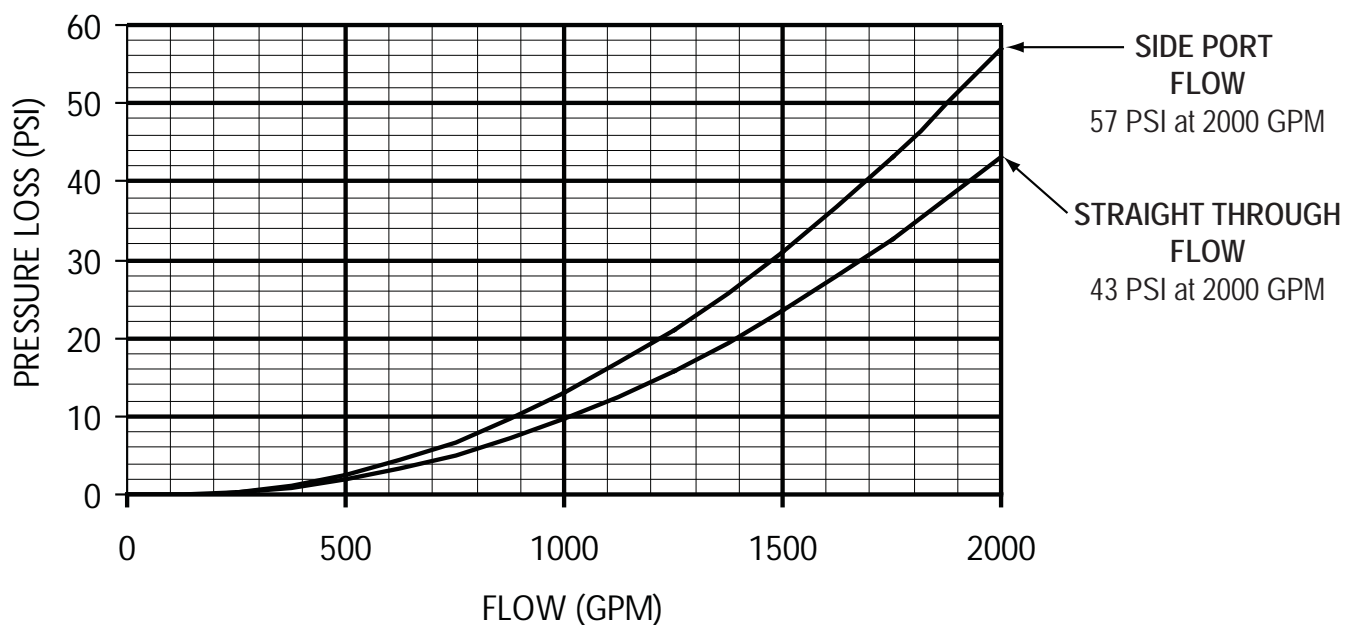

6.0 MAINTENANCE

This valve should be disconnected, cleaned and visually inspected inside and out at least quarterly for proper function per NFPA 1962 section 8.2, or as water quality and use may require. Moving parts such as handles, valve ball and couplings should be checked for smooth and free operation. Seals shall be greased as needed with a silicone-based grease such as Dow Corning 112. Any scrapes that expose bare aluminum should be cleaned and touched up with enamel paint such as Rust-Oleum.

In particular assure that:

- There is no damage such as cracks or dents
- There is no corrosion
- The waterway is clear of obstructions

Replace any missing or damaged parts before returning to service. Any repaired device must be tested before being placed in service.



Any alterations to the device and its markings could diminish safety and constitute a misuse of this product

7.0 MODIFICATION PROCEDURE TO ALLOW SHUT-OFF OF THE HYDRANT

1. Remove (4) bolts holding gearbox in place

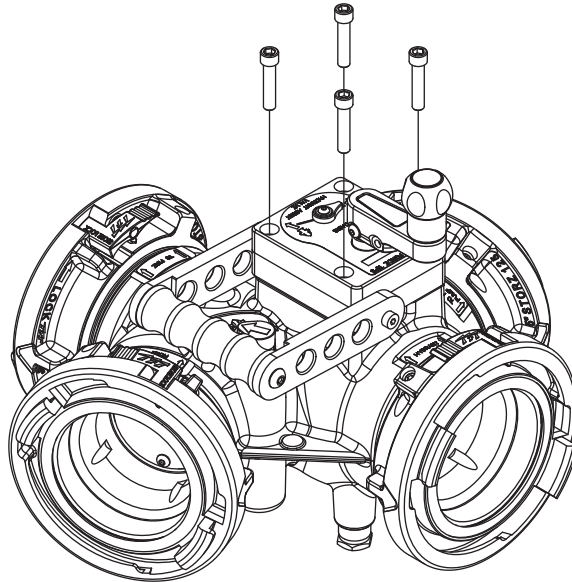

2. Lift gearbox off of unit – note position of valve ball
3. Turn gearbox over and remove bolt that holds the two halves together

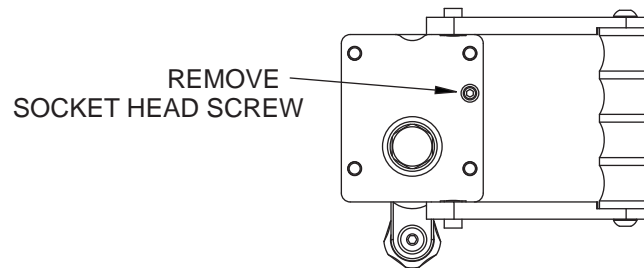

4. Leave top half in this position until reassembly.
5. Turn lower half over. Orientate lower section of gear box as shown. Remove stop pin on LEFT side. **(Do not remove stop pin on right side)**

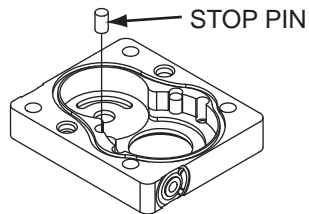

6. Reassemble upper & lower halves of gear box.
7. Ensure that the valve ball has not moved and reinstall gear box.
8. Apply red Loctite® #271 to all 4 screws and reinstall in a chris-cross pattern until all are tight.
9. When valve is in the off position the indicator will point at the word Oasis as shown below.

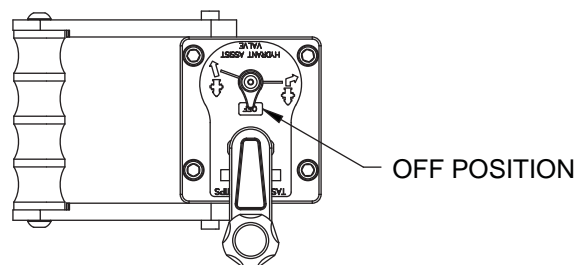

8.0 EXPLODED VIEWS & PARTS LISTS

8.1 OASIS HYDRANT ASSIST VALVE

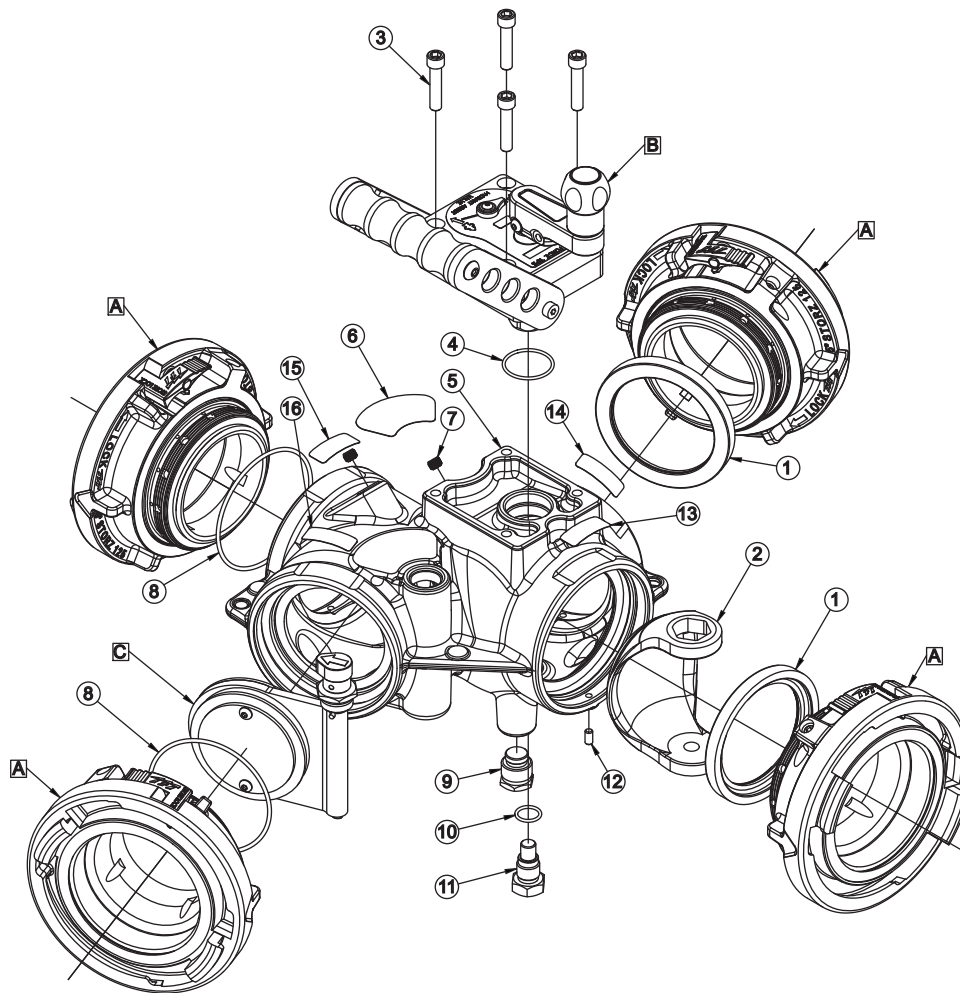

ITEM	DESCRIPTION	QTY	PART #
1	VALVE SEAT BIV	2	A1520
2	HALF BALL STAINLESS STL 5.5"DIA	1	A1043S
3	3/8-16 X 1-3/4 CAP SCREW	4	VT37-16H1.7
4	O-RING-128	1	VO-128
5	RELAY VALVE BODY	1	A2010
6	LABEL: CLAPPER POSITION INDICATOR	1	A2012
7	1/8"NPT PLUG	2	VFSP1M-SS
8	O-RING-243	2	VO-243
9	MOUNTING FOOT	4	A2037
10	O-RING-115	1	VO-115
11	LOWER TRUNNION	1	AY353
12	1/4-20 X 1/2 SET SCREW	4	VT25-20SS500
13	PORT LABEL: HYDRANT	1	A2040
14	PORT LABEL: TO RELAY PUMP INLET	1	A2041
15	PORT LABEL: TO FIRE	1	A2038
16	PORT LABEL: FROM RELAY PUMP	1	A2039
17	CIRCLE COTTER	2	U182
18	CARRYING STRAP	1	A2013
A	COUPLINGS	1	SEE SECTION 7.2
B	PARALLEL SHAFT GEARBOX SUBASSEMBLY	1	SEE SECTION 7.3
C	CLAPPER	1	SEE SECTION 7.4

8.2 INLET/OUTLET OPTIONS

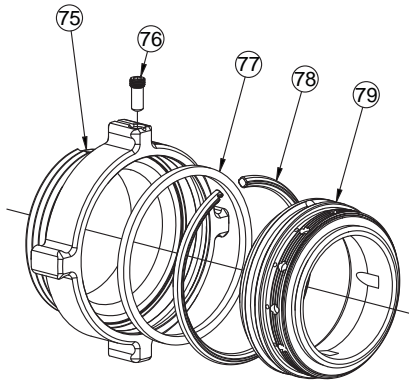

MALE HOSE THREADS					
ITEM	DESCRIPTION	3.5"	4.0"	4.5"	5.0"
75	SPOUT	A4615	A4620N	A4625N	A4630N
76	LOCK-OUT SCREW	A1294	A1294	A1294	A1294
77	CUP SEAL LOADED	A1597	A1596	A1596	A1596
78	PLASTIC STRIP	A1292	A1291	A1291	A1291
79	MATE	A2015	A2016	A2016	A2016

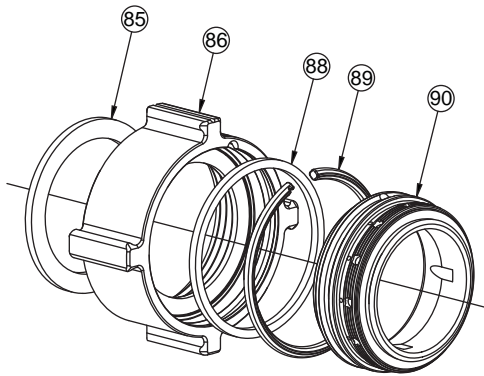

FEMALE HOSE THREADS ROCKER LUGS - FTS					
ITEM	DESCRIPTION	3.5"	4.0"	4.5"	5.0"
85	GASKET	V3196	V1398	V3210	V3220
86	COUPLING	A4655N	A4660N	A4665N	A4670N
88	CUP SEAL	A1597	A1596	A1596	A1596
89	PLASTIC STRIP	A1292	A1291	A1291	A1291
90	MATE	A2015	A2016	A2016	A2016

FEMALE HOSE THREADS ROCKER LUGS - FREE SPINNING				
ITEM	DESCRIPTION	4.0"	4.5"	5.0"
85	GASKET	V1398	V3210	V3220
86	COUPLING	A4663NP	A4668NR	A4673NT
89	PLASTIC STRIP	A1291	A1293	A1293
90	MATE	A2017	A2019	A2019
FREE SPINNING COUPLINGS DO NOT USE CUP SEALS				

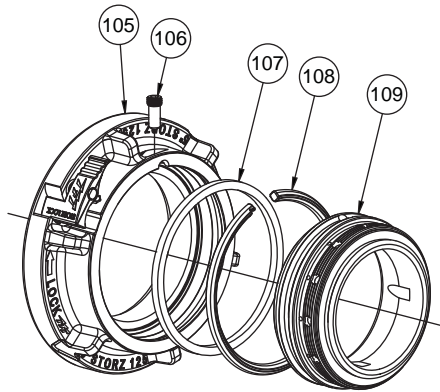

STORZ COUPLINGS			
ITEM	DESCRIPTION	4.0"	5.0"
105	STORZ SUBASSEMBLY	A4124	A4125
106	LOCK-OUT SCREW	A1294	A1294
107	CUP SEAL LOADED	A1597	A1596
108	PLASTIC STRIP	A1292	A1291
109	MATE	A2015	A2016

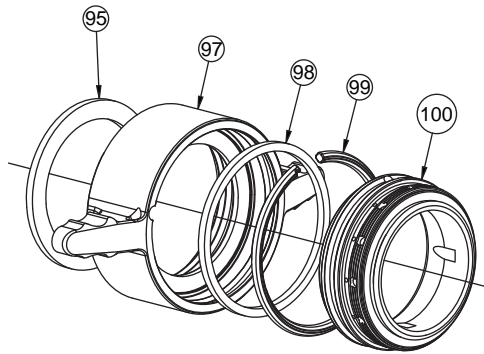

FEMALE HOSE THREADS LONG HANDLES - FTS			
ITEM	DESCRIPTION	4.0"	5.0"
95	GASKET	V3198	V3210
97	COUPLING	A4560N	A4565N
98	CUP SEAL	A1596	A1596
99	PLASTIC STRIP	A1291	A1291
100	MATE	A2016	A2016

FEMALE HOSE THREADS LONG HANDLES - FREE SPINNING				
ITEM	DESCRIPTION	4.0"	4.5"	5.0"
95	GASKET	V3198	V3210	V3220
97	COUPLING	A4555NP	A4568NR	A4573NT
99	PLASTIC STRIP	A1291	A1293	A1293
100	MATE	A2017	A2019	A2019

FREE SPINNING COUPLINGS DO NOT USE CUP SEALS

7.3 CLAPPER

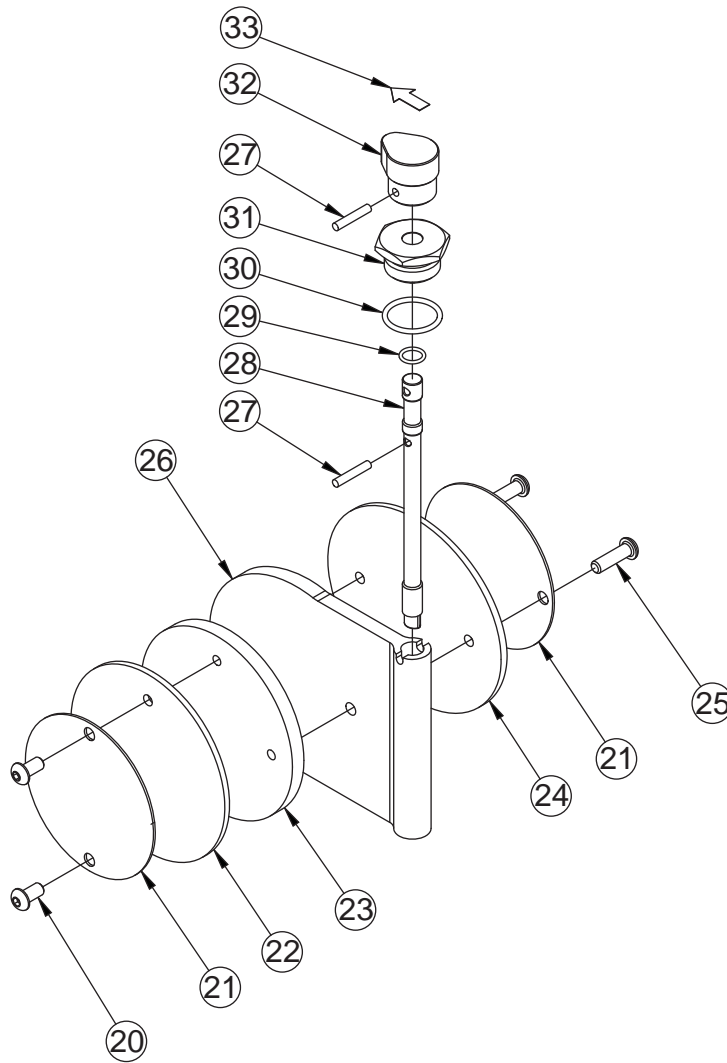

ITEM	DESCRIPTION	QTY	PART #
20	1/4-20 X 1/2 SET SCREW	2	VT25-20BH500
21	WASHER	2	A2033
22	OUTER CLAPPER SEAL	1	A2032
23	SPACER PLATE	1	A2036
24	INNER CLAPPER SEAL	1	A2031
25	1/4-20 X 7/8 SET SCREW	2	VT25-20BH875
26	CLAPPER	1	A2034
27	5/32 X 7/8 HDP SPIROL PIN	2	V1900
28	PIVOT PIN	1	A2035
29	O-RING-012	1	VO-012
30	O-RING-119	1	VO-119
31	PIVOT CAP	1	G191
32	LOCATOR	1	A5774
33	ARROW LABEL	1	UL220

7.4 PARALLEL DRIVE GEARBOX

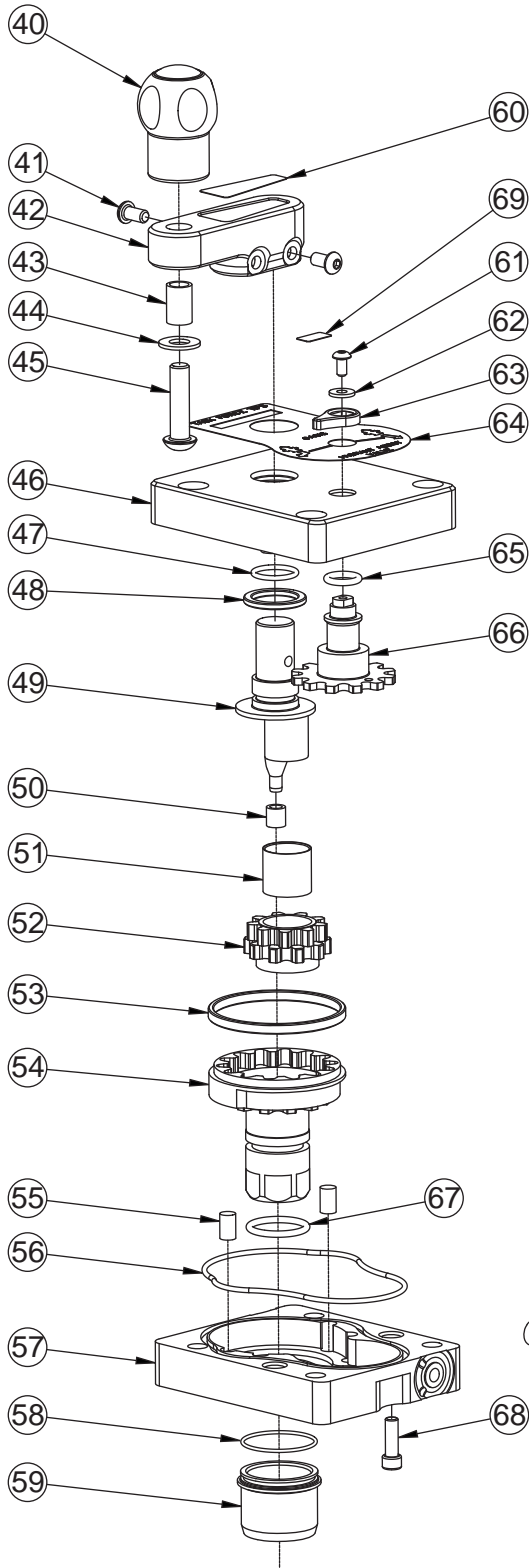

A1633 PARALLEL DRIVE GEARBOX SUBASSEMBLY			
ITEM	DESCRIPTION	QTY	PART #
40	KNOB	1	A1512
41	1/4-20 X 1/2 SCREW	2	VT25-20BH500
42	CRANK	1	A1559
43	CRANK BUSHING	1	A1513
44	WASHER	1	VW812X406-65
45	3/8-16 X 1-1/2 SCREW	1	VT37-16BH1.5
46	GEARBOX	1	A1550
47	O-RING-116	1	VO-116
48	SPACER	1	A1556
49	DRIVE SHAFT	1	A1555
50	NYLON BUSHING	1	AY307
51	GEAR BUSHING	1	A1548
52	DOUBLE GEAR	1	A1554
53	TRUNNION BUSHING	1	A1549
54	INNER TRUNNION	1	A1553
55	DOWEL PIN	2	VP312X.50
56	O-RING-154	1	VO-154
57	SUBPLATE	1	A1551
58	O-RING-028	1	VO-028
59	INNER BUSHING	1	A1552
60	HANDLE LABEL - BLUE	1	AY342-BLU
	HANDLE LABEL - RED		AY342-RED
	HANDLE LABEL - WHITE		AY342-WHT
61	10-24 3/8 SCREW	1	VT10-24BH375
62	WASHER	1	VW500X203-60
63	POSITION INDICATOR	1	A1558
64	GEARBOX LABEL	1	A2011
65	O-RING 206	1	VO-206
66	INDICATOR GEAR	1	A1557
67	O-RING 214	1	VO-214
68	1/4-20 X 3/4 SCREW	1	VT25-20SH750
69	OFF LABEL	1	A2042
70	HANDLE TOP	1	XX625
71	SIDE HANDLE	2	A1562
72	3/8-16 X 1 BUTTON HEAD SCREW	2	VT37-16BH1.0
73	5/16-18 X 1/2 SOCKET HEAD SHOULDER BOLT	2	VT31-18SB500
74	DETENT SPRING	2	HM770
75	.243" TORLON BALL	2	VB243TO

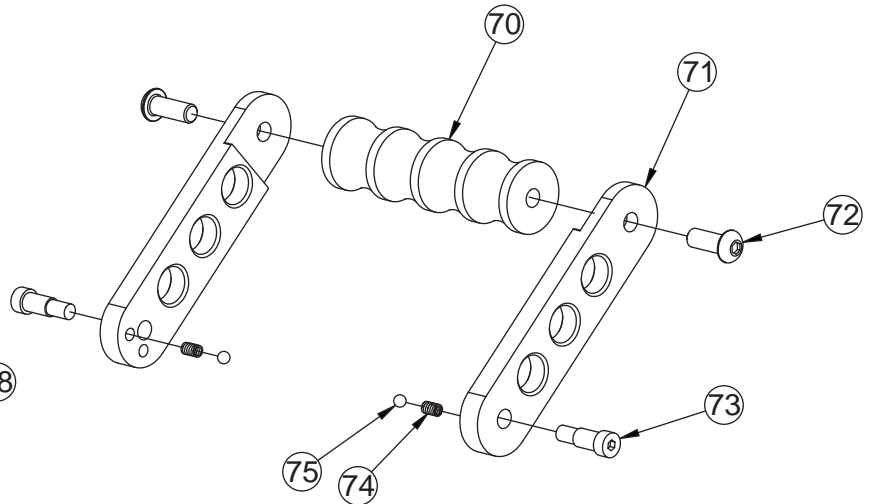

8.0 WARRANTY

Task Force Tips, Inc., 3701 Innovation Way, Valparaiso, IN 46383-9327 (*TFT*) warrants to the original purchaser of its Oasis Valve (*equipment*), and to anyone to whom it is transferred, that the equipment shall be free from defects in material and workmanship during the five (5) year period from the date of purchase.

TFT's obligation under this warranty is specifically limited to replacing or repairing the equipment (or its parts) which are shown by TFT's examination to be in a defective condition attributable to TFT. To qualify for this limited warranty, the claimant must return the equipment to TFT, at 3701 Innovation Way, Valparaiso, IN 46383-9327, within a reasonable time after discovery of the defect. TFT will examine the equipment. If TFT determines that there is a defect attributable to it, TFT will correct the problem within a reasonable time. If the equipment is covered by this limited warranty, TFT will assume the expenses of repair.

If any defect attributable to TFT under this limited warranty cannot be reasonably cured by repair or replacement, TFT may elect to refund the purchase price of the equipment, less reasonable depreciation, in complete discharge of its obligations under this limited warranty. If TFT makes this election, claimant shall return the equipment to TFT free and clear of any liens and encumbrances.

This is a limited warranty. The original purchaser of the equipment, any person to whom it is transferred, and any person who is an intended or unintended beneficiary of the equipment, shall not be entitled to recover from TFT any consequential or incidental damages for injury to person and/or property resulting from any defective equipment manufactured or assembled by TFT. It is agreed and understood that the price stated for the equipment is in part consideration for limiting TFT's liability. Some states do not allow the exclusion or limitation of incidental or consequential damages, so the above may not apply to you.

TFT shall have no obligation under this warranty if the equipment is, or has been, misused or neglected (including failure to provide reasonable maintenance) or if there have been accidents to the equipment or if it has been repaired or altered by someone else.

THIS IS A LIMITED EXPRESS WARRANTY ONLY. TFT EXPRESSLY DISCLAIMS WITH RESPECT TO THE EQUIPMENT ALL IMPLIED WARRANTIES OF MERCHANTABILITY AND ALL IMPLIED WARRANTIES OF FITNESS FOR A PARTICULAR PURPOSE. THERE IS NO WARRANTY OF ANY NATURE MADE BY TFT BEYOND THAT STATED IN THIS DOCUMENT.

This limited warranty gives you specific legal rights, and you may also have other rights which vary from state to state.