



MANUAL: Valve Under Monitor (VUM) Valve Under Monitor Remote Control (VUM RC)

INSTRUCTIONS FOR INSTALLATION, SAFE OPERATION AND MAINTENANCE

WARNING

Read instruction manual before use. Operation of this device without understanding the manual and receiving proper training is a misuse of this equipment. A person who has not read and understood all operating and safety instructions is not qualified to operate the Valve Under Monitor or Valve Under Monitor RC.

This instruction manual is intended to familiarize firefighters and maintenance personnel with the operation, servicing and safety procedures associated with the Valve Under Monitor or Valve Under Monitor RC.

This manual should be kept available to all operating and maintenance personnel.

SAFE OPERATING RANGE:

Up to 2000 gpm below 200 psi *
(8000 l/min @ 14bar)

Up to 1500 gpm @ 300 psi maximum*
(6000 l/min @ 21 bar)

Six seconds from open to close

Meets NFPA 1901 slow close requirement

Hydrostatic Proof Test:

900 psi (62bar)

SAMPLE CONFIGURATIONS

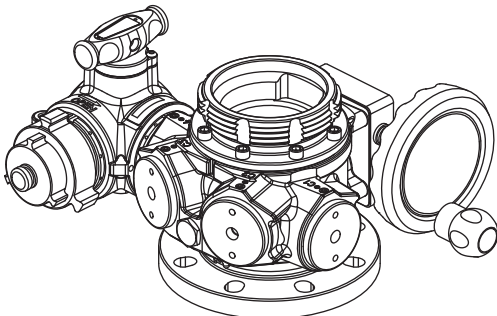

VUM with 4.5" Quick Connect
and 2.5" Gated Elbow
AKM1Q1113D

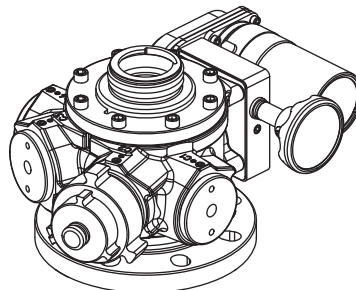

VUM RC with 2.5" Quick Connect
and 2.5" Hose Thread Port
AKE1T1511D

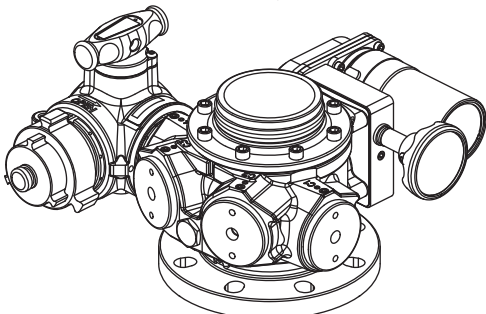

VUM RC with CODE-RPM outlet
and 2.5" Gated Elbow
AKE111113D

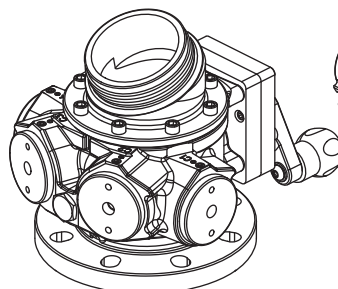

VUM with 22.5° CODE-RPM outlet
and Parallel Shaft Gearbox
AKP121111D

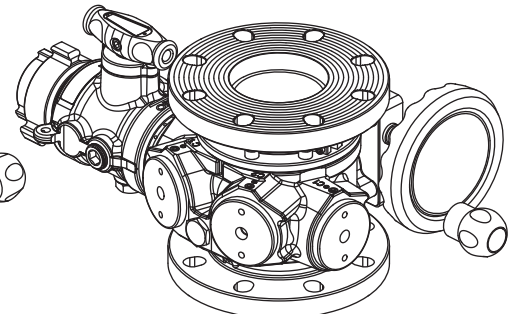

VUM with 4" ANSI 150 outlet
and 2.5" Straight Valve
AKM131114D

* valid for monitor outlets up to 16" (400mm) tall from the VUM outlet. Read section 4.3 for details.

TASK FORCE TIPS, INC.
MADE IN USA • www.tft.com

3701 Innovation Way, Valparaiso, IN 46383-9327 USA
800-348-2686 • 219-462-6161 • Fax 219-464-7155

▲ DANGER

PERSONAL RESPONSIBILITY CODE

The member companies of FEMSA that provide emergency response equipment and services want responders to know and understand the following:

1. Firefighting and Emergency Response are inherently dangerous activities requiring proper training in their hazards and the use of extreme caution at all times.
2. It is your responsibility to read and understand any user's instructions, including purpose and limitations, provided with any piece of equipment you may be called upon to use.
3. It is your responsibility to know that you have been properly trained in Firefighting and /or Emergency Response and in the use, precautions, and care of any equipment you may be called upon to use.
4. It is your responsibility to be in proper physical condition and to maintain the personal skill level required to operate any equipment you may be called upon to use.
5. It is your responsibility to know that your equipment is in operable condition and has been maintained in accordance with the manufacturer's instructions.
6. Failure to follow these guidelines may result in death, burns or other severe injury.



Fire and Emergency Manufacturers and Service Association
P.O. Box 147, Lynnfield, MA 01940 • www.FEMSA.org

Table Of Contents

1.0 MEANING OF SIGNAL WORDS	4
2.0 SAFETY.....	4
3.0 GENERAL INFORMATION.....	5
3.1 SPECIFICATIONS	5
3.2 PARTS IDENTIFICATION AND MODELS	5
3.3 OVERALL DIMENSIONS AND WEIGHTS.....	8
3.4 AUXILIARY PORT OPTIONS, DIMENSIONS AND WEIGHTS	11
3.5 CORROSION.....	14
3.6 USE WITH SALT WATER	14
4.0 INSTALLATION	14
4.1 DIRECTION OF FLOW.....	14
4.2 STRUCTURAL REQUIREMENTS FOR MONITOR MOUNTING.....	14
4.3 MONITOR INSTALLATION.....	14
4.4 ELECTRICAL INSTALLATION AND WIRING	18
4.5 ELECTRICAL TESTING	18
4.6 INPUT AND SIGNAL CONFIGURATION	19
4.7 VALVE POSITION FEEDBACK RELAYS	19
4.8 AUX BUTTON OPERATION	20
4.9 CHANGING HANDWHEEL OR CRANK TO RIGHT SIDE – MANUAL MODELS	20
4.10 CHANGING HANDWHEEL OR CRANK TO RIGHT SIDE – RC MODELS	21
4.11 SHAFT EXTENSION FOR HANDWHEEL OR CRANK HANDLE.....	21
4.12 CHANGING OFFSET OF CRANK HANDLE	21
4.13 ALUMINUM HANDLE KITS FOR 2.5" GATED ELBOWS AND STRAIGHT HYDRANT VALVES	22
5.0 USE	22
5.1 VALVE POSITION INDICATOR	22
5.2 ELECTRIC REMOTE CONTROL - MANUAL OVERRIDE.....	22
5.3 ELECTRIC REMOTE CONTROL OPERATION	23
6.0 AUTOMATIC WATER DRAIN VALVE	23
7.0 DRAWINGS AND PARTS LISTS.....	24
8.0 TROUBLE SHOOTING	29
9.0 MAINTENANCE	29
10.0 PRESSURE LOSS.....	30
11.0 TEMPLATES.....	31
12.0 WARRANTY	32

1.0 MEANING OF SAFETY SIGNAL WORDS

A safety related message is identified by a safety alert symbol and a signal word to indicate the level of risk involved with a particular hazard. Per ANSI standard Z535.4-2007, the definitions of the four signal words are as follows:



DANGER indicates a hazardous situation which, if not avoided, will result in death or serious injury.



WARNING indicates a hazardous situation which, if not avoided, could result in death or serious injury.



CAUTION indicates a potentially hazardous situation which, if not avoided, may result in minor or moderate injury.

2.0 SAFETY



Do not use AC current to operate the Valve Under Monitor RC. The Valve Under Monitor RC is 12 or 24VDC systems **ONLY!** Using the wrong power source could cause electrocution, resulting in death or serious injury.



Injury or death may occur by attempting to use a damaged Valve Under Monitor or Valve Under Monitor RC. Before using the valve inspect it for damage resulting from:

- Exposure to temperatures in excess of 160 degrees F
- Missing parts, physical abuse
- Failure to drain valve followed by exposure to freezing conditions. Draining can be performed using the automatic drain valve option. See section 6.0 for instructions.



This equipment is intended for use by trained personnel for firefighting. Its use for other purposes may involve hazards not addressed by this manual. See appropriate guidance and training to reduce risk of injury.



Injury or death can result from interrupting flow to nozzles. Avoid situations that may interrupt flow such as: hose line kinks, traffic running over hose, and automatic doors or devices that can pinch the hose.



Injury or death can result from burst hoses and fittings. The Valve Under Monitor does not include a pressure relief valve. Be sure that hose pressures will not exceed the manufacturer's specifications.



Maximum operating pressure 300 PSI (20 bar). Do not exceed 300 PSI on either side of the valve.



Valve must be properly connected. Mismatched or damaged connectors may cause leaking or uncoupling under pressure and could cause injury.



The Valve Under Monitor RC may be remotely operated. The electric drives are current limited but may still produce enough force to cause injury. Keep hands and fingers away from pinch points on the valve.



Do not use the manual override hand wheel while the electric controls are in operation. The electric drives produce enough torque to cause injury.



The Valve Under Monitor RC has current limiting capabilities which stop the motor if an obstruction is encountered. The Valve Under Monitor RC must be installed as instructed using the correct controls and electrical boxes. Failure to do so will result in damage to the electric motor and loss of current limiting controls. This may result in injury.

3.0 GENERAL INFORMATION

The Valve Under Monitor (VUM) is a lightweight, low friction-loss valve and manifold for installation directly beneath monitors on ladders and platforms. The VUM combines the robust valve mechanism from the TFT Ball Intake Valve with a 4" ANSI 150 inlet and up to four 2.5" outlets. The 2.5" outlets are available with integrated valves, male hose threads or female pipe threads. When paired with a TFT monitor, the monitor flange is omitted for additional weight savings and ease of maintenance.

An electric remote controlled (RC) model allows the valve to be operated from a remote location or from any TFT RC Monitor Operator Station. A typical installation will consist of the VUM RC and a valve interface box. Motor controls are designed to auto sense 12 VDC or 24 VDC operation. The motor control circuit utilizes a position encoder and current limiting to protect the drive train at the ends of travel. Unit is supplied with 2' of cable & plug on VUM RC and valve interface box is supplied with 10' of cable & mating receptacle so installation effort is minimized. Cable has only four conductors (two for power and two for communications) further easing installation effort.

To complete the installation, the installer will need to mount and wire the valve interface box. The power supply for the VUM RC will need to be connected to a protected circuit from the truck's power distribution center. Refer to the specifications section 3.1 for nominal current draw.

3.1 SPECIFICATIONS

MODEL	VUM	VUM RC (Remote Control)	
Main Waterway Minimum Diameter (at Valve Seat)	3.65" (93mm)	3.65" (93mm)	
Auxiliary 2.5" Port Minimum Diameter	2.25" (57mm) typical 2.0" (50.8mm) for integrated valves	2.25" (57mm) typical 2.0" (50.8mm) for integrated valves	
Max Pressure	300 psi (20 bar)	300 psi (20 bar)	
Max Flow	2000 gpm @ 200 psi (8000 l/min @ 14bar) 1750 gpm @ 250 psi (6600 l/min @ 17 bar)		
Hydrostatic Proof	900 psi (62bar)		
Temperature Rating*	-25° to 135°F (-32° to 57°C)	-25° to 120°F (-32° to 49°C)	
Operating Temperature Range	-30F to +120F (-34C to +49C)		
Opening/Closing Speed	6 sec		
Voltage- Auto Sense	12 or 24 Volt DC		
Motor Current (RC Only)	Nominal*		Limit
	@ 12 VDC	@ 24 VDC	@ 12 VDC @ 24 VDC
	3 amp	1.5 amp	12 amp 6 amp
Recommended Fuse or Circuit Breaker Size	15 amp @ 12 Volt 7.5 amp @ 24 Volt		
Environmental Rating	All components designed to meet minimum rating of NEMA 4 (IP65)		
*for temperatures below 32°F (0°C), VUM and monitor must be drained after use to avoid damage. See section 2.0 SAFETY and section 6.0 AUTOMATIC WATER DRAIN VALVE for instructions.			

3.2 PARTS IDENTIFICATION AND MODELS

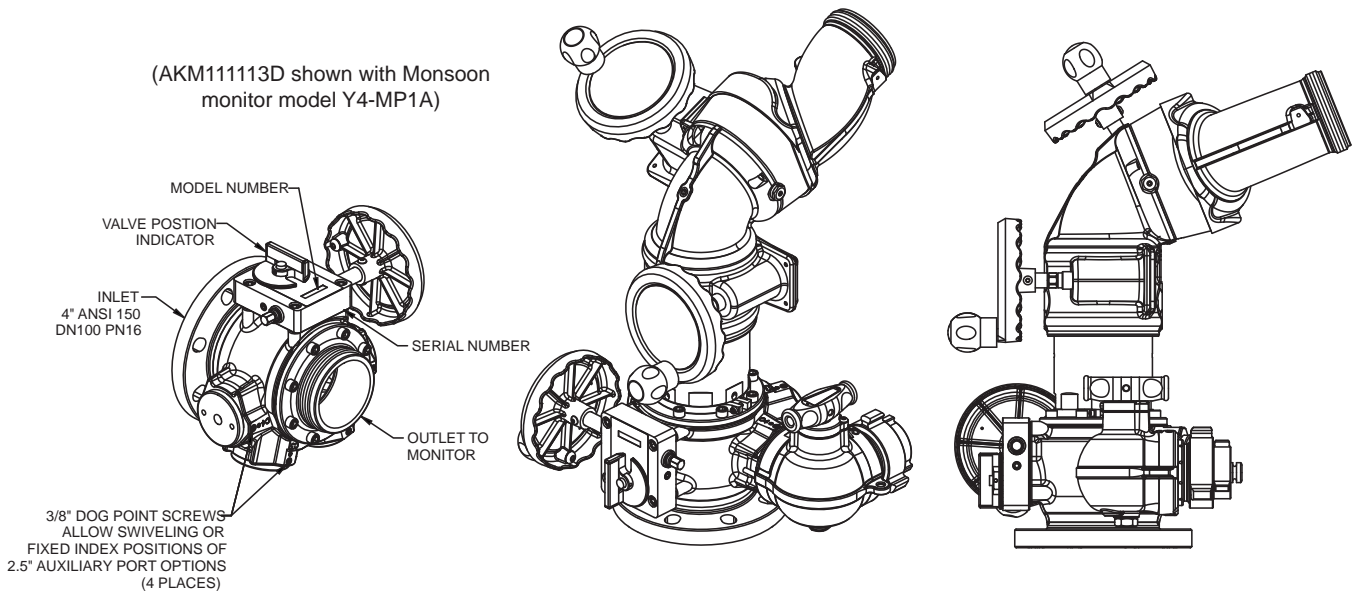

Figure 3.2a
VUM WITH MANUAL HANDWHEEL CONTROL (WORM DRIVE GEARBOX)

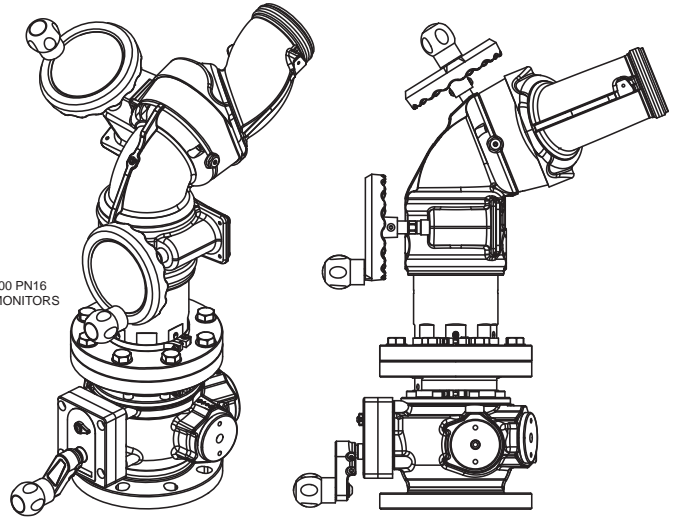
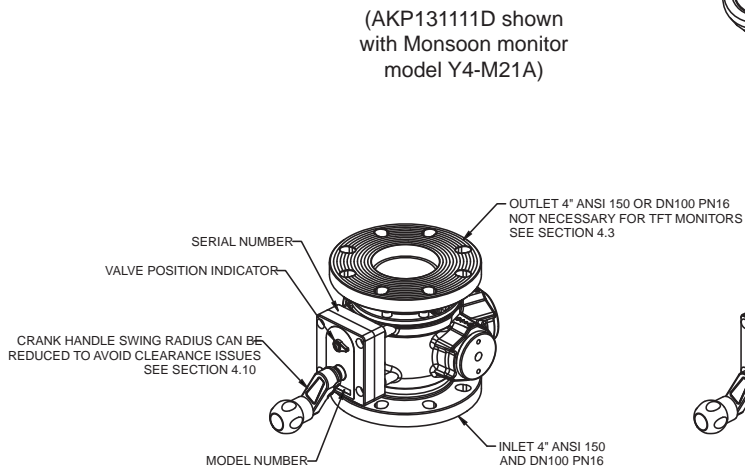

Figure 3.2b
VUM WITH CRANK HANDLE (PARALLEL DRIVE GEARBOX)

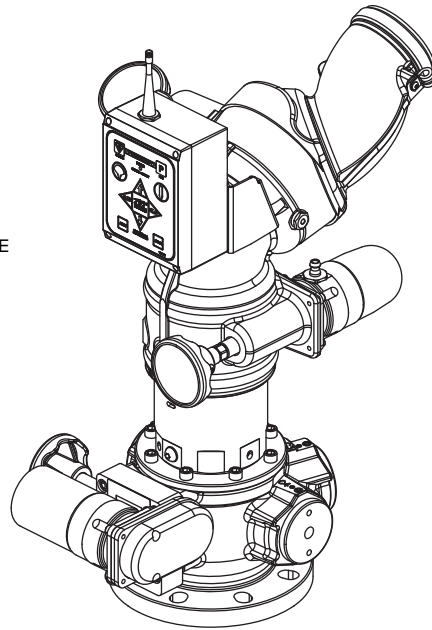
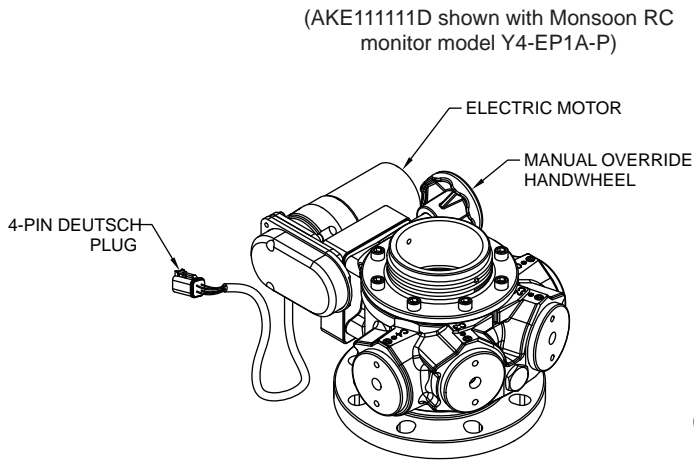

Figure 3.2c
VUM WITH ELECTRIC REMOTE CONTROL (VUM RC)

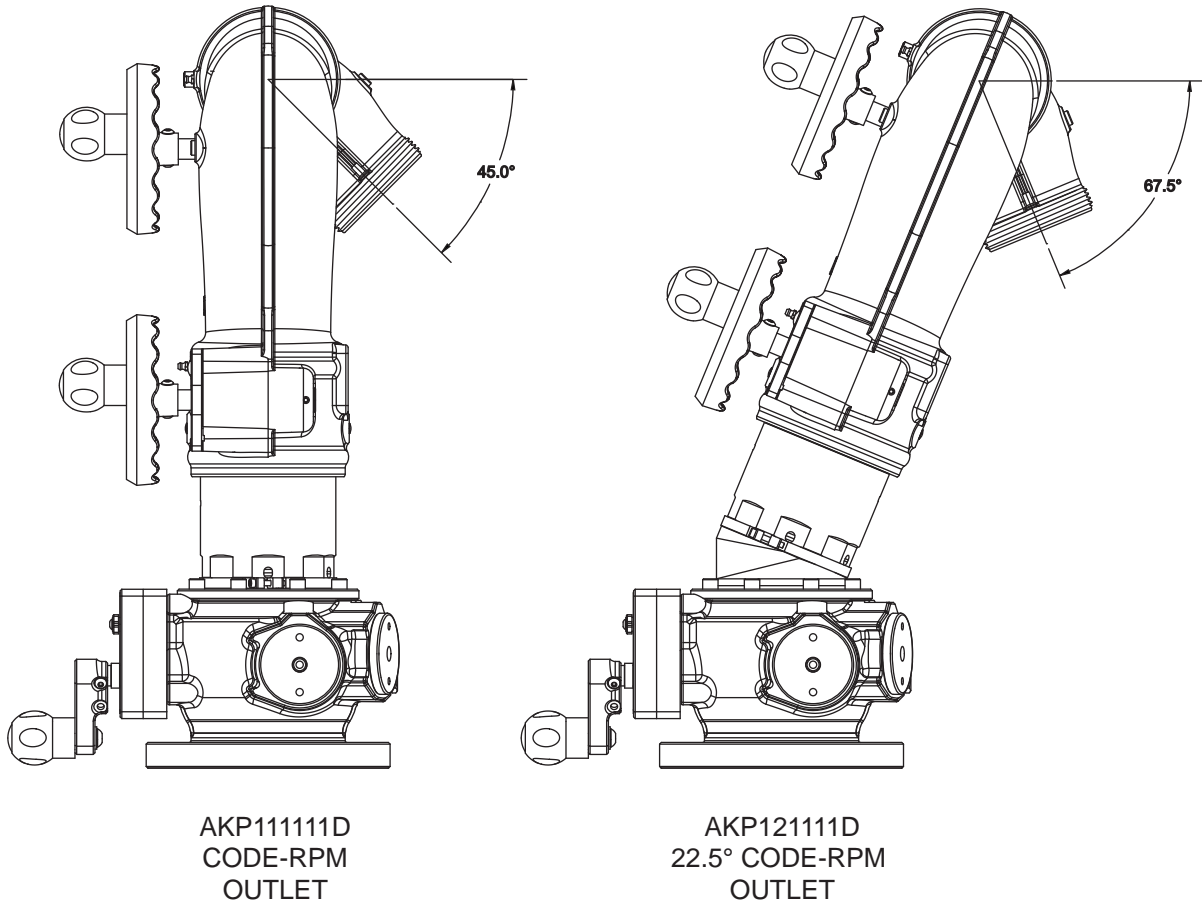

Figure 3.2d
VUM WITH 22.5° OUTLET
(shown with Typhoon monitor model Y5-DP1A)

- Only available for use with TFT monitors.
- Angle of monitor outlet is offset by 22.5° below horizontal (45° of travel below horizontal becomes 67.5°).
- Not all auxiliary port options are compatible with the 22.5° outlet, depending on which model monitor is used.
- Please consult TFT Service Department for any questions regarding option compatibility.

3.3 OVERALL DIMENSIONS AND WEIGHTS

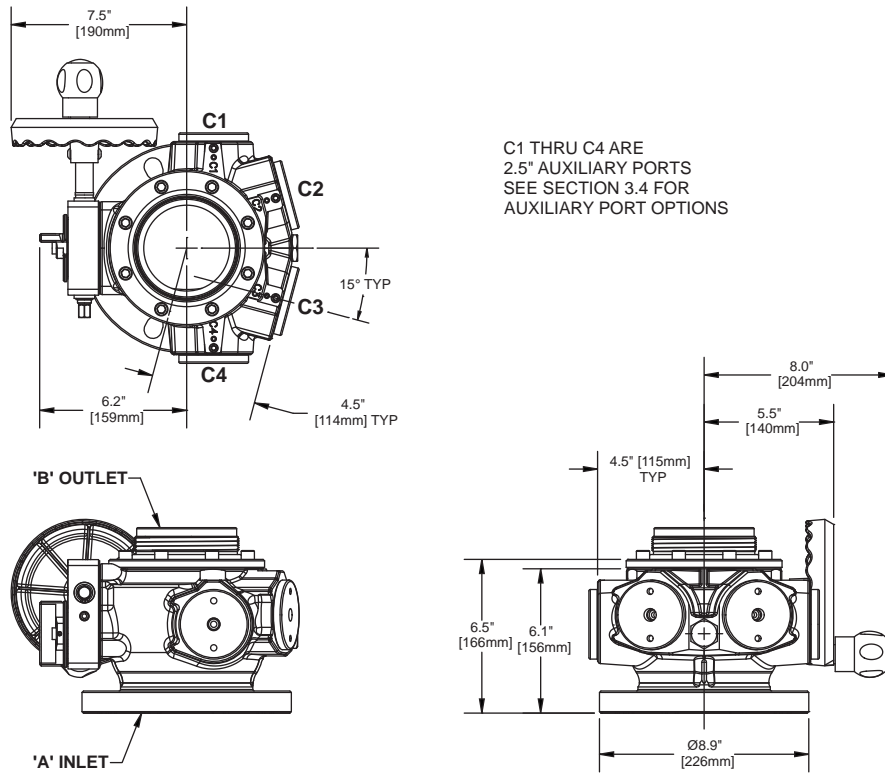

Figure 3.3a
VUM WITH MANUAL HANDWHEEL CONTROL (WORM DRIVE GEARBOX)
MODEL SHOWN: AKM111111D APPROXIMATE WEIGHT: 20.6 lbs (9.3 kg)

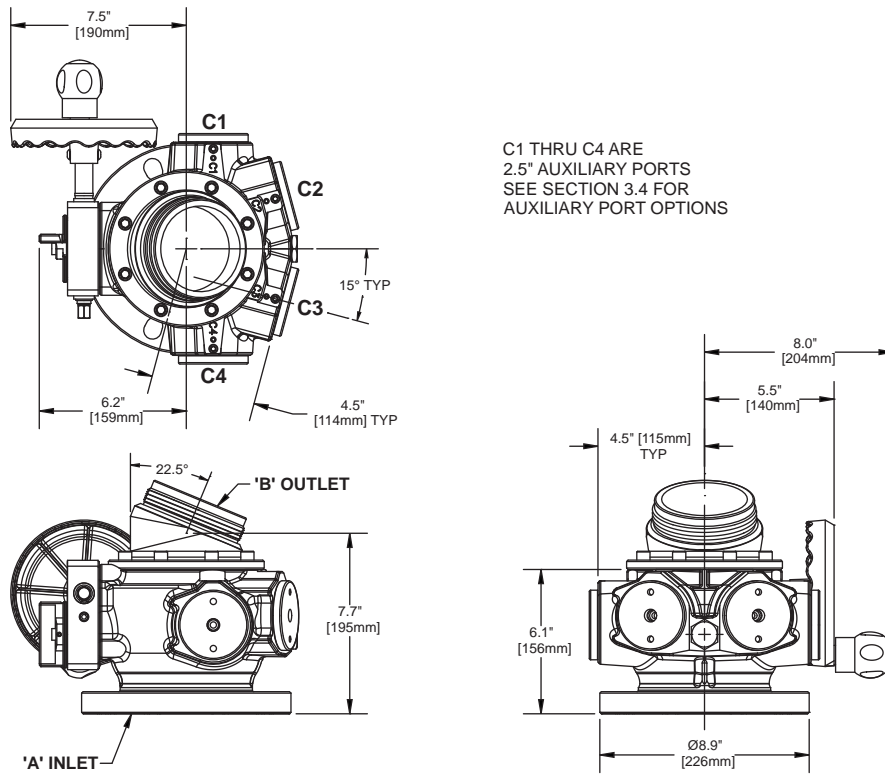

Figure 3.3b
VUM WITH 22.5° OUTLET MANUAL HANDWHEEL CONTROL (WORM DRIVE GEARBOX)
MODEL SHOWN: AKM121111D APPROXIMATE WEIGHT: 21.3 lbs (9.7 kg)

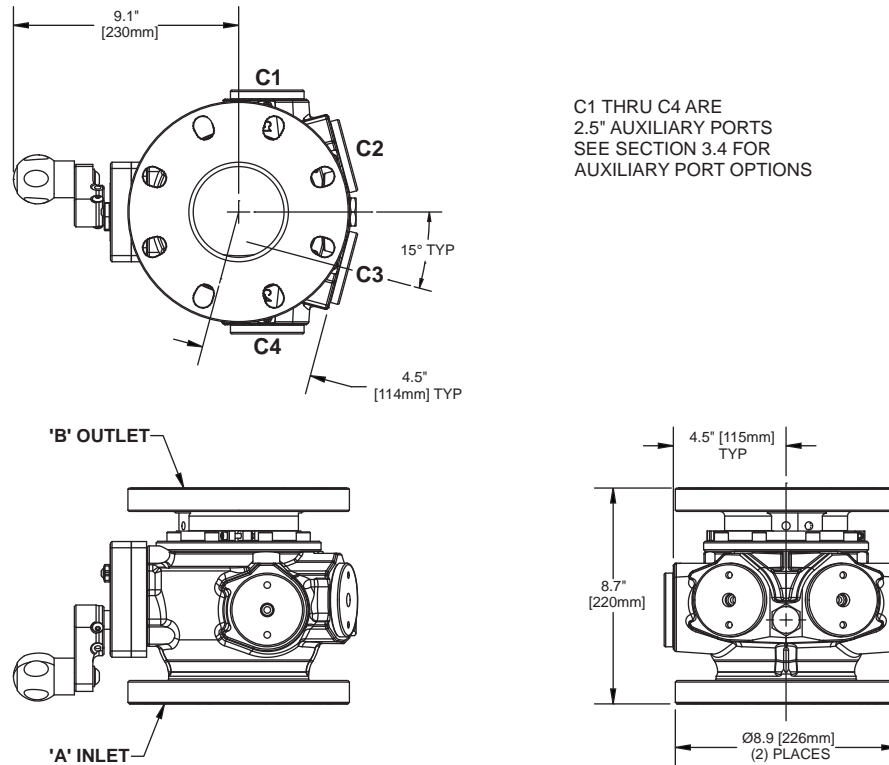

Figure 3.3c
VUM WITH CRANK HANDLE (PARALLEL DRIVE GEARBOX)
MODEL SHOWN: AKP131111D APPROXIMATE WEIGHT: 25.2 lbs (11.4 kg)

NOTES:

- Weight of Parallel Drive Gearbox with Crank Handle is similar to weight of Worm Drive Gearbox with Handwheel.
- Handwheel and Crank Handle are interchangeable parts.
- Specifying 4" ANSI 150 for the "B" outlet adds approximately 4.5 lbs (2.0 kg)

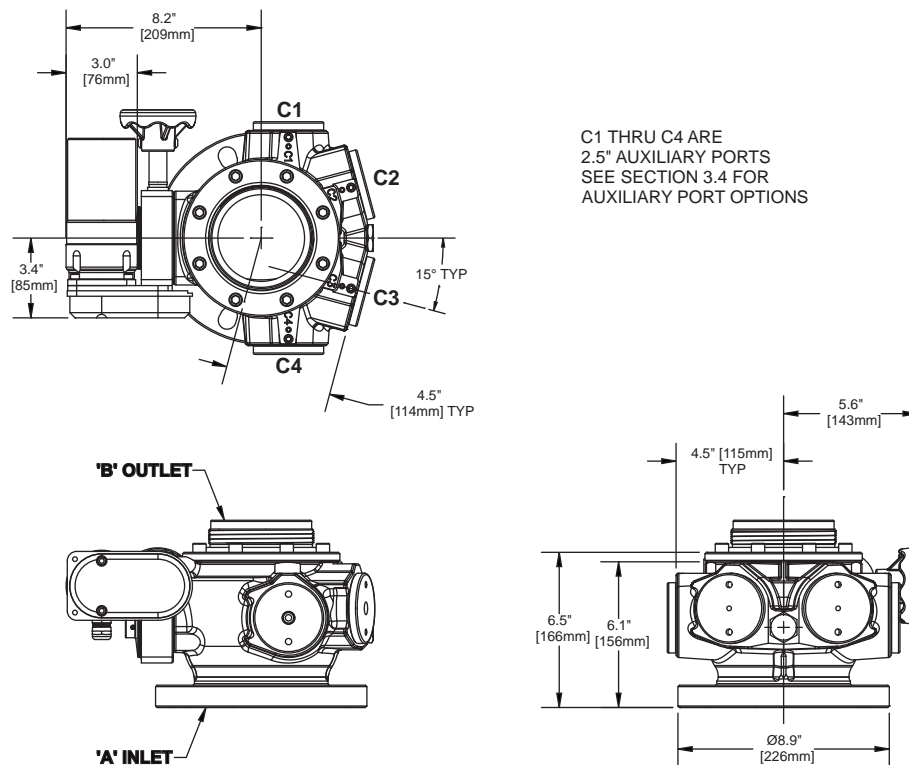

Figure 3.3d
VUM WITH ELECTRIC REMOTE CONTROL (VUM RC) MODEL SHOWN: AKE111111D
APPROXIMATE WEIGHT: 25.0 lbs (11.3 kg)

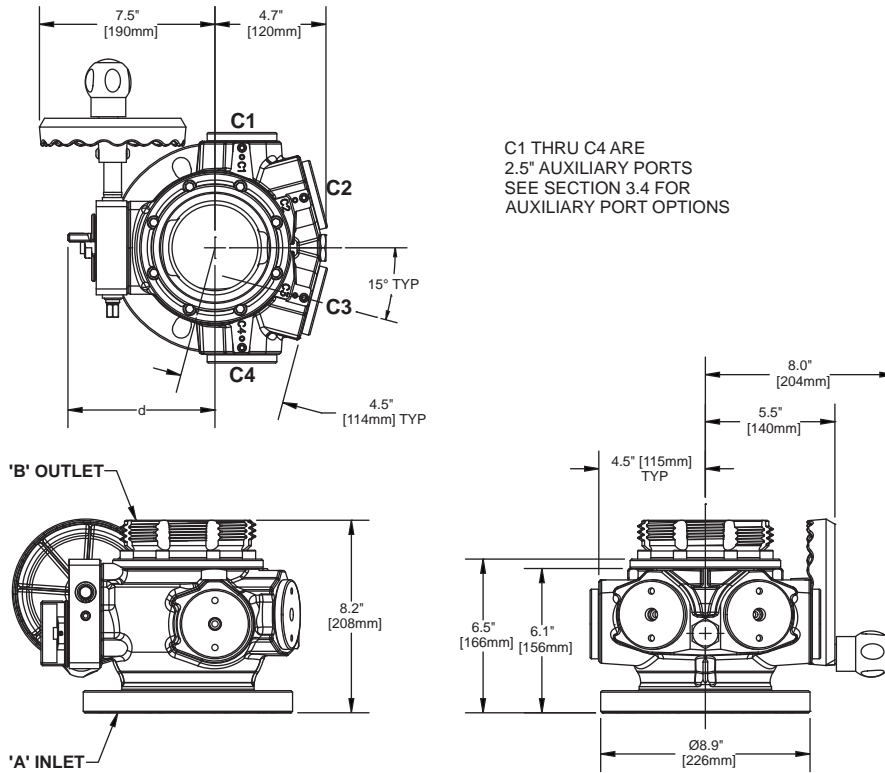

Figure 3.3e

VUM WITH 4.5"NH QUICK CONNECT FOR HURRICANE, TYPHOON & MONSOON (-*Q1A MODELS)
MODEL SHOWN: AKM1Q1111D APPROXIMATE WEIGHT: 23.0 lb (10.4 kg)

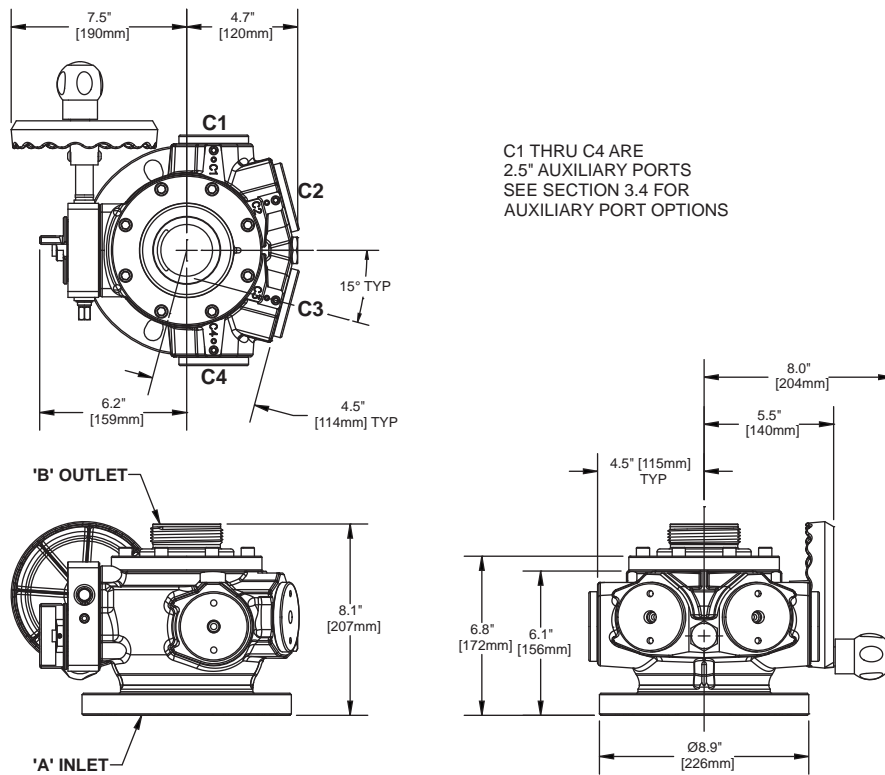

Figure 3.3f

VUM WITH 2.5"NH QUICK CONNECT FOR TORNADO & TORNADO RC (-*11A MODELS)
MODEL SHOWN: AKM1T1111D APPROXIMATE WEIGHT: 22.8 lb (10.3 kg)

3.4 AUXILIARY PORT OPTIONS, DIMENSIONS AND WEIGHTS

Several options may be specified to enhance the capabilities of the VUM. Any of the options shown in this section may be specified for each of the C1, C2, C3 and C4 ports. Certain options may not be suitable for placement adjacent to the handwheel or crank control. Most clearance issues can be avoided by planning around the dimensions from sections 3.3 and 3.4 and utilizing the handwheel or crank relocation instructions from sections 4.7 through 4.10.

If re-configuration is necessary, auxiliary options can be exchanged by removing 46 ball bearings through the 1/4"-28 set screw hole (A). It is not necessary to dismount the entire VUM if a high-flow vacuum source is available. A 2 hp shop vacuum with a small nozzle is adequate. Loosen the 3/8"-16 dog point set screw (B). While applying vacuum to (A), twist the auxiliary device in either direction to help free the ball bearings.

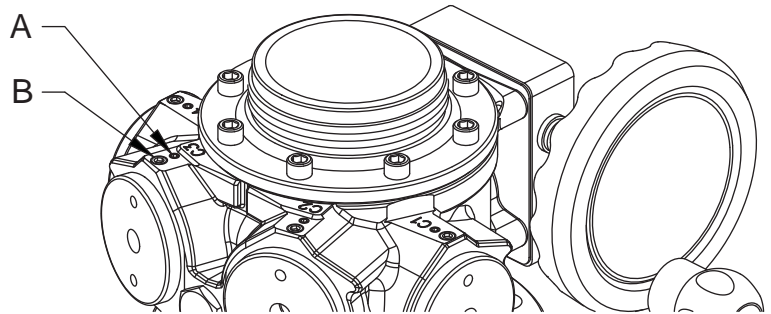

Figure 3.4

To twist a blind plug, a simple tool can be assembled by screwing a 2" long 1/4" NPT nipple and female tee into the blind tapped hole in the center of the blind plug. Twist clockwise as vacuum is applied until all ball bearings have been removed.

OPTION 1: BLIND PLUG

Typical port: ANY

Weight adjustment: NONE

NOTE: Blind plugs have 1/4" NPT threads tapped into a blind pilot hole. To install a pressure gauge or other accessory, first drill through the blind pilot hole with a 1/4" drill bit.

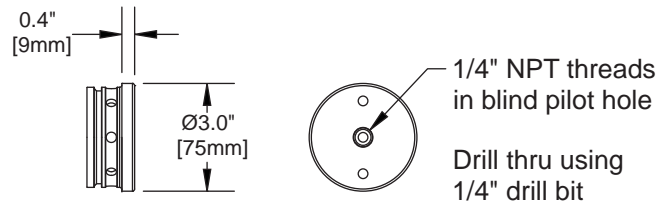

OPTION 2: GATED ELBOW LEFT-HAND 2.5" NH MALE

Typical port: C1

Weight adjustment: Add 5.7 lbs (2.4 kg) (includes adapter and cap shown in option 5)

NOTE: Gated elbows are able to pivot, reducing the likelihood and severity of hose kinks. When attached directly to ports C1-C4, pivot range is limited to $\pm 22.5^\circ$ to prevent interference between the monitor and the gated elbow. When attached to an extension pipe (options B and C), 360° rotation is possible. Rotation can be locked to any of 8 indexed positions using the 3/8"-16 dog point set screws shown in Figure 3.2a.

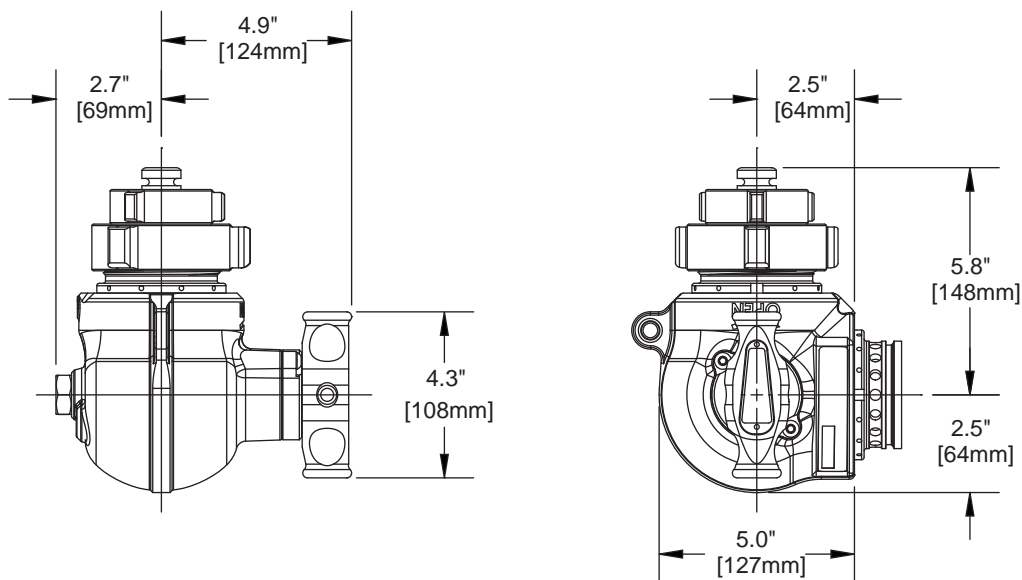

OPTION 3: GATED ELBOW RIGHT-HAND 2.5" NH MALE

Typical Port: C4

Weight adjustment: Add 5.7 lbs (2.4 kg) (includes adapter and cap shown in option 5)

NOTE: Gated elbows are able to pivot, reducing the likelihood and severity of hose kinks. When attached directly to ports C1-C4, pivot range is limited to $\pm 22.5^\circ$ to prevent interference between the monitor and the gated elbow.

When attached to an extension pipe (options B and C), 360° rotation is possible. Rotation can be locked to any of 8 indexed positions using the 3/8"-16 dog point set screws shown in Figure 3.2a

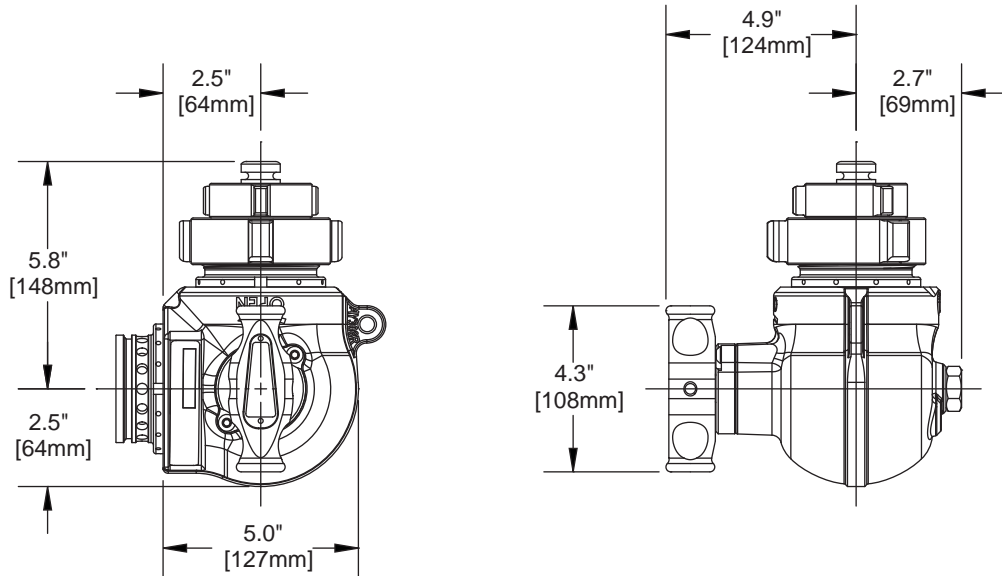

OPTION 4: STRAIGHT HYDRANT VALVE 2.5" NH MALE

Typical port: ANY

Weight adjustment: Add 5.7 lbs (2.4 kg) (includes adapter and cap shown in option 5)

NOTE: Up to four straight hydrant valves may be installed when the parallel drive gearbox, electric RC gearbox and/or crank handle are used. This is the preferred method of providing four 2.5" gated discharges.

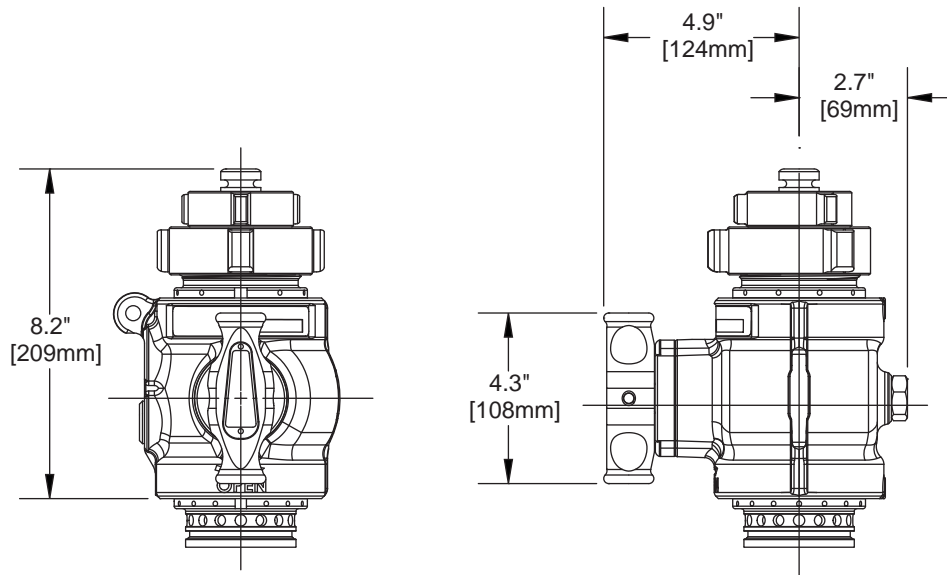

OPTION 5: 2.5" NH MALE HOSE THREADS (NO VALVE)

Typical port: ANY

Weight adjustment: Add 0.7 lbs (0.3 kg)

NOTE: Weight includes adapter and cap.

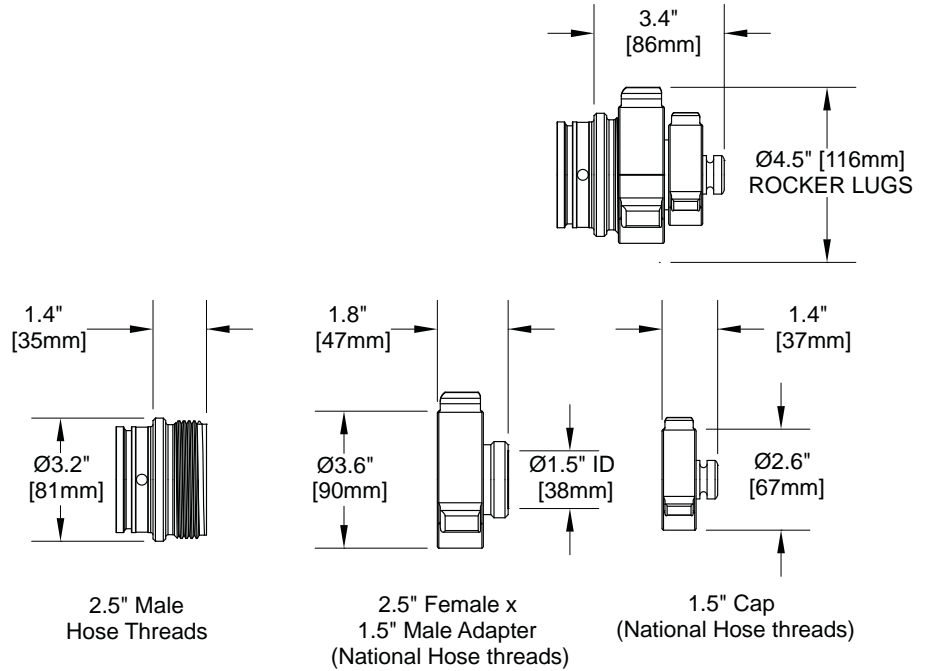

OPTION 6: 2.5" NPT FEMALE PIPE THREADS (NO VALVE)

Typical port: ANY

Weight adjustment: Subtract 0.3 lbs (0.1 kg)

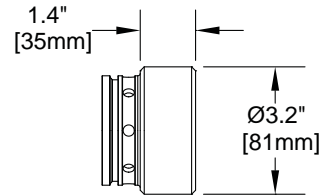

OPTIONS B THROUGH F: EXTENSION PIPE 4.75" LONG, FOLLOWED BY ONE OF THE ABOVE OPTIONS

Typical port: ANY

Weight adjustment: Add 1.8 lb (0.8 kg)

CORRESPONDING OPTIONS

A	B	C	D	E	F	G	H	J
1	2	3	4	5	6	7	8	9

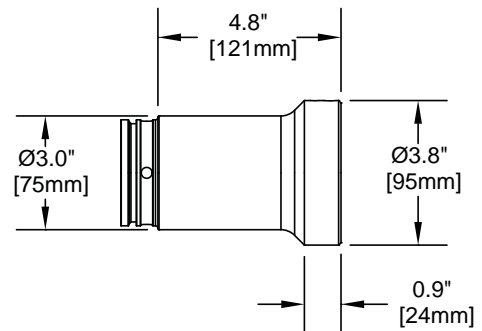

NOTES:

- Options 7-9 and G-J are reserved for future options.
- "A" (BLIND PLUG ON EXTENSION PIPE) is not an option.

3.5 CORROSION

All aluminum components are hardcoat anodized for corrosion resistance. Cast aluminum valve bodies are powder coated inside and out for additional corrosion resistance. The effects of corrosion can be minimized by good maintenance practice. See section 9.0 for maintenance.

3.6 USE WITH SALT WATER

Use with salt water is permissible, provided valve is thoroughly cleaned with fresh water after each use. The service life of the valve may be shortened due to the effects of corrosion and is not covered under warranty.

4.0 INSTALLATION

4.1 DIRECTION OF FLOW

This product is intended to be installed with the main valve seat towards the outlet end as shown in figure 4.1. This allows the auxiliary discharge ports to be used while the main valve (to monitor) is closed. If the direction of flow is reversed, the auxiliary discharge ports will not be active when the main valve is closed and the automatic drain valve will not seal (if so equipped).

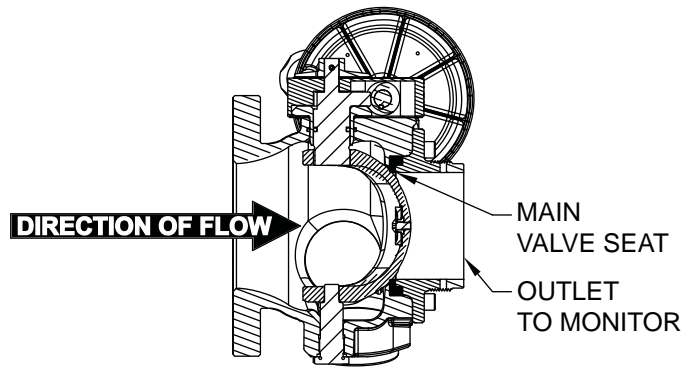

Figure 4.1

4.2 STRUCTURAL REQUIREMENTS FOR MONITOR MOUNTING



WARNING Injury can result from an inadequately supported monitor. The structure to which the Valve Under Monitor is mounted must be capable of withstanding the internal pressure of the monitor as well as shear and bending forces due to nozzle reaction. Nozzle reaction can be as high as 1500 lbs (680 kg) (2000 gpm at 200 psi, 1750 gpm at 250 psi). Flanges and pipe made from plastic are inadequate for valve mounting and must not be used. This valve is not intended for portable use.

For flanged connections, the use of flat flanges without raised faces is recommended. Use a ring gasket as defined in ASME 16.21 or ISO 7483. Tighten flange bolts in an alternating sequence as shown in figure 4.2. Tighten to 76-80 ft-lb (100-110 Newton-Meters).

Tighten sequentially each bolt three times.

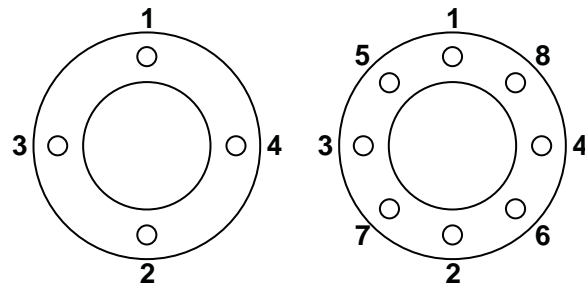

Figure 4.2
Flange Bolt Tightening Sequence

4.3 MONITOR INSTALLATION

The Valve Under Monitor may be equipped with either a CODE-RPM direct connection to TFT monitors or an ANSI / DN flange for use with other devices. Chart 4.3a shows the installed height of each VUM outlet option.

VUM OUTLET TYPE	INSTALLED HEIGHT
CODE-RPM	5.6" net*
22.5° ELBOW CODE-RPM	7.0" net* at center line
4" ANSI 150 FLANGE	8.7" (net = gross)
DN100 PN16 FLANGE	8.6" (net = gross)
* versus 4" ANSI 150 monitor without VUM. Gross height of CODE-RPM is 0.94" taller than net height – see figure 3.3a	

Chart 4.3a



WARNING Within the specified operating range, the Valve Under Monitor is designed to withstand nozzle reaction forces from monitors measuring up to 16" (406 mm) from the bottom edge of the monitor inlet to the center line of the monitor outlet. Injury can result from the reaction forces of monitor outlets located more than 16" (406 mm) from the inlet. Figure 4.3b shows examples of acceptable and forbidden monitor installations using the Valve Under Monitor.

WARNING

Do not use the Valve Under Monitor with monitor extension pipes such as the Task Force Tips Extend-A-Gun. Injury can result from the reaction forces and overall weight from this combination of products.

FOR MONITOR MODELS NOT SHOWN BELOW, PLEASE CONSULT TFT SERVICE DEPARTMENT.

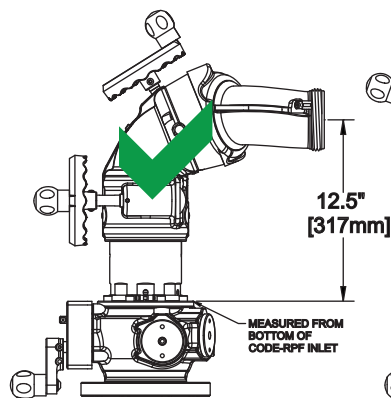

ACCEPTABLE
TFT CODE-RPF AND
QUICK CONNECT MONITORS
MEASURING LESS THAN 19"
EXAMPLES:

- MONSOON Y4-MP1A or MQ1A
- MONSOON Y4-TP1A or TQ1A
- MONSOON RC Y4-EP1A or EQ1A
- TYPHOON Y5-DP1A or DQ1A
- TYPHOON Y5-MP1A or MQ1A
- TYPHOON Y5-TP1A or TQ1A
- TYPHOON RC Y5-EP1A-L or EQ1A-L
- TYPHOON RC Y5-EP1A-P or EQ1A-P
- HURRICANE XFIH-DP1A or DQ1A
- HURRICANE XFIH-TP1A or TQ1A
- HURRICANE RC XFIH-EP1A or EQ1A
- TORNADO Y2-T11A or TV1A
- TORNADO RC Y2-E11A or EV1A

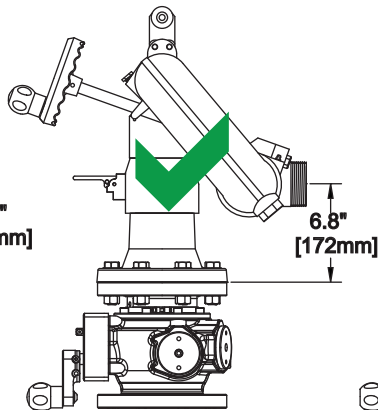

ACCEPTABLE
FLANGED MONITORS
MEASURING
LESS THAN 16"
EXAMPLES:

- HURRICANE XFI-FPNJ
- HURRICANE XFIE-FPNJ
- HURRICANE XFIH-D21A*
- HURRICANE XFIH-T21A*
- HURRICANE RC XFIH-E21A*
- MONSOON Y4-M21A *
- MONSOON Y4-T21A *
- MONSOON RC Y4-E21A *

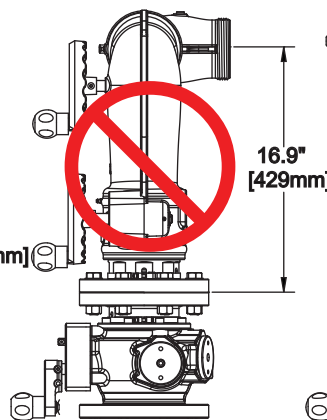

FORBIDDEN
FLANGED MONITORS
MEASURING
GREATER THAN 16"
EXAMPLES:

- PROTECTOR Z121A
- PROTECTOR Z1221A
- TYPHOON Y5-D21A *
- TYPHOON Y5-M21A *
- TYPHOON Y5-T21A *
- TYPHOON RC Y5-E21A-L *
- TYPHOON RC Y5-E21A-L20 *
- TYPHOON RC Y5-E21A-L80 *
- TYPHOON RC Y5-E21A-P *

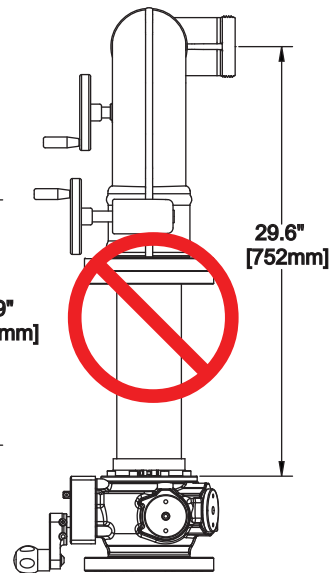

FORBIDDEN
MONITORS ON
EXTENSION PIPES
ABOVE THE VUM
EXAMPLES:

- TFT EXTEND-A-GUN
- AKRON® 3406 ELECTRIC RISER
- ELKHART® EXTENDER

***FLANGES (4" ANSI 150 OR DN100 PN16) CAN BE REMOVED FROM MOST TFT MONITORS IN ORDER TO USE THE CODE-RPM DIRECT CONNECTION.**

Figure 4.3b
ACCEPTABLE AND FORBIDDEN MONITOR INSTALLATIONS

CODE-RPM DIRECT CONNECTION TO TFT MONITOR:

Direct connection saves approximately 10 lbs (4.5 kg) of weight and 3" (76 mm) of height by omitting flanges from both the VUM outlet and TFT monitor inlet. An additional benefit of this connection is reduced labor for monitor and valve maintenance.

Direct connection consists of CODE-RPM (male threads) on the VUM outlet and CODE-RPF (female threads) on the monitor Base with an o-ring seal. Two different methods of rotational locking between the monitor Base and the VUM outlet exist. One method relies on two ¼-28 Button Head Cap Screws, and the other, newer version, uses a two piece Clamp that is held together with #10 Cap Screws and Cylindrical nuts. The rotational locking method employed can be identified by the presence or absence of two threaded cross-holes, 180 degrees apart in the threaded portion of the VUM outlet, where the monitor Base screws onto the VUM. If ¼-28 Screws are needed, there will be ¼-28 threaded cross-holes in the threaded portion of the VUM outlet. If Clamps are needed, there will be no ¼-28 threaded cross-holes in the threaded portion of the VUM outlet. Once the necessary rotational locking method is determined, install the monitor using one of the following procedures.

1/4-28 Button Head Cap Screw Rotational Lock Installation Instructions (with tapped holes, refer to figure 4.3c)

1. Verify that the threaded cross holes on the VUM OUTLET will allow the desired orientation of the Straight Ahead Reference Mark" when aligned with one of the pairs of slots on the monitor INLET BASE. If alignment is acceptable, proceed to step 2.
If alignment is not acceptable, VUM OUTLET may be rotated in 45° increments as described below. When combined with the multiple slot orientations on the monitor inlet, the monitor may be oriented at any 22.5° interval with respect to the VUM bolt hole pattern. To rotate the VUM OUTLET:
 - Remove eight 3/8-16 socket head cap screws. Pull the OUTLET away from the VUM BODY and VALVE SEAT, taking care to avoid damage to any sealing surfaces or threads.
 - Orient the VUM OUTLET as desired, then press outlet firmly against VUM BODY and VALVE SEAT.
 - Apply Loctite #242 (blue) compound to 3/8-16 screws and tighten to 180 to 200 in-lb (15 to 17 ft-lb) using the alternating sequence shown in figure 4.1.
2. Screw monitor onto VUM until threaded joint bottoms out.
 - Do not use pipe sealant or Loctite on the inlet base threads. These threads are sealed with an o-ring. Use of thread locking compounds will make removal difficult.
3. Unscrew monitor slightly until the Straight Ahead Reference Mark is facing the desired orientation.
 - Adjust the rotation as needed to align a pair of slots on the monitor INLET BASE with the threaded cross holes in the VUM OUTLET.
 - It is acceptable for the monitor to be unscrewed up to one full turn from the bottomed out position.
4. Install 1/4-28 by 1/2 long socket head cap screws and washers in the two threaded cross holes. Use Loctite #271 (red) on the threads of the socket head cap screws. Allow Loctite to fully cure before applying water pressure.



Applying greater than 200 in-lbs(17 ft-lbs) torque to valve seat retainer screws may damage the valve body. Injury could result from use after damaging the valve body.

MOUNTING A MONITOR WITH 4" ANSI 150 or DN100 PN 16 FLANGE with 1/4-28 tapped holes:

1. Verify that the bolt pattern of the VUM outlet flange will allow the desired orientation of the monitor. If alignment is acceptable, proceed to step 2.
If alignment is not acceptable, the flange may be rotated 22.5° degrees:
 - Remove 1/4-28 x 1/2 long socket head cap screws and washers from cross holes below outlet flange.
 - Adjust rotation of outlet flange until threaded cross holes are aligned in alternate position.
 - Replace 1/4-28 x 1/2 long socket head cap screws and washers. Use Loctite #271 (red) on the threads of the socket head cap screws. Allow Loctite to fully cure before applying water pressure.
2. Install Monitor onto VUM outlet flange using instructions from section 4.2.

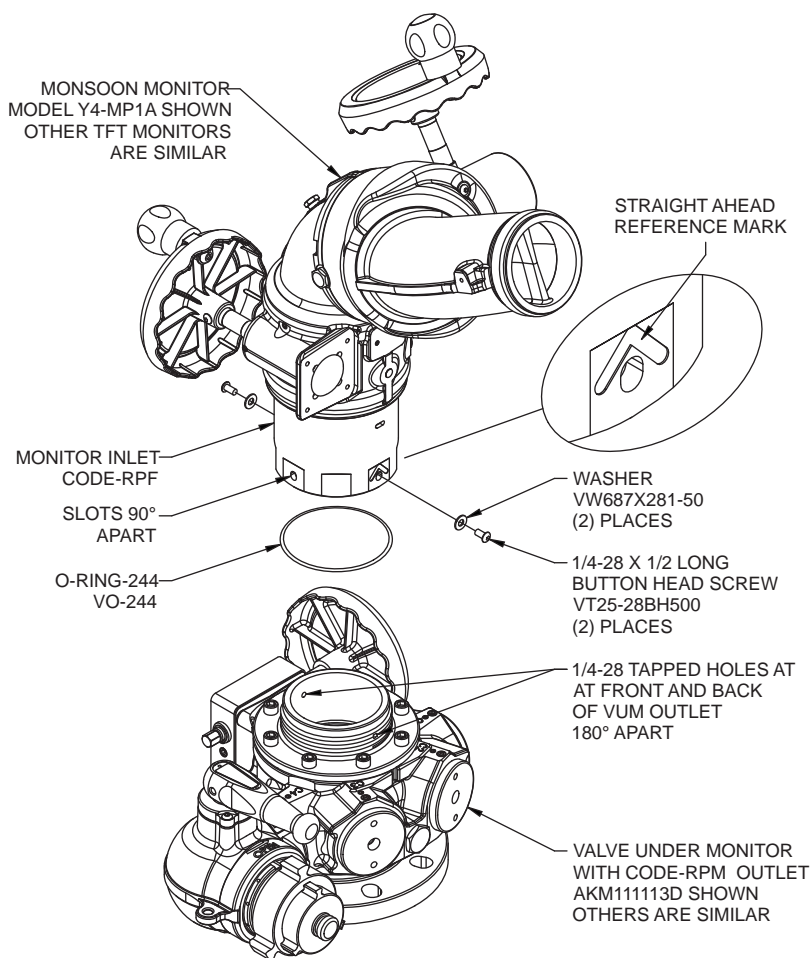

Figure 4.3c
CODE-RPM DIRECT CONNECTION
with 1/4-28 tapped holes

TWO PIECE CLAMP ROTATIONAL LOCK INSTRUCTIONS (without tapped holes, refer to figure 4.3d):

1. Assemble Clamps and place loosely on VUM outlet.
2. Screw monitor onto VUM until threaded joint bottoms out.
 - **CAUTION:** Make sure the Clamps are not tight enough to prevent the monitor Base from bottoming out. The monitor will leak if it does not bottom out in this step.
 - Do not use pipe dope or Loctite on the monitor base threads. These threads are sealed with an O-ring. The use of thread locking compounds will make removal difficult.
3. Unscrew monitor until the "Straight Ahead Reference Mark" is facing the desired direction.
 - Monitor may be unscrewed up to one full turn from the bottomed out position.
 - **CAUTION:** Monitor will leak if unthreaded more than one full rotation from bottomed-out condition.
4. Rotate the Clamps to the desired orientation. Ensure that Clamp assembly does not interfere with RC monitor Power/Com Cable (if applicable).
5. Tighten each Screw gradually until both are finger tight with approximately equal spacing between opposite ends of Clamps.
6. Carefully tighten each Screw one additional turn using a 5/32 hex wrench by alternating to the opposite Screw in half turn increments. **CAUTION:** Over tightening the Screws will damage Screws and Clamps.

MOUNTING A MONITOR WITH 4" ANSI 150 or DN100 PN 16 FLANGE (new version with clamps):

1. Verify that the bolt pattern of the VUM outlet flange will allow the desired orientation of the monitor. If alignment is acceptable, proceed to step 2. If alignment is not acceptable, the flange may be rotated using the following steps.
 - Slightly loosen two Screws on Clamps until the outlet flange is able to rotate.
 - Rotate outlet flange as desired.
 - Tighten each Screw gradually until both are finger tight with approximately equal spacing between opposite ends of Clamps.
 - Carefully tighten each Screw one additional turn using a 5/32 hex wrench by alternating to the opposite Screw in half turn increments.**CAUTION:** Over tightening the Screws will damage Screws and Clamps.
2. Install Monitor onto VUM outlet flange using instructions from section 4.3.

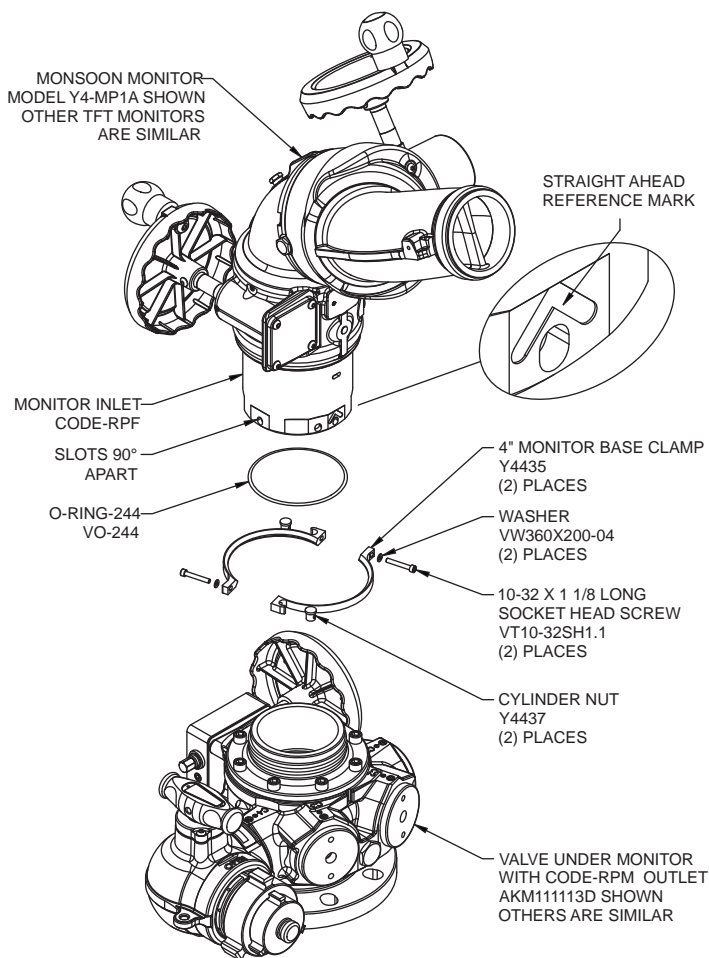

Figure 4.3d
CODE-RPM DIRECT CONNECTION WITH TWO PIECE CLAMPS

4.4 ELECTRIC INSTALLATION AND WIRING

Red (+) and black (-) wires of the Valve Interface Box must be connected to a 12 or 24 VDC protected circuit from the truck's power distribution center. To control the valve from a TFT RC monitor operator station, the valve's Blue and White communication wires must be connected to the monitor's blue and white wires as described in RC Monitor Electrical Controls supplement (LIY-500), section 2.0. Figure 4.4 shows the RC VUM typical control connections.

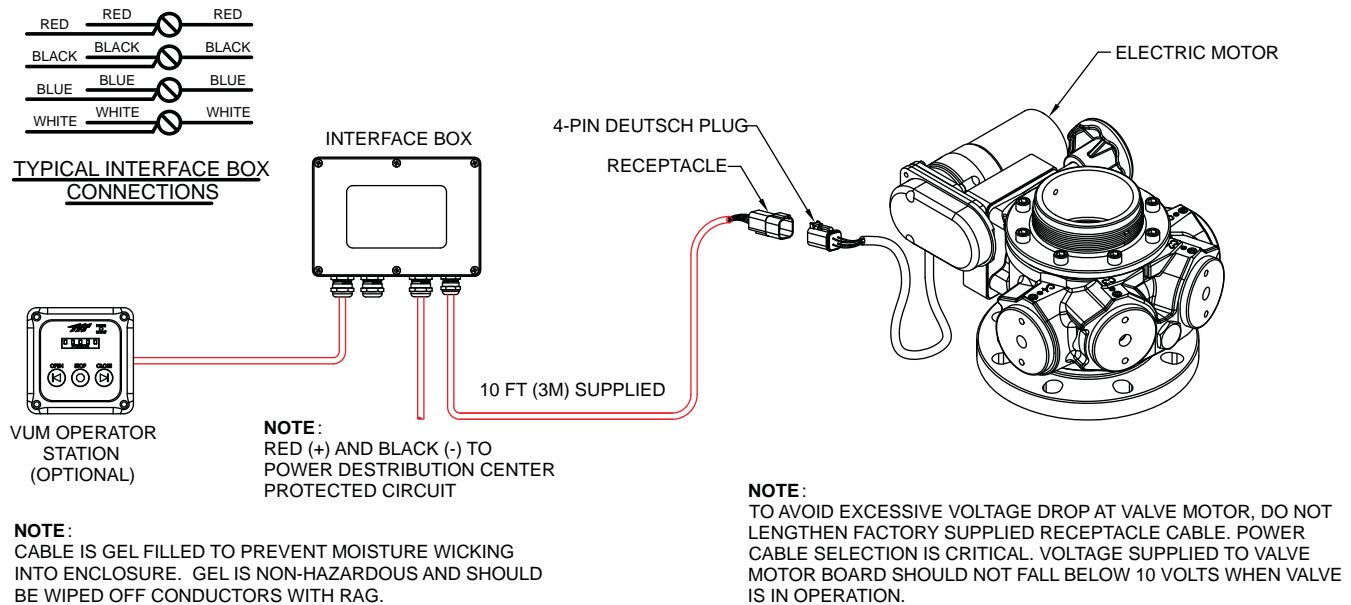

Figure 4.4



The electric motor and other components are ignition sources. The Valve Under Monitor RC should be operated only in areas where there is adequate ventilation and no hazard of flammable vapor buildup.

4.4.1 INTERFACE ENCLOSURE MOUNTING

Select enclosure location. Enclosure is designed to be surface mounted and the size is 4 3/4 x 6 3/4 (120mm x 170mm).

Height of enclosure is 2 1/4" (57mm). Refer to figure 4.4.1 for mounting hole dimensions. A full size template is provided in section 11.0

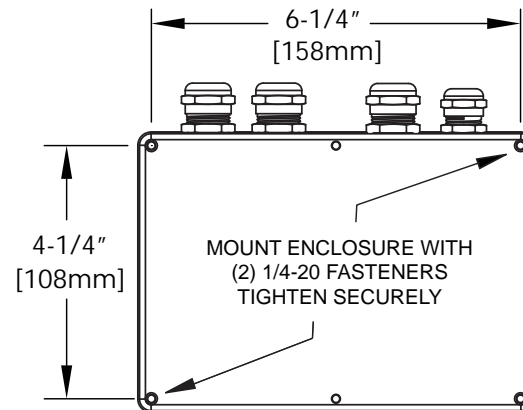

Figure 4.4.1
Valve Interface Enclosure Mounting Hole Dimensions

4.5 ELECTRICAL TESTING

VERIFY PROPER VOLTAGE

The TFT Valve Under Monitor RC has built in circuit protection to guard against a circumstance where the unit's movement is blocked before reaching its full travel limits. Without this circuitry the motor would stall, overheat, and could be permanently damaged.

IMPORTANT - When mechanical installation and electrical connections are complete, perform the following test to verify voltage supply is adequate and the current limiting feature is functioning.

1. Apply power to valve controls.
2. Activate Open or Close inputs until valve reaches stop position. Continue to hold button down.
3. Once movement is stopped, manually turn override knob in opposite direction while input is active. If knob can be turned, then voltage supply is adequate. If knob can't be turned and motor continues to operate, then the current limit was not reached because the voltage supply or wiring is not adequate.

NOTE: Override knob will only turn in one direction.

To ensure proper voltage to the Valve Under Monitor RC, the wiring needs to be checked for proper gauge for the installed length of wire, and for proper termination. Also, ensure that the power source supplying the VUM RC and the grounding are adequate (other electrical loads on a shared circuit with the VUM RC may cause a low-voltage situation).

In addition to motor damage, a further consequence of low voltage could be that the valve will not open or close properly or fully.

SET TRAVEL STOPS

When proper voltage is verified, perform the following to set the full travel limits.

1. Apply power to Valve Controls.
2. Activate CLOSE input until valve is fully closed. Motor must stop by current limit method. If motor continues to operate see proper voltage section above.
3. Activate OPEN input and continue to hold until valve is fully open. Motor must stop by current limit method. If motor continues to operate see proper voltage section above.
4. OPEN/CLOSE input relays will now track valve movement.

4.6 INPUTS SIGNAL CONFIGURATION

The Valve Interface box is shipped from the factory configured to accept +12/24 volt DC input signals, but can be field changed to accept ground input signals. To change configuration:

1. Remove lid from box
2. Locate DIP switches on A5830 board
3. Slide DIP switch #4 to the OFF position to select GROUND inputs or slide to the ON position to select VOLTAGE input.
4. Replace lid. Verify rubber seal is clean and undamaged. Verify that no wires are caught between lid and box.

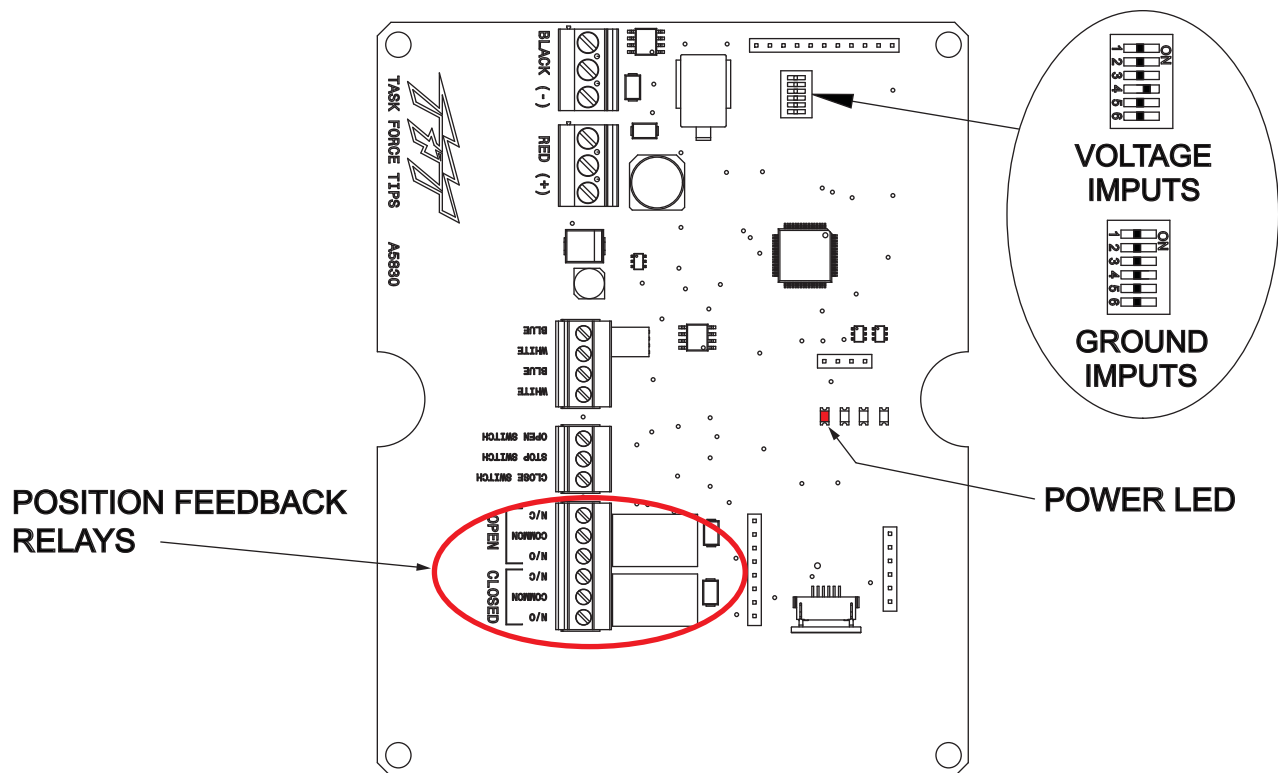

Figure 4.6

4.7 VALVE POSITION FEEDBACK RELAYS

The Valve Interface Box provides position feedback for the user to indicate which position the valve is in. The position relays are energized when the valve is in the corresponding position. The contact rating of the relay is 1 amp @ 30VDC for resistive loads and 0.2 amps @ 30 VDC for inductive loads.

The position relays have one dry Form-C contact (common, normally open, normally closed) that can be used. Figure 4.6 shows the terminal blocks available for user wiring.

4.8 AUX BUTTON OPERATION

The VUM RC can be operated from any TFT RC Monitor operator station equipped with AUX1/AUX2 buttons. The VUM RC is factory configured to operate from AUX2 button, but can be changed to operate from AUX1 button. To change follow these steps:

1. Turn off power.
2. Remove ring and cap from back of motor. (see figure 7.0d)
3. Slide DIP switch #1 to desired position (see figure 4.8a)
4. Replace cap and ring.
5. Apply power.

Each Valve Under Monitor RC is shipped with several button overlays with adhesive that can be attached to any RC monitor operator station with an AUX button. If additional overlays are needed, contact factory.

Clean operator station surface to remove any oils or residues. Carefully peel off overlay and place on top of AUX button, just inside blue border of button as shown in figure 4.8b

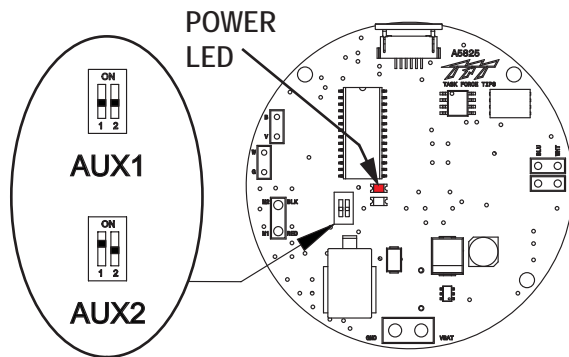

Figure 4.8a

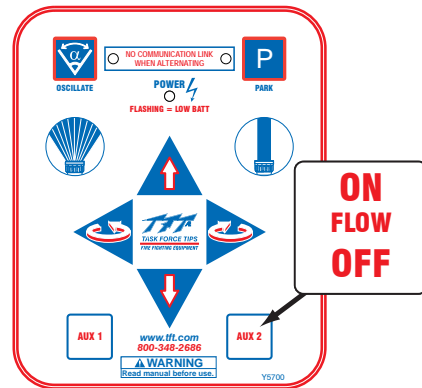

Figure 4.8b
Aux Button Overlay

4.9 CHANGING HANDWHEEL OR CRANK TO RIGHT SIDE – MANUAL MODELS

Side-mounted handwheels are factory configured on the left hand side of the valve. The hand wheel can be switched to the right hand side for convenience or if it interferes with other equipment on the apparatus. For greater clearance, the A1623 crank handle subassembly can be substituted for the handwheel subassembly (see section 4.11). To move the handwheel to the opposite side:

1. Remove the retaining ring on the end of the shaft.
2. Pull the shaft out of the gear box.
3. As the shaft is withdrawn, grasp the small key on the shaft so it does not get lost.
4. Remove and switch the two plastic bushings that come out of the sides of the gearbox. The bushing with the large hole is installed on the same side as the handwheel.
5. Apply a small dab of grease to the key and insert it into slot on the shaft.
6. Look through the gear box and note approximate position of the keyway in the worm inside the gear box. Slide the shaft into the gearbox on the opposite side of the gear box with the key oriented the same as the keyway. Rotate the shaft until the key finds the keyway and continue to slide the shaft until the hex flats protrude from the small bushing. The retaining ring groove should be exposed near the hex flats.
7. Reinstall the retaining ring. Do not over expand the retaining ring.

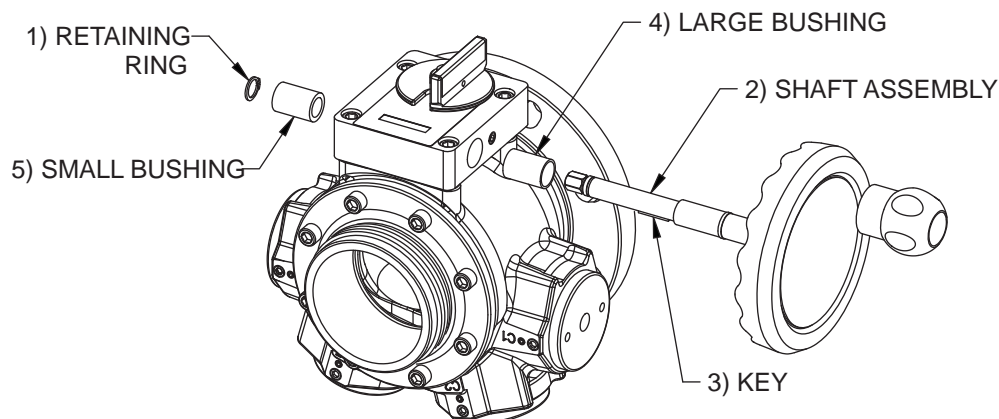

Figure 4.9

4.10 CHANGING HANDWHEEL OR CRANK TO RIGHT SIDE – RC MODELS

1. Remove screws and end cover.
2. Slide off both sprockets and chain as one unit.
3. Remove button head screw and lock washer to remove motor unit.
4. Remove set screw from opposite side of gearbox and reinstall it in the hole where the motor unit was mounted. The set screw plugs the hole to keep dirt from entering the gearbox.
5. Remove 4 screws and reposition motor so electric wire points in desired direction.
6. Change hand wheel to other side as in Section 4.9.
7. Reverse steps 1, 2 and 3 to reinstall motor on other side.
8. Reverse polarity (direction) of motor by holding OPEN and CLOSE buttons simultaneously for 15 seconds. Cycle power to unit.

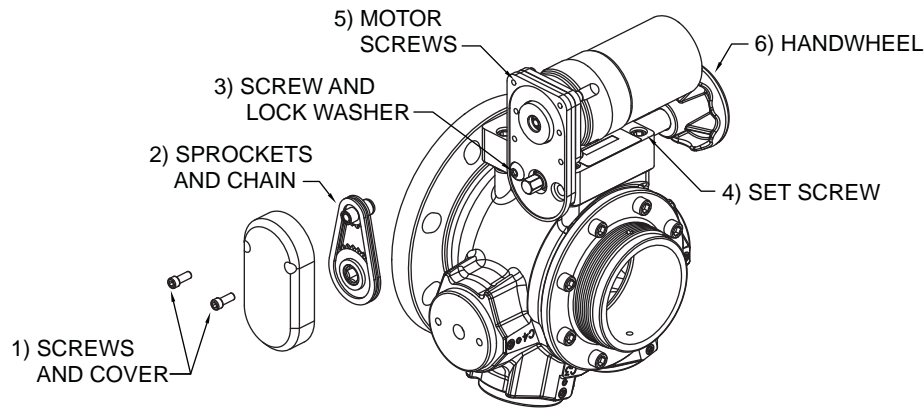

Figure 4.10

4.11 SHAFT EXTENSION FOR HANDWHEEL OR CRANK HANDLE

To avoid obstructions or enhance usability, the A1037-KIT shaft extension kit is available for use on both handwheels and crank handles. This kit relocates the handwheel or crank handle 5" further from the gearbox. If further extension is desired, two standard extensions or a custom length extension may be used, with the addition of a support collar to prevent damage to the shaft and gearbox components. Support collars and/or custom length shafts may be constructed based on the dimensions in figure 4.9 below. It is recommended that the support collar constrains the smaller $\frac{3}{4}$ " end of the extension. The $\frac{11}{16}$ " hex flats are not necessary for custom shafts.

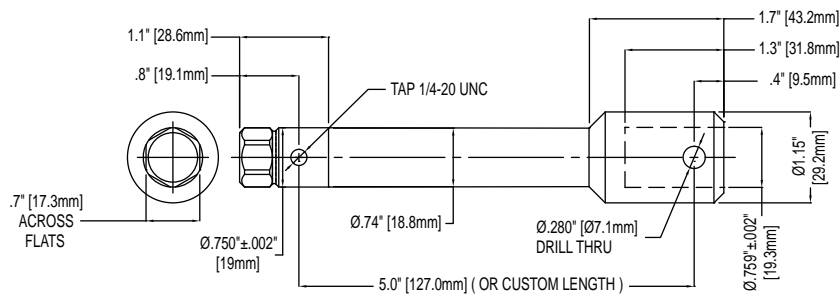

Figure 4.11

4.12 CHANGING OFFSET OF CRANK HANDLE

When equipped with a crank handle, two offset positions are available to adjust the swing radius of the crank and knob as shown in figure 4.12. The longer offset position offers reduced effort to operate the valve. The shorter offset is available to avoid interference with other equipment on the apparatus. To change the offset, remove two $\frac{3}{8}$ "-16 x 1-1/2 button head cap screws from crank. Place crank in desired position and replace screws.

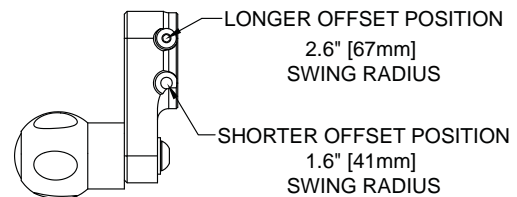

Figure 4.12

4.13 ALUMINUM HANDLE KITS FOR 2.5" GATED ELBOWS AND STRAIGHT HYDRANT VALVES

Two aluminum handle options are available for the 2.5" Gated Elbows and Straight Hydrant Valves. Each kit is supplied with a 5/16-18 x 1" long socket head cap screw and a packet of Loctite #242 (blue) to secure the handle.

The AY322-KIT T-Handle minimizes the potential for interference with the monitor and/or apparatus, while still providing sufficient mechanical advantage to open the valve. The T-Handle is installed by default when side B options 1, 2, 3, T or V are specified. AY322-KIT is not compatible with the 4.5" quick connect outlet (option Q).

The AY321-KIT Long Handle provides greater mechanical advantage, however the longer swing radius may result in interference with certain combinations of monitor and/or apparatus. The Long Handle is installed by default when the quick connect outlet (option Q) is specified on side B.

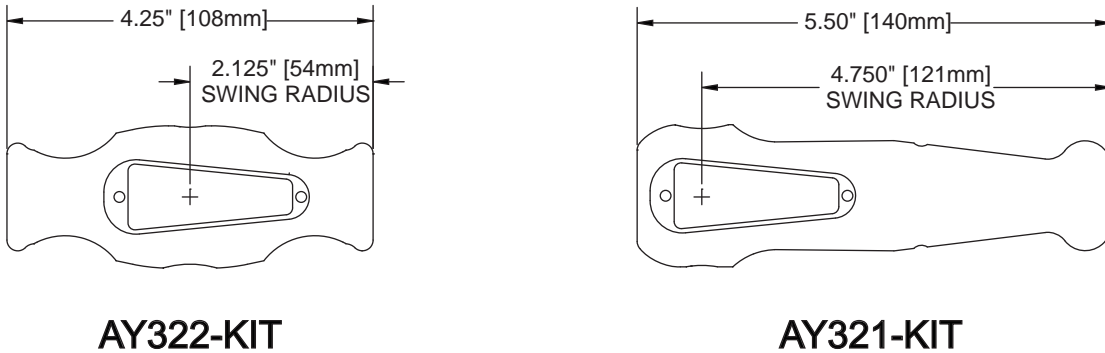

Figure 4.13

5.0 USE

5.1 VALVE POSITION INDICATOR

To open the valve, turn the handwheel or crank handle until the pointer indicates "OPEN". To close the valve, turn the handwheel or crank handle the opposite way until the pointer indicates "CLOSED".

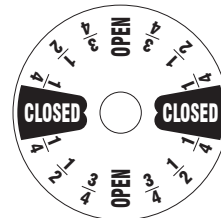

Figure 5.1

5.2 ELECTRIC REMOTE CONTROL - MANUAL OVERRIDE

The Valve Under Monitor RC is motor driven but also has an override handwheel for operating the valve manually. The override handwheel may also be used in the event of power failure. If electrical power is supplied to the control panel then the LED valve position display will track the valve's position as the handwheel is moved. If the handwheel is moved while there is no power to the electric controls then the LED valve position display will be in error when the electric power is reconnected. The LED valve position indicator will self correct the first time the valve is cycled under electric control.

If more compactness is desired, the override handwheel may be removed. The drive shaft has a hex so a wrench or socket may be used for manual override. If the manual override handwheel is removed assure that the correct size wrench or socket is available in the event of power failure.

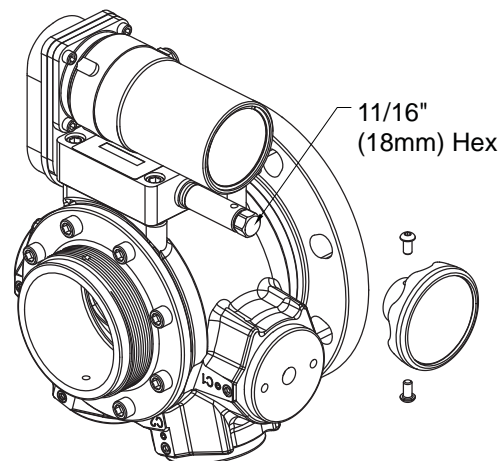

Figure 5.2

5.3 ELECTRIC REMOTE CONTROL OPERATION

Power LED:

LED will be solid green when power is present.

Flashing green LED indicates low voltage.

Changing Modes (Unit is shipped from factory in the Automatic Mode):

- Activate CLOSE and STOP inputs together for 3 seconds to change to Automatic Mode.
- Activate OPEN and STOP inputs together for 3 seconds to change to Manual Mode.

Manual Mode – not connected to TFT RC monitor:

- Activating OPEN input will cause valve to open.
- Deactivating OPEN input will cause valve to stop.
- Activating CLOSE input will cause valve to close.
- Deactivating CLOSE input will cause valve to stop.
- STOP input is not applicable in Manual Mode.

Manual Mode – when connected to TFT RC monitor:

- Activating AUX2 signal or OPEN input will cause valve to open.
- Deactivating AUX2 signal or OPEN input will automatically cause valve to close.

Automatic Mode – not connected to TFT RC monitor:

- Activating OPEN input (momentarily) will cause valve to travel to full open position.
- Activating CLOSE input (momentarily) will cause valve to travel to full close position.
- Activating STOP input while valve is moving will stop valve.

Automatic Mode – when connected to TFT RC monitor:

- Activating AUX2 signal will cause full travel. If valve was open, it will move closed and vice-versa.
- Activating AUX2 signal while valve is moving will cause valve to stop momentarily, then reverse direction to full travel.
- Activating OPEN input will cause valve to travel to full open position.
- Activating CLOSE input will cause valve to travel to full close position.
- Activating STOP input while valve is moving will stop valve.

6.0 AUTOMATIC WATER DRAIN VALVE



Injury or death may occur by attempting to use a damaged Valve Under Monitor or Valve Under Monitor RC. Before using the valve inspect it for damage resulting from:

- **Exposure to temperatures in excess of 160 degrees F**
- **Missing parts, physical abuse**
- **Failure to drain valve followed by exposure to freezing conditions.**

If the VUM is equipped with an automatic drain valve, the monitor will drain following use to the extent allowable by gravity, the monitor's orientation and its geometry. The drain valve, located in the half ball, is designed to close automatically when pressure exceeds 5 psi. When pressure drops below 5 psi, the drain valve will open. This is dependent on proper assembly, which should be verified visually and functionally prior to fire ground use.

When the automatic drain valve is not desired, it may be disabled. This does not prevent the drain valve from being enabled in the future if desired. Referring to the exploded view in section 7.0, follow the steps below:

1. Remove the screw and washers from inside of half ball (index # 3, 5 & 6). Index #3 may not be present .
2. To disable, flip rubber drain valve (index # 4) so that raised edge is against flat face of half ball.
To enable, flip rubber drain valve (index # 4) so that raised edge is away from flat face of half ball.
3. Reassemble. If a stump is not visible on flat face of half ball, install shoulder washer (index #3) first.

The automatic drain valve may also be omitted at the time of order by customer request. When the automatic drain valve is omitted or disabled, the main valve must be manually to allow drainage when exposed to freezing conditions.

7.0 DRAWINGS AND PARTS LISTS

Worm Drive Gearbox, Parallel Drive Gearbox
And RC Motor Assembly shown on following pages

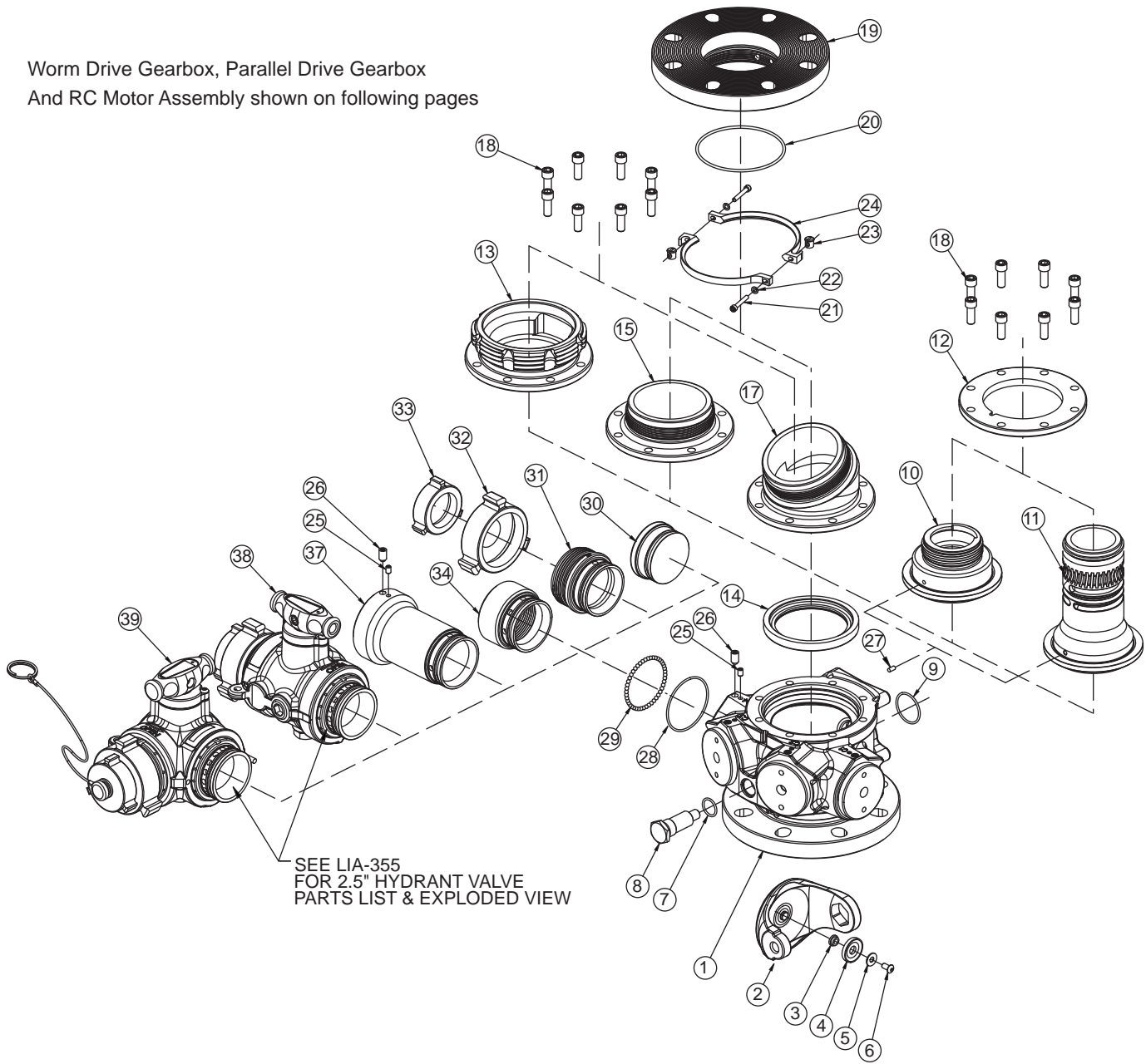

Figure 7.0a
Exploded View Without Gearbox

7.0 DRAWINGS AND PARTS LISTS

MAIN BODY

INDEX	DESCRIPTION	QTY	ITEM #
1	VUM BODY	1	A1025
2	HALF BALL SELF-DRAIN	1	A1028
3	SHOULDER WASHER FOR HALF BALL	1	A1029
4	DRAIN VALVE	1	X382
5	SS FLAT WASHER 1/4"	1	VW687X281-50
6	1/4-28 X 1/2 BUTTON HEAD SCREW	1	VT25-28BH500
7	O-RING-117	1	VO-117
8	TRUNNION VUM LOWER	1	A1027
9	O-RING-128	1	VO-128

MONITOR OUTLET OPTIONS

INDEX	DESCRIPTION	QTY	PART #
10	QUICK CONNECT - VUM X 2.5"NHM	1	Y2432A
11	TORNADO TILLER BASE FOR VUM	1	Y2414A
	TORNADO RC BASE FOR VUM		Y2416A
12	FLANGE VUM FOR SMALL MONITORS	1	Y2433
13	QUICK CONNECT - VUM X 4.5"NHM	1	Y4484
14	VALVE SEAT BIV	1	A1520
15	OUTLET VUM CODE-RPM	1	A1026
17	OUTLET VUM 22.5 DEGREE	1	A1040
18	3/8-16 X 1 SOCKET HEAD SCREW	8	VT37-16SH1.0
19	FLANGE CODE-RPF X 4"ANSI 150	1	A1039
20	O-RING-244	1	VO-244
21	10-32 X 1.1 SOCKET HEAD CAP SCREW	2	VT10-32SH1.2
22	WASHER	2	VW360X200-04
23	CYLINDER NUT	2	Y4437
24	4" MONITOR BASE CLAMP	2	Y4435
27	3/16 X 3/8 HDP SPIROL PIN	1	VP188X.38HDP

AUXILIARY PORT OPTIONS

(QTY PER PORT)

INDEX	DESCRIPTION	QTY	PART #
25	1/4-28 X 3/8 SOCKET SET SCREW	1	VT25-28SS375
26	3/8-24 X 3/8 DOG POINT	1	H515
28	O-RING-148	1	VO-148
29	3/16" SS BALL	46	V2120
30	PLUG HSBGM275	1	A1031
31	OUTLET HSBGM275 X 2.5"NHM	1	A1033NJ
	OUTLET HSBGM275 X 2.5"NPTM	1	A1033TJ
32	ADAPTER 2.5"NHF X 1.5"NHM ROCKERLUG	1	P411NJNF
33	BLIND CAP 1.5"NHF W/ 18" LANYARD	1	P412NF
34	OUTLET HSBGM275 X 2.5"NPTF	1	A1035TJ
37	EXTENSION TUBE 4.75" LONG	1	A1032
38	VALVE STRAIGHT 2.5"NHM - SUBASSEMBLY	1	AV5VUM-NJ
39	GATED ELBOW LEFT 2.5"NHM - SUBASSEMBLY	1	AV5LVUM-NJ
	GATED ELBOW RIGHT 2.5"NHM - SUBASSEMBLY	1	AV5RVUM-NJ

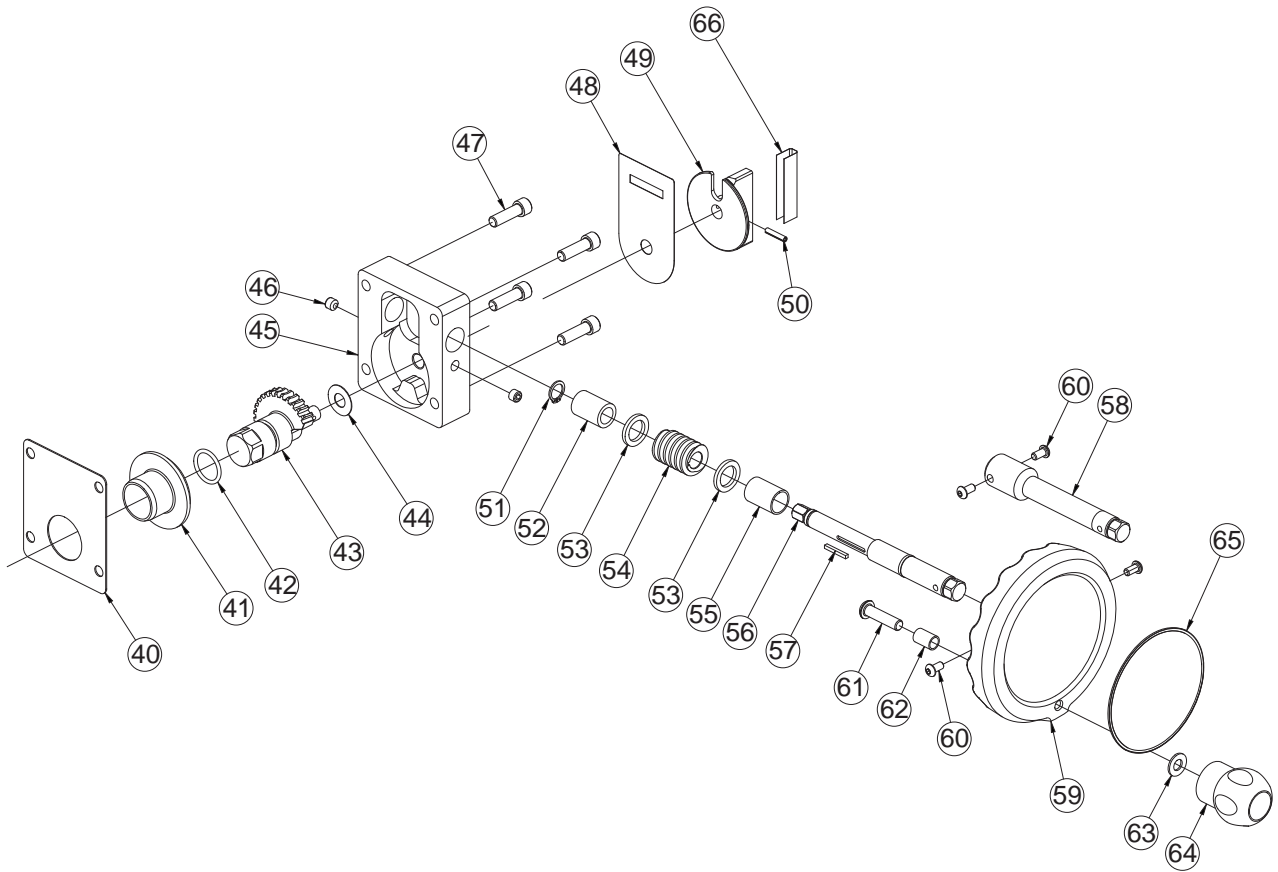

Figure 7.0b
Exploded View of Worm Drive Gearbox

WORM DRIVE GEARBOX

INDEX	DESCRIPTION	QTY	ITEM #
40	GEARBOX COVER	1	A1030
41	GEAR SPACER	1	A1511
42	O-RING-214	1	VO-214
43	INTEGRAL WORM GEAR & TRUNNION	1	A1501
44	GEAR THRUST WASHER	1	A1502
45	GEARBOX 250PSI	1	A1506
46	3/8-16 X 5/16 SOCKET SET SCREW	2	VT37-16SS312
47	3/8-16 X 1 1/4 SOCKET HEAD SCREW	4	VT37-16SH1.2
48	NAME LABEL: VUM GEARBOX	1	A1024
49	POSITION INDICATOR	1	A1523
50	5/32 X 7/8 HDP SPIROL PIN	1	V1900
51	RETAINING RING 15 MM EXTERNAL STAINLESS	1	VR4275
52	SMALL BUSHING	1	A1525
53	THIN WASHER	2	A1530
54	12 DP WORM - DEGREASED	1	X220
55	LARGE BUSHING	1	A1526
56	CRANK SHAFT	1	A1510
57	KEY	1	X225
58	EXTENSION 4"LONG FOR CRANK SHAFT	1	1037
59	HANDWHEEL	1	X281
60	1/4-20 X 1/2 BUTTON HEAD SCREW	2	VT25-20BH500
61	3/8-16 X 1-1/2 BUTTON HEAD SCREW	1	VT37-16BH1.5
62	CRANK BUSHING	1	A1513
63	WASHER	1	VWB12X406-65
64	KNOB	1	A1512
65	HANDWHEEL LABEL	1	A1306
66	POSITION INDICATOR LABEL	1	A1524

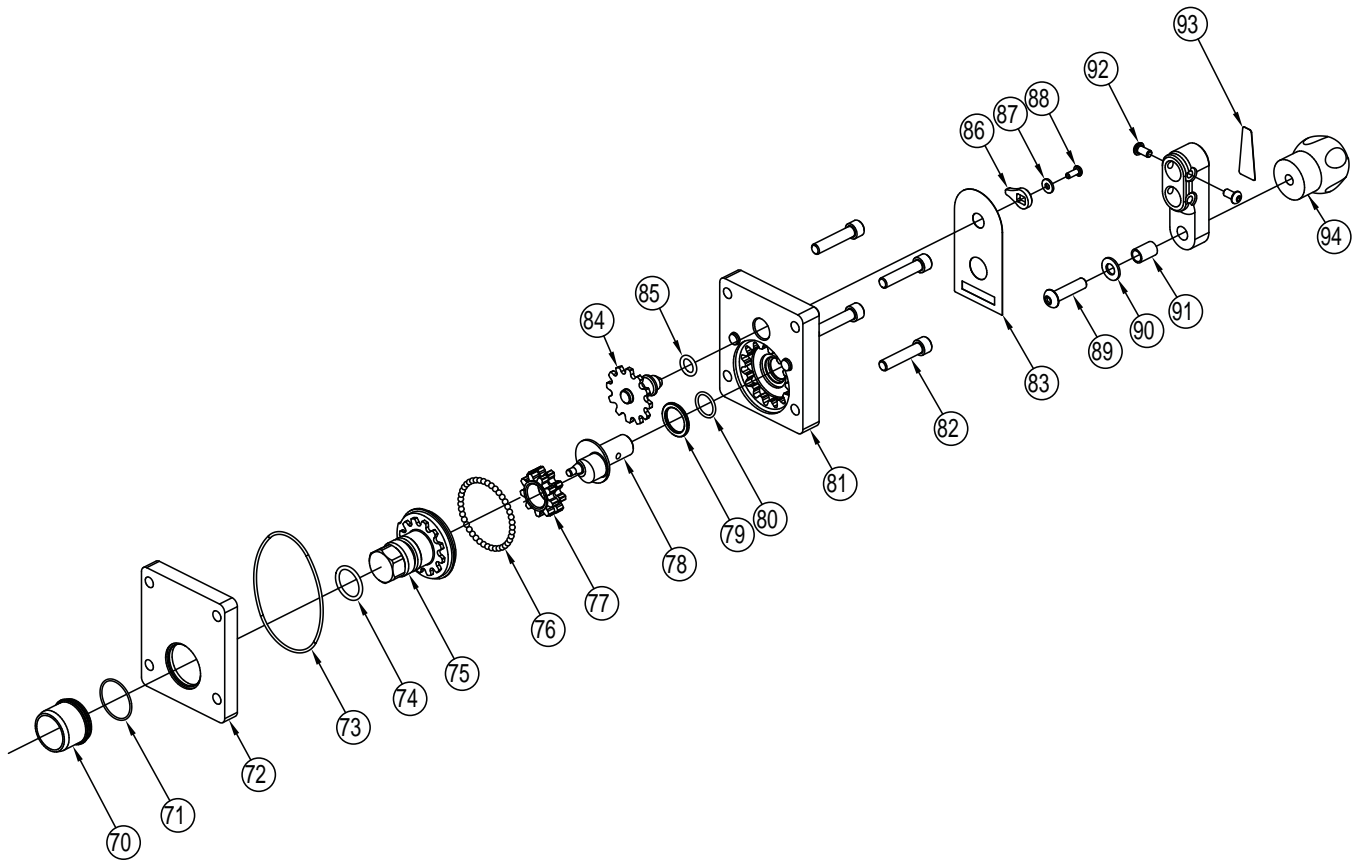

Figure 7.0c
Exploded View of Parallel Drive Gearbox

PARALLEL DRIVE GEARBOX

INDEX	DESCRIPTION	QTY	ITEM #
70	INNER BUSHING	1	A1552
71	O-RING-132 1-3/4" ID 3/32" C/S	1	VO-132
72	SUBPLATE	1	A1551
73	O-RING-174 3-3/4" ID 3/32" C/S	1	VO-154
74	O-RING-214 1" ID 1/8" C/S	1	VO-214
75	INNER TRUNNION	1	A1553
76	3/16" BALL	41	V2120
77	DOUBLE GEAR	1	A1554
78	DRIVE SHAFT	1	A1555
79	SPACER	1	A1556
80	O-RING-116 3/4" ID 3/32" C/S	1	VO-116
81	GEAR BOX	1	A1550
82	3/8-16 X 1-1/2" SOCKET HEAD CAP SCREW	4	VT37-16SH1.5
83	VALVE UNDER MONITOR NAME LABEL	1	A1551L
84	INDICATOR GEAR	1	A1557
85	O-RING-206 1/2" ID 1/8" C/S	1	VO-206
86	POSITION INDICATOR	1	A1558
87	WASHER	1	VW500X203-60
88	10-32 X 3/8" BUTTON HEAD CAP SCREW	1	VT10-32BH375
89	3/8-16 X 1-1/2" BUTTON HEAD CAP SCREW	1	VT37-16BH1.5
90	WASHER	1	VW812X406-65
91	CRANK BUSHING	1	A1513
92	1/4-20 X 1/2" BUTTON HEAD CAP SCREW	2	VT25-20BH500
93	FOLDING HANDLE LABEL	1	AY342
94	KNOB	1	A1512

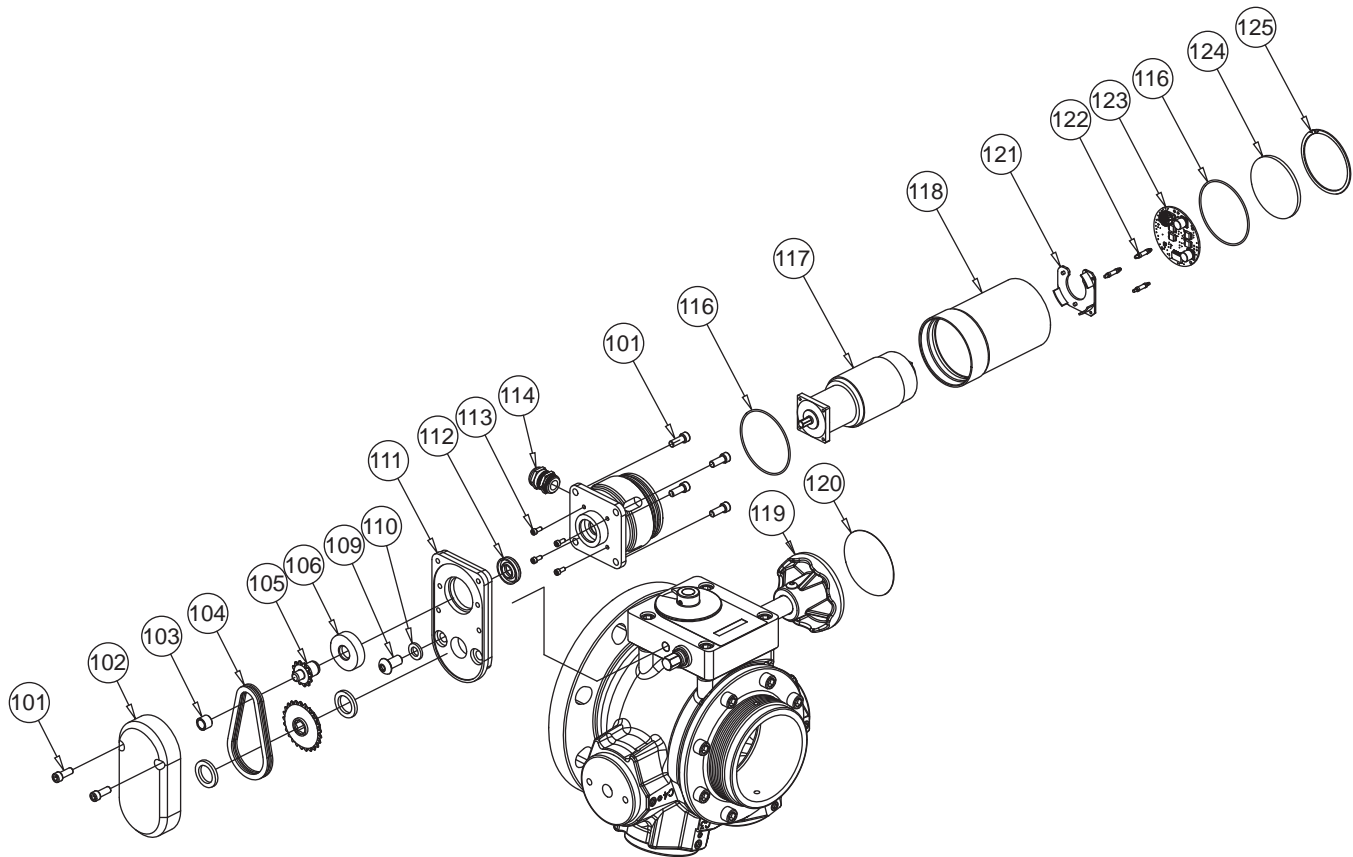

Figure 7.0d
Exploded View of RC Motor Assembly for Valve Under Monitor RC

RC MOTOR ASSEMBLY

INDEX	DESCRIPTION	QTY	ITEM #
101	1/4-28 X 5/8 SOCKET HEAD SCREW	6	VT25-28SH625
102	REDUCER COVER	1	A1097
103	BUSHING NYLON 3/8 X 1/2 X 3/8	1	X252
104	38LINK ROLLER CHAIN S.S. - SUBASSEMBLY	1	AX1685
105	DRIVE SPROCKET	1	X253
106	BUSHING MOTOR	1	X256
107	THIN WASHER	2	A1530
108	BIV SPROCKET 25	1	A1098
109	3/8-16 X 3/4 BUTTON HEAD SCREW	1	VT37-16BH750
110	LOCK WASHER 3/8" STAINLESS 18-8	1	VW375SSLOCK
111	REDUCER HOUSING	1	A1096
112	CUP SEAL 1.0625 X .5625 X 1/4	1	Y4620
113	6-32 X 5/16 LONG SHCS WITH HEAD SEAL	4	VT06S32SH312
114	STRAIN RELIEF PG11 .39 HOLE	1	Y5205
115	MOTOR SOCKET	1	Y4615
116	O-RING-038	2	VO-038
117	GEAR MOTOR	1	Y4600
118	MOTOR ENCLOSURE TUBE	1	Y4641
119	KNOB	1	Z245
120	OVERRIDE KNOB LABEL	1	Y4176
121	MOTOR BOARD SUPPORT	1	Y4643
122	CIRCUIT BOARD STANDOFF	3	Y5538
123	VALVE MOTOR BOARD	1	A5825
124	MOTOR ENCLOSURE CAP	1	Y4642
125	SMALLEY RING	1	V4295

8.0 TROUBLE SHOOTING

SYMPTOM	POSSIBLE CAUSE	REMEDY
Leaks	Debris or damage in seal area	Clean out debris or replace damaged parts
Binding, Erratic operation	Low Voltage (see below)	See Below
Power LED on but no operation	Low voltage due to: -wire gage too small -wire length too long -poor connection -inadequate apparatus electrical system	Check connections and wiring per section 4.4
LED D6 on motor board blinks rapidly when button is pressed	Bad motor encoder	Replace motor sub assembly
No Power LED	Polarity reversed or poor connection	Check wiring and correct polarity
Valve operates from valve control but not from RC monitor operator stations	Incorrect communication wiring	Check blue & white communication wiring

9.0 MAINTENANCE

This valve should be disconnected, cleaned and visually inspected inside and out at least twice annually, or as water quality and use may require. Moving parts such as hand wheels, valve ball and couplings should be checked for smooth and free operation. Seals shall be greased as needed with a silicone-based grease such as Dow Corning 112. Any scrapes that expose bare aluminum should be cleaned and touched up with enamel paint such as Rust-Oleum. If the valve seat is replaced, eight socket head cap screws on the valve seat retainer must be coated with Loctite #242 (blue) and torqued to 180 to 200 in-lbs (15 to 17 ft-lbs). Replace any missing or damaged parts before returning valve to service.



Applying greater than 200 in-lbs (17 ft-lbs) torque to valve seat retainer screws may damage the valve body. Injury could result from use after damaging the valve body.



Dissimilar metals coupled together can cause galvanic corrosion that can result in the inability to unscrew the threads of complete loss of thread engagement over time. Per NFPA 1962 (1998 edition), if dissimilar metals are left coupled together an anti-corrosive lubricant should be applied to the threads. Also the coupling should be disconnected and inspected at least quarterly.



Any alterations to the Valve Under Monitor and its markings could diminish safety and constitutes a misuse of this product.

10.0 PRESSURE LOSS

VALVE UNDER MONITOR PRESSURE LOSS

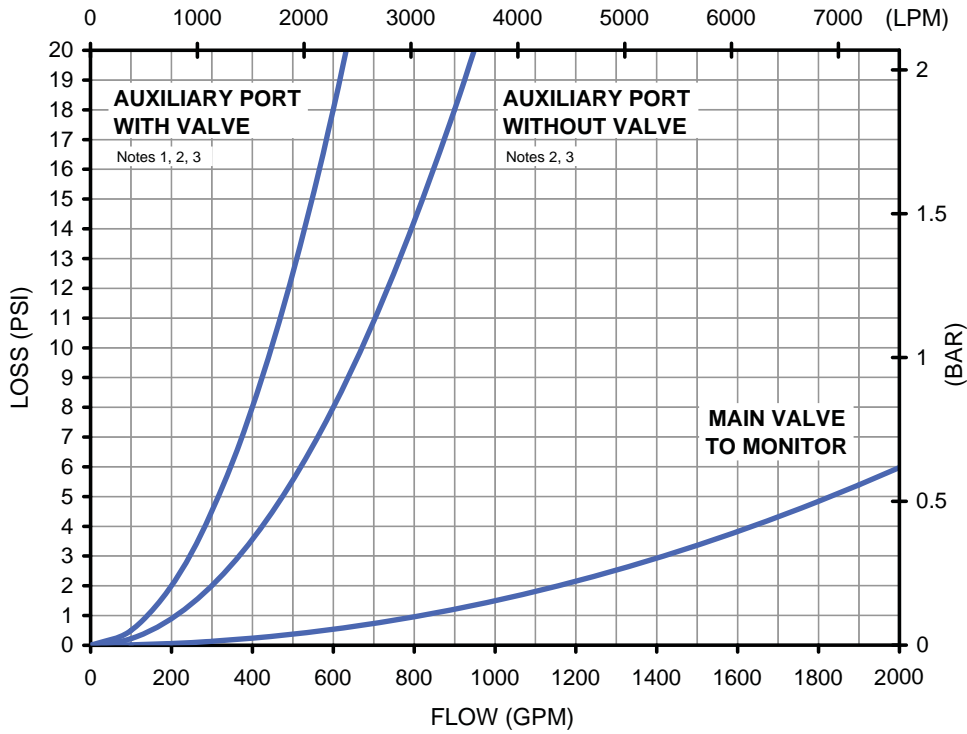

NOTES:

- 1) Curve represents auxiliary port options 2 and 3 (gated elbows). Pressure loss for auxiliary port option 4 (straight hydrant valve) is about 15% less than indicated.
- 2) When valve to monitor is open, pressure loss through auxiliary ports C3 and C4 may be up to 50% greater than indicated. Auxiliary ports C1 and C2 are not affected by this condition.
- 3) Extension pipes (auxiliary port options B through F) do not add significant pressure loss.

11.0 TEMPLATES

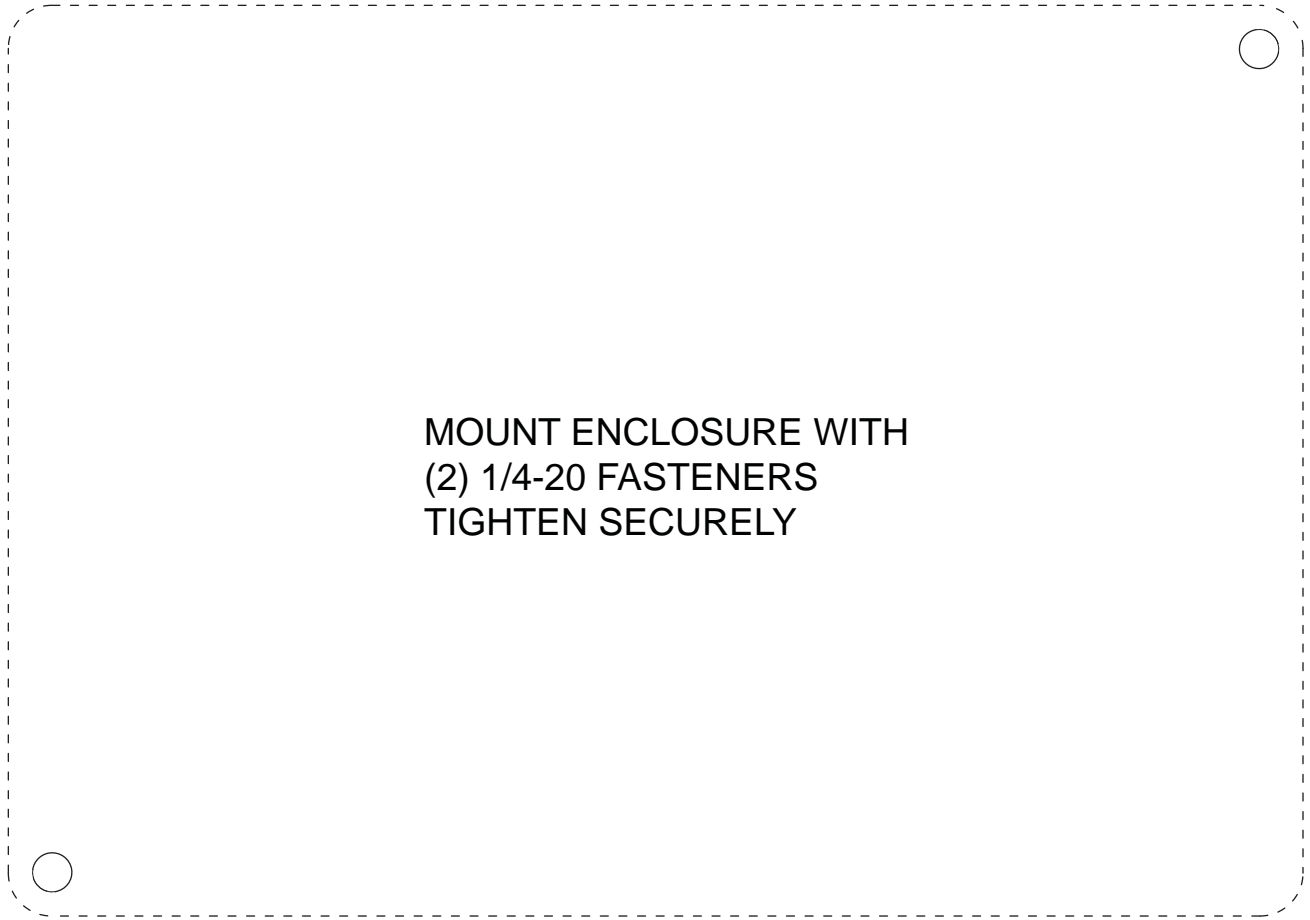

Hole Location for Enclosure

12.0 WARRANTY

Task Force Tips, Inc., 3701 Innovation Way, Valparaiso, Indiana 46383-9327 ("TFT") warrants to the original purchaser of its Valve Under Monitor and Valve Under Monitor RC ("equipment"), and to anyone to whom it is transferred, that the equipment shall be free from defects in material and workmanship during the five (5) year period from the date of purchase.

TFT's obligation under this warranty is specifically limited to replacing or repairing the equipment (or its parts) which are shown by TFT's examination to be in a defective condition attributable to TFT. To qualify for this limited warranty, the claimant must return the equipment to TFT, at 3701 Innovation Way, Valparaiso, Indiana 46383-9327, within a reasonable time after discovery of the defect. TFT will examine the equipment. If TFT determines that there is a defect attributable to it, TFT will correct the problem within a reasonable time. If the equipment is covered by this limited warranty, TFT will assume the expenses of repair.

If any defect attributable to TFT under this limited warranty cannot be reasonably cured by repair or replacement, TFT may elect to refund the purchase price of the equipment, less reasonable depreciation, in complete discharge of its obligations under this limited warranty. If TFT makes this election, claimant shall return the equipment to TFT free and clear of any liens and encumbrances.

This is a limited warranty. The original purchaser of the equipment, any person to whom it is transferred, and any person who is an intended or unintended beneficiary of the equipment, shall not be entitled to recover from TFT any consequential or incidental damages for injury to person and/or property resulting from any defective equipment manufactured or assembled by TFT. It is agreed and understood that the price stated for the equipment is in part consideration for limiting TFT's liability. Some states do not allow the exclusion or limitation of incidental or consequential damages, so the above may not apply to you.

TFT shall have no obligation under this limited warranty if the equipment is, or has been, misused or neglected (including failure to provide reasonable maintenance) or if there have been accidents to the equipment or if it has been repaired or altered by someone else.

THIS IS A LIMITED EXPRESS WARRANTY ONLY. TFT EXPRESSLY DISCLAIMS WITH RESPECT TO THE EQUIPMENT ALL IMPLIED WARRANTIES OF MERCHANTABILITY AND ALL IMPLIED WARRANTIES OF FITNESS FOR A PARTICULAR PURPOSE. THERE IS NO WARRANTY OF ANY NATURE MADE BY TFT BEYOND THAT STATED IN THIS DOCUMENT.

This limited warranty gives you specific legal rights, and you may also have other rights which vary from state to state.