



MANUAL:

Ball Intake Valve
Ball Intake Valve RC
Jumbo Ball Intake Valve
Jumbo Ball Intake Valve RC

INSTRUCTIONS FOR INSTALLATION, SAFE OPERATION AND MAINTENANCE



WARNING Read instruction manual before use. Operation of this device without understanding the manual and receiving proper training can be dangerous and is a misuse of this equipment. Call 800-348-2686 with any questions.

This instruction manual is intended to familiarize firefighters and maintenance personnel with the operation, servicing and safety procedures associated with the Ball Intake Valve Series.

This manual should be kept available to all operating and maintenance personnel.

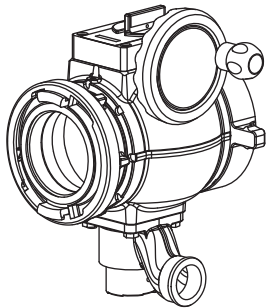

Ball Intake Valve
AP & AQ Series

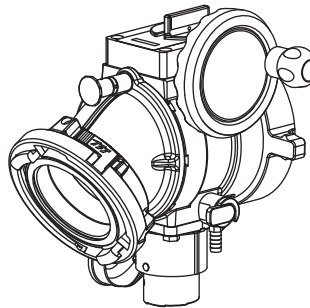

Ball Intake Valve

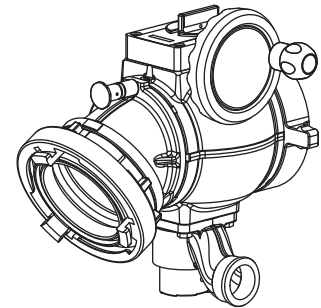

Jumbo Ball Intake Valve

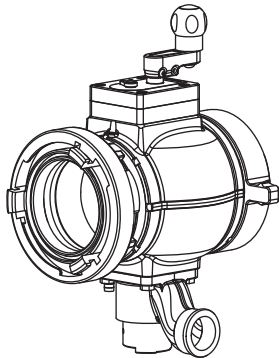

Ball Intake Valve
AP & AQ Series
With Parallel Shaft

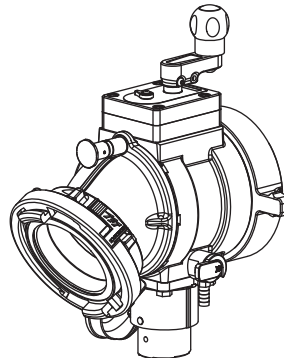

Ball Intake Valve
With Parallel Shaft

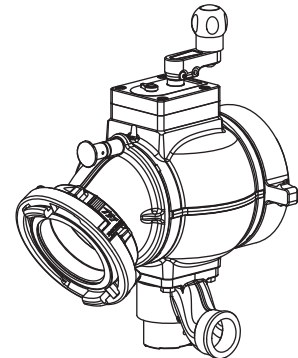

Jumbo Ball Intake Valve
With Parallel Shaft

OPERATING RANGE:
 Pressure Max 250 PSI (17 bar)
 Pressure Min Full Vac.

**Hydrostatic
 Proof Test:**
 900 PSI (62 bar)

**Six seconds from
 open to close
 meets NFPA 1901
 slow close requirement.**

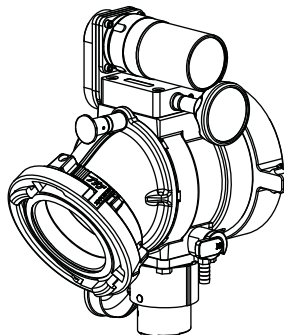

Ball Intake Valve RC

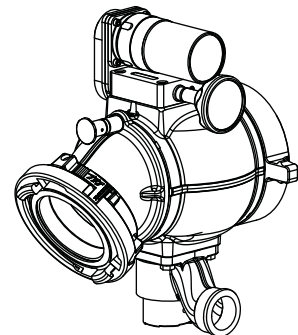

Jumbo Ball Intake Valve RC

TASK FORCE TIPS, INC.
 MADE IN USA • www.tft.com

3701 Innovation Way, Valparaiso, IN 46383-9327 USA
 800-348-2686 • 219- 462-6161 • Fax 219-464-7155

Table Of Contents

- 1.0 MEANING OF SIGNAL WORDS
- 2.0 SAFETY
- 3.0 GENERAL INFORMATION
 - 3.1 SPECIFICATIONS
 - 3.2 CORROSION
 - 3.3 USE WITH SALT WATER
- 4.0 INSTALLATION
 - 4.1 MOUNTING ON TRUCK
 - 4.2 ENCLOSURE MOUNTING
 - 4.3 ELECTRICAL INSTALLATION AND WIRING
 - 4.4 ELECTRICAL TESTING
 - 4.5 CHANGING HANDWHEEL TO LEFT SIDE (NON RC MODELS)
 - 4.6 CHANGING HANDWHEEL TO LEFT SIDE (RC MODELS)
 - 4.7 BALL INTAKE VALVE RC MANUAL OVERRIDE
 - 4.8 CHANGING OFFSET OF CRANK HANDLE
 - 4.9 CHANGING THE COUPLING LOCKOUT
- 5.0 USE
 - 5.1 INTAKE ELBOW
 - 5.2 VALVE POSITION INDICATOR
 - 5.3 STORZ SUCTION GASKET REQUEST
 - 5.4 BALL INTAKE VALVE RC OPERATION
 - 5.5 SUCTION SCREEN
- 6.0 AIR VENT AND WATER DRAIN
- 7.0 PRESSURE RELIEF VALVE
 - 7.1 SETTING PRESSURE
 - 7.2 FLOW vs. PRESSURE CURVE
- 8.0 DRAWINGS AND PARTS LISTS
- 9.0 TROUBLE SHOOTING
- 10.0 MAINTENANCE
- 11.0 BALL INTAKE VALVE PRESSURE LOSS
- 12.0 TEMPLATES
- 13.0 WARRANTY
- 14.0 ANSWERS TO YOUR QUESTIONS



PERSONAL RESPONSIBILITY CODE

The member companies of FEMSA that provide emergency response equipment and services want responders to know and understand the following:

1. Firefighting and Emergency Response are inherently dangerous activities requiring proper training in their hazards and the use of extreme caution at all times.
2. It is your responsibility to read and understand any user's instructions, including purpose and limitations, provided with any piece of equipment you may be called upon to use.
3. It is your responsibility to know that you have been properly trained in Firefighting and /or Emergency Response and in the use, precautions, and care of any equipment you may be called upon to use.
4. It is your responsibility to be in proper physical condition and to maintain the personal skill level required to operate any equipment you may be called upon to use.
5. It is your responsibility to know that your equipment is in operable condition and has been maintained in accordance with the manufacturer's instructions.
6. Failure to follow these guidelines may result in death, burns or other severe injury.



Fire and Emergency Manufacturers and Service Association
P.O. Box 147, Lynnfield, MA 01940 • www.FEMSA.org

1.0 MEANING OF SIGNAL WORDS

A safety related message is identified by a safety alert symbol and a signal word to indicate the level of risk involved with a particular hazard. Per ANSI standard Z535.6-2006, the definitions of the four signal words are as follows:



DANGER indicates a hazardous situation which, if not avoided, will result in death or serious injury.



WARNING indicates a hazardous situation which, if not avoided, could result in death or serious injury.



CAUTION indicates a potentially hazardous situation which, if not avoided, may result in minor or moderate injury.



NOTICE is used to address practices not related to personal injury.

2.0 SAFETY



Do not use AC current to operate the Ball Intake Valve RC or the Jumbo Ball Intake Valve RC. The Ball Intake Valve RC and the Jumbo Ball Intake Valve RC are 12 or 24VDC systems ONLY! Using the wrong power source could cause electrocution, resulting in death or serious injury.



Injury or death can result from burst hoses and fittings. Be sure the pressure relief valve is set at the proper pressure for the type of hose and equipment you are using. See NFPA 1961 and NFPA 1962.



Injury or death may occur by attempting to use a damaged Ball Intake Valve. Before using the valve inspect it for damage resulting from:

- Failure to drain valve followed by exposure to freezing conditions
- Exposure to temperatures in excess of 160 degrees F
- Missing parts, physical abuse



This equipment is intended for use by trained personnel for firefighting. Its use for other purposes may involve hazards not addressed by this manual. See appropriate guidance and training to reduce risk of injury.



Kinks in supply hose may reduce water flow and cause injury or death to persons dependant on water flow. When this valve is used on a hydrant or fire truck it is recommended that it be used with an elbow to minimize risk of hoseline kinks.



The electric Ball Intake Valve RC and the Jumbo Ball Intake Valve RC may be remotely operated. The electric drives are current limited but may still produce enough force to cause injury. Keep hands and fingers away from pinch points on the valve.



Do not use the manual override hand wheel while the electric controls are in operation. The electric drives produce enough torque to cause injury.



The Ball Intake Valve RC and the Jumbo Ball Intake Valve RC have current limiting capabilities which stops the motor if an obstruction is encountered. The Ball Intake Valve RC and the Jumbo Ball Intake Valve RC must be installed as instructed using the correct controls and electrical boxes. Failure to do so will result in damage to the electric motor and loss of current limiting controls. This may result in injury.



Maximum operating pressure 250 PSI (17 bar). Do not exceed 250 PSI on either side of the valve.



Valve must be properly connected. Mismatched or damaged connectors may cause leaking or uncoupling under pressure and could cause injury.



The Ball Intake Valve may become damaged if it is allowed to freeze while containing water. Always drain after use to avoid damage and possible loss of use.

3.0 GENERAL INFORMATION

The Ball Intake Valve and the Jumbo Ball Intake Valve are intended for use on the intake manifold of a fire engine. The valve is kept closed while the water supply from a hydrant or another pumper to the engine is being established. This prevents the pump from sucking air through the intake manifold and losing its prime. Once the supply hose is filled and under pressure, and the air has been vented from the hose, the valve may be opened to connect the pump to the water supply. An adjustable pressure relief valve mounted on the bottom of the valve opens to relieve any excess pressure that may damage the hose or the pump. An electric remote controlled (RC) model allows the valve to be operated from a remote location. A typical installation will consist of the BIV RC and a remote display operator station. Motor controls are designed to auto sense 12 VDC or 24 VDC operation. The motor control circuit utilizes a position encoder and current limiting to protect the drive train at the ends of travel. Unit is supplied with 2' of cable with a plug on BIV RC and 10' of cable with a receptacle so installation effort is minimized. Cable has only four conductors (two for power and two for communications) further easing installation effort. To complete the installation, the installer will need to mount and wire the remote display operator station. The power supply for the BIV RC will need to be connected to a protected circuit from the trucks power distribution center. Refer to the specifications section 3.1 for nominal current draw.

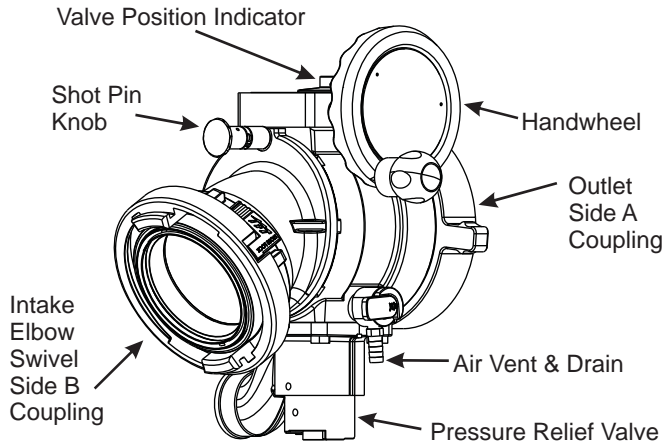

AB1ST-NX
Ball Intake Valve w/Pressure Relief Valve

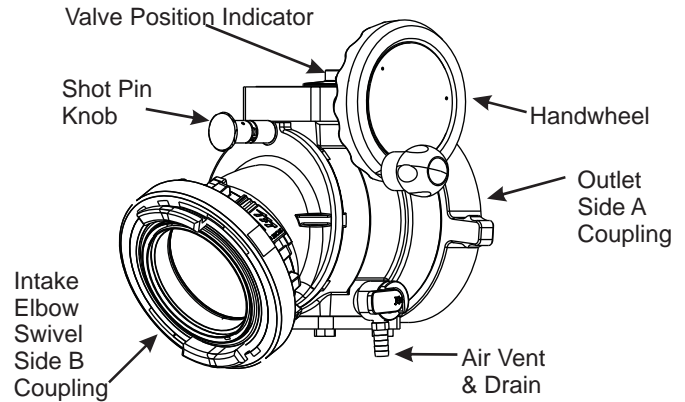

AC1ST-NX
Ball Intake Valve

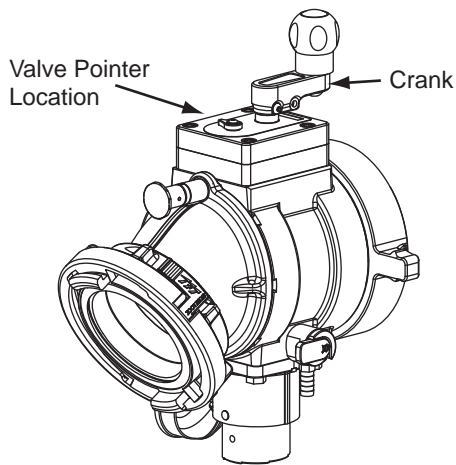

AB1ST-NX-PS
Ball Intake Valve With Parallel Shaft

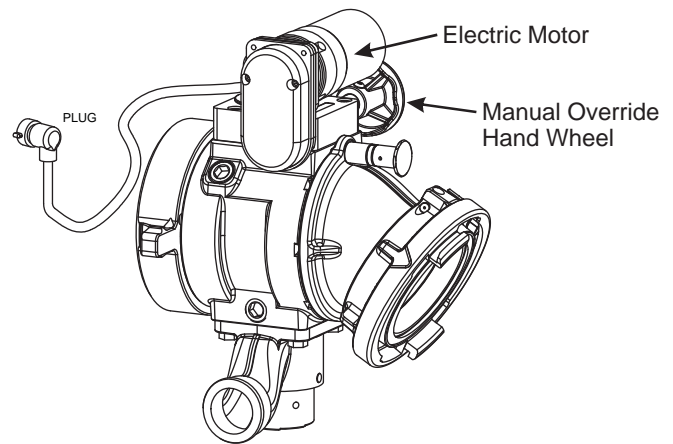

AB1ST-NX-RC
Ball Intake Valve RC

3.1 SPECIFICATIONS

MODEL	BALL INTAKE VALVE	JUMBO INTAKE VALVE	BALL INTAKE VALVE RC	JUMBO INTAKE VALVE RC
Waterway Size	3.65" (93mm)	5.25" (133mm)	3.65" (93mm)	5.25" (133mm)
Max Pressure	250 psi (17 bar)	250 psi (17 bar)	250psi (17 bar)	250psi (17 bar)
Min Pressure	Full Vacuum	Full Vacuum	Full Vacuum	Full Vacuum
Opening/Closing Speed			6 sec	6 sec
Voltage - Auto Sense			12 or 24volt DC	12 or 24volt DC
Motor Current (RC Only)			Nominal	
			@ 12 VDC	@ 24 VDC
			3 amp	1.5 amp
Recommended Fuse or Circuit Breaker Size			15 amp@12 Volt	
			7.5 amp @ 24 Volt	
Environmental Rating	All components designed to meet minimum rating of NEMA 4 (IP65)			

3.2 CORROSION

Hose couplings are attached using polymer bearing rings which provides electrical insulation to help prevent galvanic corrosion. The parts are then hard anodized, and finally powder coated, inside and out, to help prevent corrosion. The effects of corrosion can be minimized by good maintenance practice. See section 10.0 for maintenance.

3.3 USE WITH SALT WATER

Use with salt water is permissible provided valve is thoroughly cleaned with fresh water after each use. The service life of the valve may be shortened due to the effects of corrosion and is not covered under warranty.

4.0 INSTALLATION

4.1 MOUNTING ON TRUCK

Screw the large coupling to the pump inlet manifold. The valve position indicator should be clearly visible, but need not be level.

4.2 ENCLOSURE MOUNTING

Select proper location for display. A full size template is shown in section 12.0.

4.3 ELECTRIC INSTALLATION AND WIRING

Red (+) and black (-) wires must be connected to a 12 or 24 VDC protected circuit from the truck's power distribution center. Figure 4.3 shows the control connections.

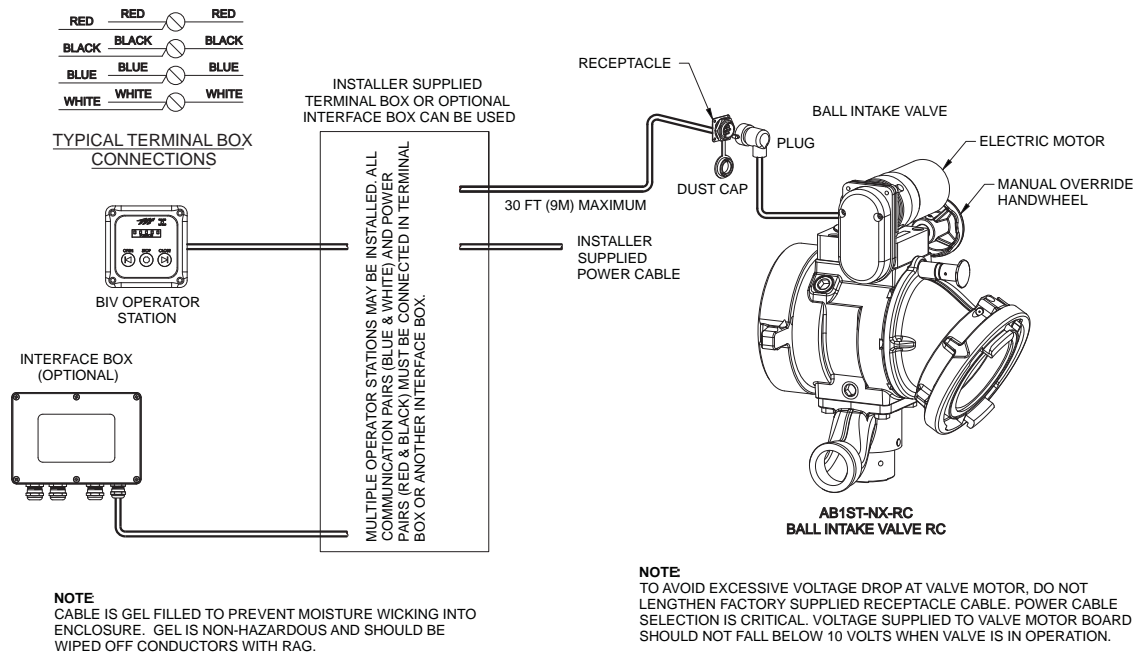

Figure 4.3



The electric motor and other components are ignition sources. The electric BIV should be operated only in areas where there is adequate ventilation and no hazard of flammable vapor buildup.

4.4 ELECTRICAL TESTING

VERIFY PROPER VOLTAGE

The TFT Ball Intake Valve RC has built in circuit protection to guard against a circumstance where the unit's movement is blocked before reaching its full travel limits. Without this circuitry the motor would stall, overheat, and could be permanently damaged.

IMPORTANT - When mechanical installation and electrical connections are complete, perform the following test to verify voltage supply is adequate and the current limiting feature is functioning.

1. Apply power to Valve Control.
2. Press OPEN or CLOSE button and hold until valve reaches stop position. Continue to hold button down.
3. Once movement is stopped, manually turn override knob in opposite direction while continuing to hold button down. If knob can be turned, then voltage supply is adequate. If knob can't be turned and motor continues to operate, then the current limit was not reached because the voltage supply or wiring is not adequate.

NOTE: Override knob will only turn in one direction.

To ensure proper voltage to the Ball Intake Valve RC, the wiring needs to be checked for proper gauge for the installed length of wire, and for proper termination. Also, ensure that the power source supplying the BIV RC and the grounding are adequate (other electrical loads on a shared circuit with the BIV RC may cause a low-voltage situation).

In addition to motor damage, a further consequence of low voltage could be that the valve will not open or close properly or fully.

SET TRAVEL STOPS

When proper voltage is verified, perform the following to set the full travel limits.

1. Apply power to Valve Control.
2. Press CLOSE button and continue to hold until valve is fully closed. Motor must stop by current limit method. If motor continues to operate see proper voltage section above.
3. Press OPEN button and continue to hold until valve is fully open. Motor must stop by current limit method. If motor continues to operate see proper voltage section above.
4. Position indicator lights will now track valve movement.

4.5 CHANGING HANDWHEEL TO LEFT SIDE (NON RC MODELS)

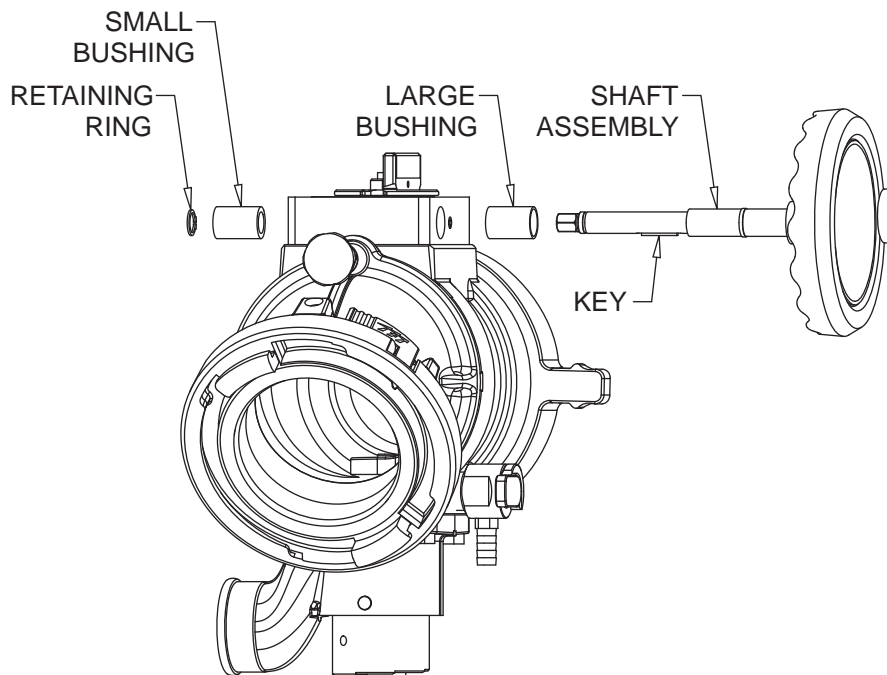

The handwheel is shipped from the factory on the right hand side of the valve. The hand wheel can be switched to the left hand side for convenience or if it interferes with other equipment on the pump panel.

To move the handwheel to the opposite side, remove the retaining ring on the end of the shaft. Pull the shaft out of the gear box. As the shaft is withdrawn, grasp the small key on the shaft so it does not get lost. Remove and switch the two plastic bushings that come out of the sides of the gearbox. The bushing with the large hole is installed on the same side as the handwheel.

Look through the gear box and note approximate position of the keyway in the worm inside the gear box. Slide the shaft into the gearbox on the opposite side of the gear box with the key oriented the same as the keyway. A small dab of grease will keep the key place. Rotate the shaft until the key finds the keyway and push the shaft in until it stops. Reinstall the retaining ring. Do not over expand the retaining ring.

4.6 CHANGING HAND WHEEL TO LEFT SIDE (RC MODELS)

STEP 1: Remove screws and end cover

STEP 2: Slide off both sprockets and chain as one unit.

STEP 3: Remove button head screws and lock washer to remove motor unit.

STEP 4: Remove 4 screws and reposition motor so electric wire points in desired direction.

STEP 5: Change hand wheel to other side as in Section 4.3.

STEP 6: Reverse steps 1, 2 and 3 to reinstall motor on other side.

STEP 7: Reverse polarity (direction) of motor by holding OPEN and CLOSE buttons together for 15 seconds.

NOTE: Remove set screw that is in hole for the button head screw and reinstall the set screw on the other side. The set screw plugs the hole to keep dirt from entering the gearbox.

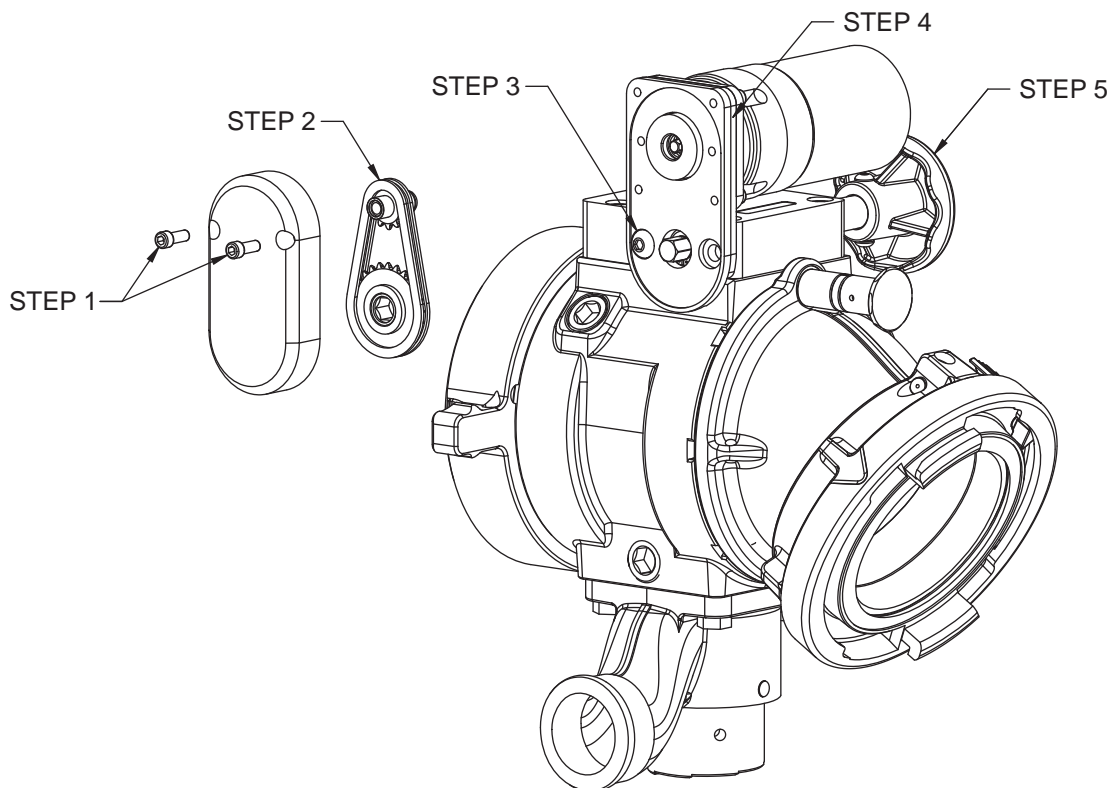

4.7 BALL INTAKE VALVE RC MANUAL OVERRIDE

The Ball Intake Valve RC is motor driven but also has an override handwheel for operating the valve manually. The override handwheel may also be used in the event of power failure. If electrical power is supplied to the control panel then the LED valve position display will track the valve's position as the handwheel is moved. If the handwheel is moved while there is no power to the electric controls then the LED valve position display will be in error when the electric power is reconnected. The LED valve position indicator will self correct the first time the valve is cycled under electric control.

If more compactness is desired the override handwheel may be removed. The drive shaft has a hex so a wrench or socket may be used for manual override. If the manual override handwheel is removed assure that the correct size wrench or socket is available in the event of power failure.

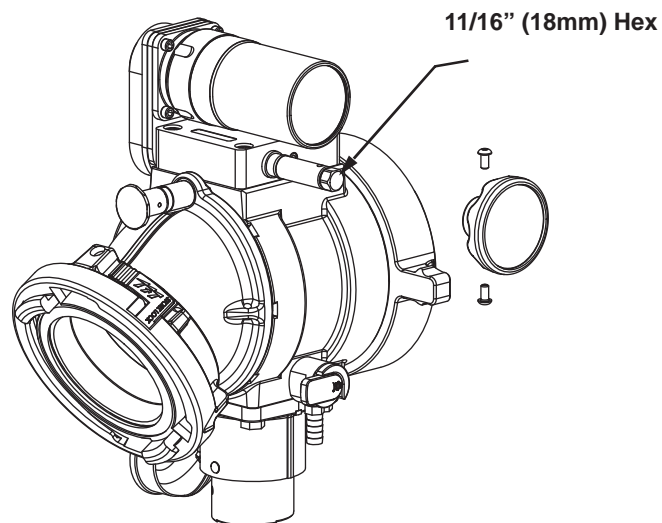

4.8 CHANGING OFFSET OF CRANK HANDLE

When equipped with a crank handle, two offset positions are available to adjust the swing radius of the crank and knob as shown in figure 4.10. The longer offset position offers reduced effort to operate the valve. The shorter offset is available to avoid interference with other equipment on the apparatus. To change the offset, remove two 3/8"-16 x 1-1/2 button head cap screws from crank. Place crank in desired position and replace screws.

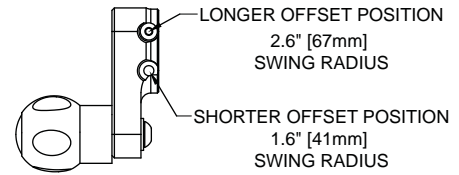

4.9 CHANGING COUPLING LOCK-OUT

To change a coupling from rigid to full time swivel, use a 7/32" Allen driver to back out the lockout screw until the coupling moves freely.

To change a coupling from full time swivel to rigid, first align the pull pin in the elbow to vertical. Rotate the coupling until the lockout screw is aligned with the pull pin. Use a 7/32" Allen driver to tighten the lockout screw into the lockout divot in the elbow.

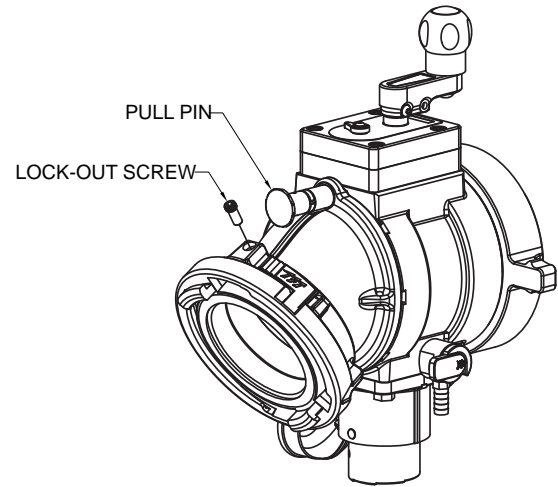

5.0 USE

5.1 INTAKE ELBOW

The intake elbow swivels 360 degrees to help prevent hose kinks, and make connection of suction lines easier. The intake can be turned forward or backward to help make connections in tight places if the water supply is in front of or behind the truck. To turn the elbow, pull the shot pin knob on top of the elbow. The elbow will lock into a detent every 45 degrees. There is a hole on the side of the elbow that can be used to attach the lanyard or chain of a cap by use of a key ring. The elbow may be swivelled to any of eight positions by pulling the shot pin knob.

5.2 VALVE POSITION INDICATOR

To open the valve turn the handwheel until the valve position says "OPEN". To close the valve turn the hand wheel the opposite way until the valve position indicator says "CLOSED".

5.3 STORZ 'SUCTION GASKET' REQUEST

If your application of this product requires drafting, you may need a suction gasket, please call 1-800-348-2686 to receive a free suction gasket by mail.

Part Numbers: 4" STORZ - item # A4216, 5" STORZ - item # A4221

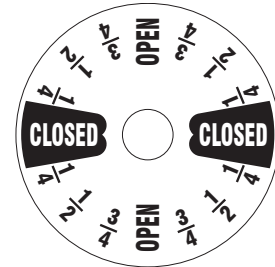

5.4 BALL INTAKE VALVE RC OPERATION

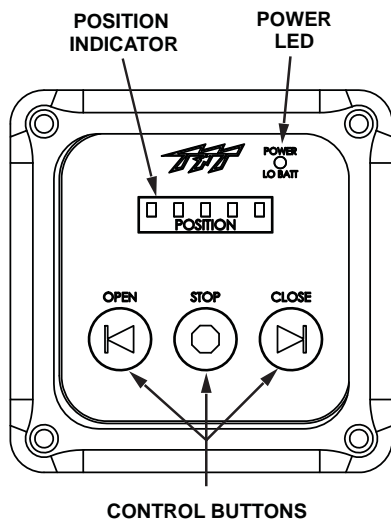

Figure 5.4

Power LED:

LED will be solid green when power is present

Position Indicator:

5 LEDs indicate valve position. One for full close (red at far right), one for full open (green at far left), three yellow for 25%, 50%, and 75% open. Two LEDs will light when position is between two percentages.

Note: The position indicator will lose position if the manual override is used while the power is off. Position location is restored after the first cycle of electric operation.

All 5 position LED's blinking indicates a fault with the motors encoder.

Control Buttons:

Manual Mode

When OPEN or CLOSE button is pressed, valve opens or closes until button is released.

Automatic Mode

When OPEN or CLOSE button is momentarily pressed, valve opens or closes fully.

During valve movement if STOP or the other direction is momentarily pressed the motor will stop.

Changing Modes (Unit is shipped from factory in the Auto Mode)

Press CLOSE and STOP buttons together and hold for 3 seconds to change to Automatic Mode.

Press OPEN and STOP buttons together and hold for 3 seconds to change to manual mode.

5.5 SUCTION SCREEN

This device may be equipped with a suction screen to catch debris larger than 3/8" diameter in the waterway. See chart to determine additional loss caused by the screen. To add or replace a suction screen, order TFT part #A1410-KIT for the 4.5" waterway, and TFT part #1411-KIT for the 5.0" waterway.

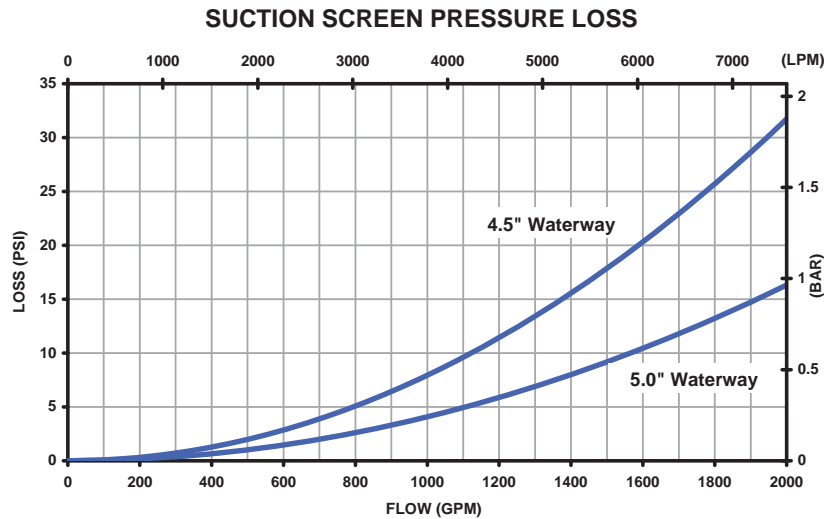

6.0 AIR VENT AND WATER DRAIN

The BIV and Jumbo BIV come with an Air Vent/Drain situated on the side of the PRV pad. The BIV has a second plugged port on the opposite side of the pad. An additional port on both the BIV and Jumbo BIV is located along side of the gearbox. To use a different port position, relocate the factory supplied drain valve or install an additional drain valve. If the Air Vent/Drain is being relocated, use a 3/4" NPT plug to seal the empty port. The barb fitting must be removed from the Air Vent/Drain body to install and replaced once the Air Vent/Drain body is tightened.

7.0 PRESSURE RELIEF VALVE



Loss of prime can interrupt water flow and cause injury or death. Always bleed out air with air valve to prevent possible loss of prime.

If there is a pressure relief valve on the bottom side of the valve. It may be set to any pressure between 50 and 200 psi. Its function is to protect the pump and the supply hose from excess pressure. The relief valve may be mounted with its opening facing the front, back, right or left. A piece of hose or tubing may be mounted on the round spout to direct the water coming out of the relief valve away from the pump panel. To change the orientation of the relief valve, remove the four 7/16 bolts on the corners of the relief valve flange, orient the valve the way you want it, and replace the bolts. Use a drop of thread locking compound on the threads of the bolt to prevent them from coming loose.

7.1 RELIEF VALVE SETTING PRESSURE

To set the relief valve pressure turn the adjusting screw on the relief valve housing until the surface of the screw is even with the desired pressure. Do not cap or plug discharge opening.

7.2 RELIEF VALVE FLOW vs. PRESSURE CURVE

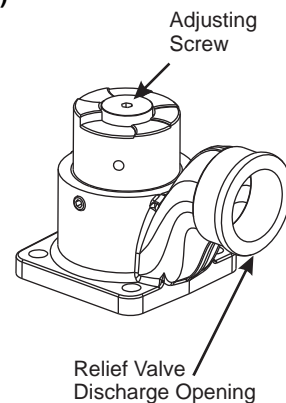
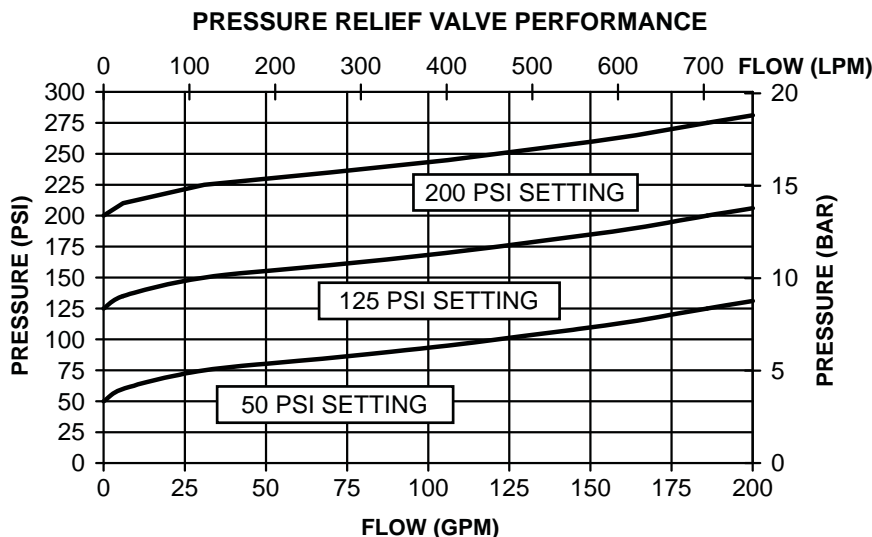

8.0 DRAWINGS AND PARTS LISTS

Ball Intake Valve - AB & AC Series

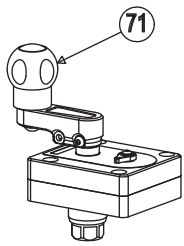

Optional Parallel Shaft Drive

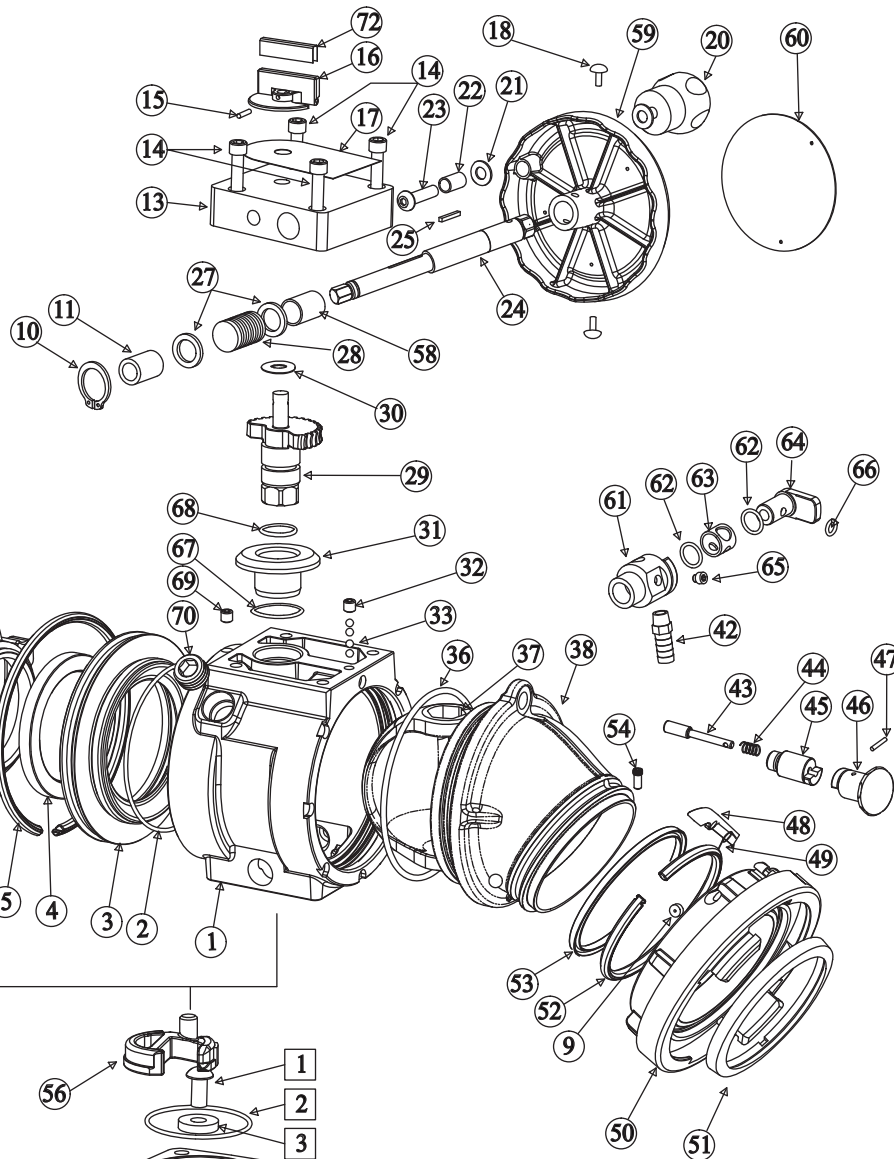

AC Series

○ ≡ Ball Intake Valve Parts List

□ ≡ Relief Valve Parts List

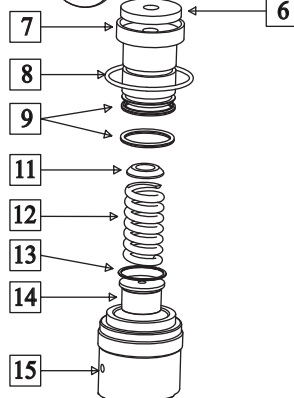
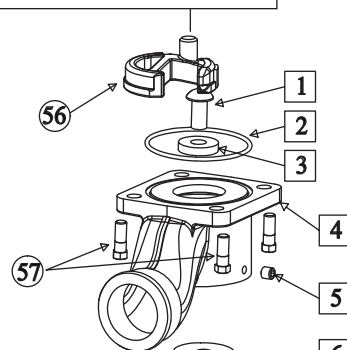

AB Series

RELIEF VALVE PARTS LIST

Index	Description	QTY	Part #
1	1/2-13 X 1.0 BUTTON HEAD CAP SCREW	1	VT50-13BH1.0
2	O-RING-236 3-1/4 ID 1/8 C/S	1	VO-236
3	DEBRIS WASHER	1	A1169
4	HOUSING W/OUT THDS	1	A1150
5	5/16-18 X 3/8 SOCKET SET SCREW CUP POINT	1	VT31-18SS375
6	VALVE SEAT	1	A1168
7	PISTON -HARDCOAT	1	A1160
8	O-RING-231 2-5/8 ID 1/8 C/S	1	VO-231
9	QUAD RING 422 1.5 ID X 1/8 C/S	2	VOQ-422
11	SPRING SEAT	1	A1166
12	RELIEF SPRING	1	A1170
13	SMALLEY RING	1	V4210
14	ADJUSTING SCREW	1	A1167
15	SPRING HOUSING	1	A1164
16	COVER PLATE/CAP	1	X631

8.0 DRAWINGS AND PARTS LISTS

Index	Description	QTY	Part #
1	BIV BODY - POWDER COAT	1	A1015
2	O-RING-236 3-1/4 ID 1/8 C/S	1	VO-236
3	BACK RING STAINLESS STEEL	1	A1201S
4	VALVE SEAT	1	A1520
5	PLASTIC STRIP 7.00"	1	A1290
6	SEAL RETAINER	1	A1521S
7	COUPLING 5.0"NHF X PSF7.0-NFS	1	A1261NT
	COUPLING 6.0"NHF X PSF7.0-NFS	1	A1266NX
8	GASKET - 5.0" HOSE COUPLING	1	V3220
	GASKET - 6.0" HOSE COUPLING	1	V3240
9	PORT PLUG	1	A1299
10	RETAINING RING	1	VR4275
11	SMALL BUSHING	1	A1525
13	GEAR BOX	1	A1505
14	3/8-16 X 1 1/4 SOCKET HEAD CAP SCREW	4	VT37-16SH1.2
15	5/32 X 7/8 HDP SPIROL PIN #12437	1	V1900
16	POSITION INDICATOR	1	A1517
17	LABEL; BGIV GEARBOX	1	AL010
18	BUTTON HEAD SCREW	2	VT25-20BH500
20	KNOB	1	A1512
21	WASHER .812 OD X .406 ID X .065 THICK	2	VW812X406-65
22	CRANK BUSHING	1	A1513
23	3/8-16 X 1.5 BUTTON HEAD CAP SCREW	1	VT37-16BH1.5
24	CRANK SHAFT	1	A1510
25	KEY, 1/8" X 1.00"	1	X225
27	THIN WASHER	2	A1530
28	12 DP WORM	1	X220
29	INTERNAL WORM GEAR TRUNNION	1	A1501
30	GEAR THRUST WASHER	1	A1502
31	GEAR SPACER	1	A1511
32	3/8-16 X 5/16 SOCKET SET SCREW CUP POINT	2	VT37-16SS312
33	1/4" BALL - 302 STAINLESS STEEL	72	V2125
36	CUP SEAL 6.0" ID X 3/16 C/S	1	A1545
37	HALF BALL STAINLESS STEEL	1	A1043S
38	ELBOW 4" (4" STORZ ONLY)	1	A1071
	ELBOW 5"	1	A1054
42	1/2 BARB X 1/4 NPT FITTING	1	XX329
43	DETENT PIN	1	A1560
44	SPRING	1	X345
45	DETENT PIN HOUSING	1	A1570
46	DETENT PIN KNOB	1	A1575
47	SPIROL PIN	1	VP125X750H
48	LOCKING LEVER - MOLDED	1	A4171
49	SPRING TORSION	1	A4230
50	SPOUT 4"NHM X PSF5.25	1	A4620N
	SPOUT 4.5"NHM X PSF5.25	1	A4625N
	SPOUT 5"NHM X PSF5.25	1	A4630N
	COUPLING 4.0"NH X PSF5.25	1	A4660N
	COUPLING 4.5"NH X PSF5.25	1	A4665N
	COUPLING 5.0"NH X PSF5.25	1	A4670N
	COUPLING 6.0"NH X PSF7.0	1	A1266NX
	MATE PSF5.25 X PSM7.0	1	A4745
	PLASTIC STRIP 5.25"	1	A1291
	CUP SEAL 5.25 X 4.750 X 1/4	1	A1596
	LABEL; PORT COVER	1	A1298
	BALL 7/16" STAINLESS	1	VB.437
	COUPLING HEAD STORZ 4" X 4.25PSF	1	A4114
INSERT RING STORZ 4"	1	A4164	
O-RING 155 4" ID X 3/32 C/S	1	VO-155	

Ball Intake Valve Parts List - AB & AC Series

Index	Description	QTY	Part #
50	COUPLING HEAD STORZ 5" X 5.25PSF	1	A4115
	INSERT RING STORZ 5"	1	A4165
	O-RING 250, 5" ID X 1/8 C/S	1	VO-250
	COUPLING HEAD STORZ 6" X 5.25PSF	1	*X696SX-LOCK
	INSERT 6.0"BSPM X PSF5.25	1	A4765
	COUPLING HNDL 4.0"NHF X PSF5.25	1	A4560N
	COUPLING HNDL 4.5"NHF X PSF5.25	1	A4565N
	COUPLING SH 5.0"NHF X PSF7.0 NFS	1	A1261NT
	MATE PSF5.25 X PSM7.0-NFS	1	A4745
	PLASTIC STRIP 5.25"	1	A1291
	CUP SEAL 5.25 X 4.750 X 1/4	1	A1596
	LABEL; PORT COVER	1	A1298
	BALL 7/16" STAINLESS	1	VB.437
COUPLING SH 6.0"NHF X PSF7.0-NFS	1	A1266NX	
MATE PSF5.25 X PSM7.0-NFS	1	A4745	
PLASTIC STRIP 5.25"	1	A1291	
CUP SEAL 5.25 X 4.750 X 1/4	1	A1596	
LABEL; PORT COVER	1	A1298	
BALL 7/16" STAINLESS	1	VB.437	
51	GASKET 4" PRESSURE (4" STORZ ONLY)	1	A4215
	GASKET 4" PRESSURE (4" STORZ ONLY)/VACUUM	1	A4216
	GASKET 5" PRESSURE (5" STORZ ONLY)	1	A4220
	GASKET 5" PRESSURE (5" STORZ ONLY)/VACUUM	1	A4221
	GASKET 6" PRESSURE (6" STORZ ONLY)/VACUUM	1	A4226
	GASKET 4.0" HOSE COUPLING	1	V3198
	GASKET 4.5" HOSE COUPLING	1	V3210
GASKET 5.0" HOSE COUPLING	1	V3220	
GASKET 6.0" HOSE COUPLING	1	V3240	
52	PLASTIC STRIP 4.25" (4" STORZ ONLY)	1	A1292
	PLASTIC STRIP 5.25"	1	A1291
53	CUP SEAL 4.25X3.750 X 1/4 (4" STORZ ONLY)	1	A1597
	CUP SEAL 5.25 X 4.750 X 1/4	1	A1596
54	LOCK-OUT SCREW	1	A1294
56	HOLLOW TRUNNION	1	A1514
57	7/16-14 X 1 HEX HEAD BOLT	4	VT43-14HX1.0
58	LONG BUSHING	1	A1526
59	HANDWHEEL	1	X281
60	NAMEPLATE	1	A1306
61	DRAIN BODY	1	A1543
62	O-RING-115	2	VO-115
63	DRAIN SLEEVE	1	A1541
64	DRAIN LEVER	1	A1542
65	DOG POINT SCREW	1	H515
66	O-RING-110	1	VO-110
67	O-RING-128	1	VO-128
68	O-RING-214	1	VO-214
69	SET SCREW	1	VT31-18SS375
70	3/4"NPTM HEX SOCKET PLUG	1	XG410
71	PARALLEL DRIVE GEARBOX	1	A1633
72	POSITION INDICATOR LABEL	1	A1524

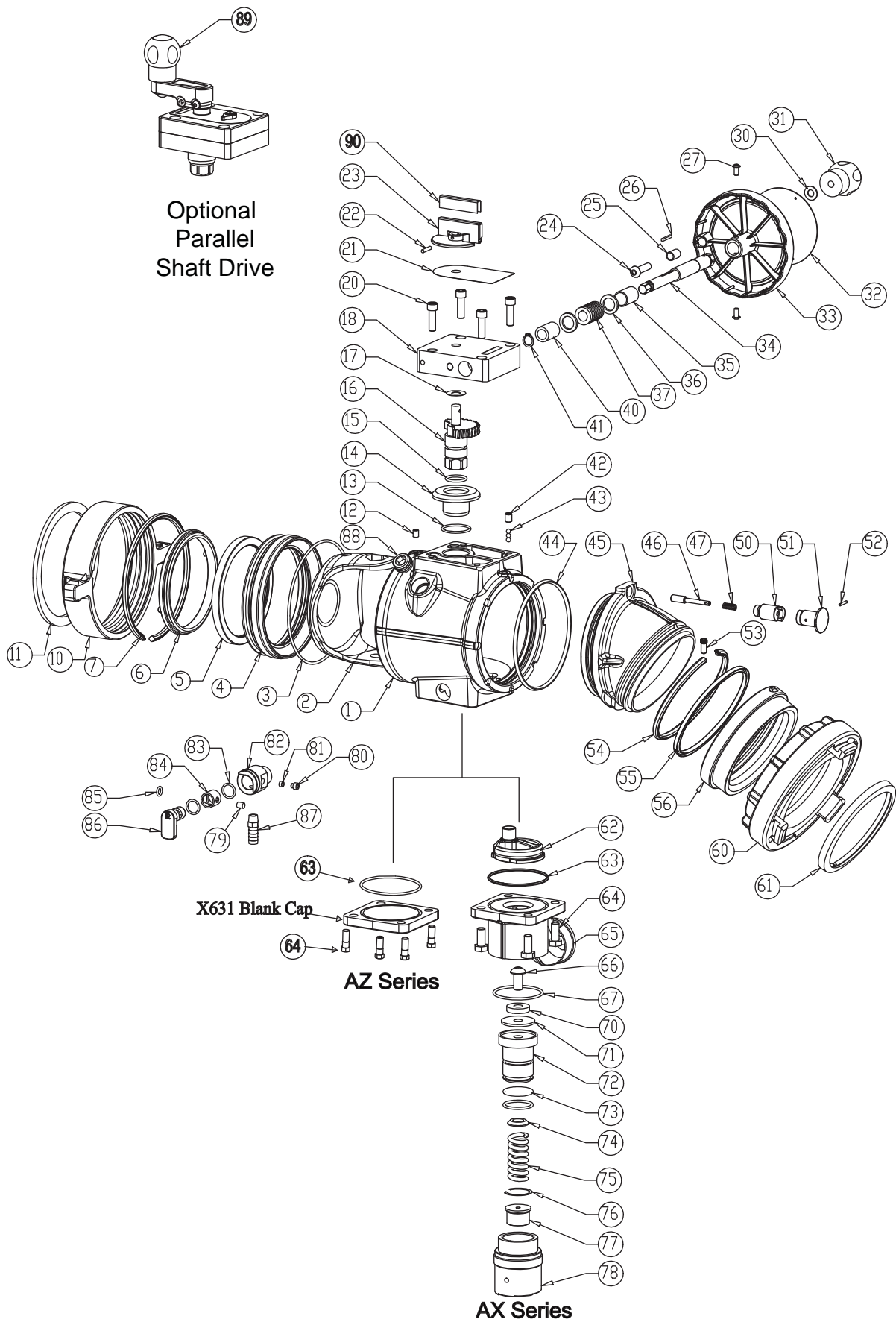

8.0 DRAWINGS AND PARTS LISTS

Jumbo Ball Intake Valve Parts List - AX & AZ Series

INDEX	DESCRIPTION	QTY	PART #
1	6" BALL INTAKE BODY	1	A1086
2	HALF BALL STAINLESS STEEL 8" DIA	1	A1088S
3	O-RING-262 7.0 ID 1/8 C/S	1	VO-262
4	6" BACK RING STAINLESS STEEL	1	A1084S
5	6" VALVE SEAT	1	A1082
6	6" SEAL RETAINER STAINLESS STEEL	1	A1080S
7	PLASTIC STRIP 7.00"	1	A1290
10	COUPLING SHORT HANDLED 6.0"NH FEMALE	1	A1266NX
	COUPLING SHORT HANDLED 6.0"NPSH FEMALE		A1266IX
11	GASKET - 6.0" HOSE COUPLING 70 +/-5SHORE	1	V3240
12	5/16-18 X 3/8 SOCKET SS CONE POINT	1	VT31-18CP375
13	O-RING-128 1-1/2 ID 3/32 C/S	1	VO-128
14	GEAR SPACER	1	A1511
15	O-RING-214 1 ID 1/8 C/S	1	VO-214
16	INTEGRAL WORM GEAR & TRUNNION	1	A1501
17	GEAR THRUST WASHER	1	A1502
18	GEAR BOX	1	A1506
20	3/8-16 X 1 1/4 SOCKET HEAD CAP SCREW	4	VT37-16SH1.2
21	LABEL BALL INTAKE GEARBOX	1	A1301
22	5/32 X 7/8 HDP SPIROL PIN #12437	1	V1900
23	POSITION INDICATOR	1	A1517
24	3/8-16 X 1-1/2 BUTTON HEAD CAP SCREW	1	VT37-16BH1.5
25	CRANK BUSHING	1	A1513
26	KEY; 1/8" X 1.00"	1	X225
27	1/4-20 X 1/2 BUTTON HEAD CAP SCREW	2	VT25-20BH500
30	WASHER .812"OD .406"ID .065"THICK	1	VW812X406-65
31	KNOB - SOFT TOUCH	1	A1512
32	HANDWHEEL LABEL; BIV	1	A1306
33	HANDWHEEL	1	X281
34	CRANK SHAFT	1	A1510
35	LARGE BUSHING	1	A1526
36	THIN WASHER	2	A1530
37	12 DP WORM	1	X220
40	SMALL BUSHING	1	A1525
41	RETAINING RING 15 MM EXTERNAL STAINLESS	1	VR4275
42	3/8-16 X 1/2 SOCKET SET SCREW CUP POINT	1	VT37-16SS500
43	1/4" BALL - 302 STAINLESS STEEL	72	V2125
44	CUP SEAL 6 ID 6 3/8 OD X 3/16 HGT	1	A1545
45	ELBOW (for 6" Female Couplings)	1	A1090
	ELBOW (for 6" Male Or 6" Storz)		A1091
	ELBOW (for 5" Female Couplings)		A1092
	ELBOW (for 5" Male Or 5" Storz)		A1054

INDEX	DESCRIPTION	QTY	PART #
46	DETENT PIN	1	A1560
47	PULL PIN SPRING	1	X345
50	DETENT PIN HOUSING	1	A1570
51	DETENT KNOB	1	A1575
52	1/8 X 3/4 HDP SPIROL PIN 12310	1	VP125X750H
53	LOCK-OUT SCREW	1	A1294
54	PLASTIC STRIP (for 6" Storz And 5" Threaded)	1	A1293
	PLASTIC STRIP (for 6" Female Coupling)		A1290
55	CUP SEAL LOADED (6" Storz And 5" Male Only)	1	A1594
56	INSERT 6.0"BSPM (6" Storz Only)	1	A1094
60	6" STORZ WITH LOCK	1	X696-LOCK
	COUPLING SHORT HANDLED 6.0"NH FEMALE		A1266NX
	COUPLING SHORT HANDLED 6.0"NH FEMALE		A1266IX
	SPOUT 6.0" NH MALE		A4640N
	COUPLING SHORT HANDLED 5"NH FEMALE		A1261NT
61	COUPLING SHORT HANDLED 5"NPSH FEMALE	1	A1261IT
	GASKET 6" STORZ PRESSURE		A4225
62	GASKET 6" STORZ SUCTION AND PRESSURE	1	A4226
	MIV TRUNNION STAINLESS STEEL		A1087
63	O-RING-236 3-1/4 ID 1/8 C/S	1	VO-236
64	7/16-14 X 1 HEX HEAD BOLT	4	VT43-14HX1.0
65	RELIEF VALVE HOUSING	1	A1150
66	1/2-13 X 1.0 BUTTON HEAD CAP SCREW	1	VT50-13BH1.0
67	O-RING-232 2-3/4 ID 1/8 C/S	1	VO-232
70	DEBRIS WASHER	1	A1169
71	VALVE SEAT PRV	1	A1168
72	PISTON	1	A1160
73	QUAD-RING-222 1-1/2 ID 1/8 C/S	2	VOQ-222
74	SPRING SEAT	1	A1166
75	RELIEF SPRING DACROMET COATED	1	A1170
76	WH-150-F-S02 SMALLEY RING 1.567/1.582"OD	1	V4210
77	ADJUSTING SCREW	1	A1167
78	SPRING HOUSING 200 MAX	1	A1164
79	5/16-18 X 3/8 SOCKET SET SCREW CUP POINT	1	VT31-18SS375
80	3/8-24 X 3/8 DOG POINT	1	H515
81	FOLLOWER	1	U251
82	DRAIN HOUSING	1	A1543
83	O-RING-115 11/16 ID 3/32 C/S	2	VO-115
84	DRAIN SLEEVE	1	A1541
85	O-RING-110 3/8 ID 3/32 C/S	1	VO-110
86	DRAIN LEVER	1	A1542
87	1/2" BARB X 1/4"NPTM NIPPLE	1	Xx329
88	3/4"NPTM HEX SOCKET PLUG	1	XG410
89	PARALLEL DRIVE GEARBOX	1	A1633
90	POSITION INDICATOR LABEL	1	A1524

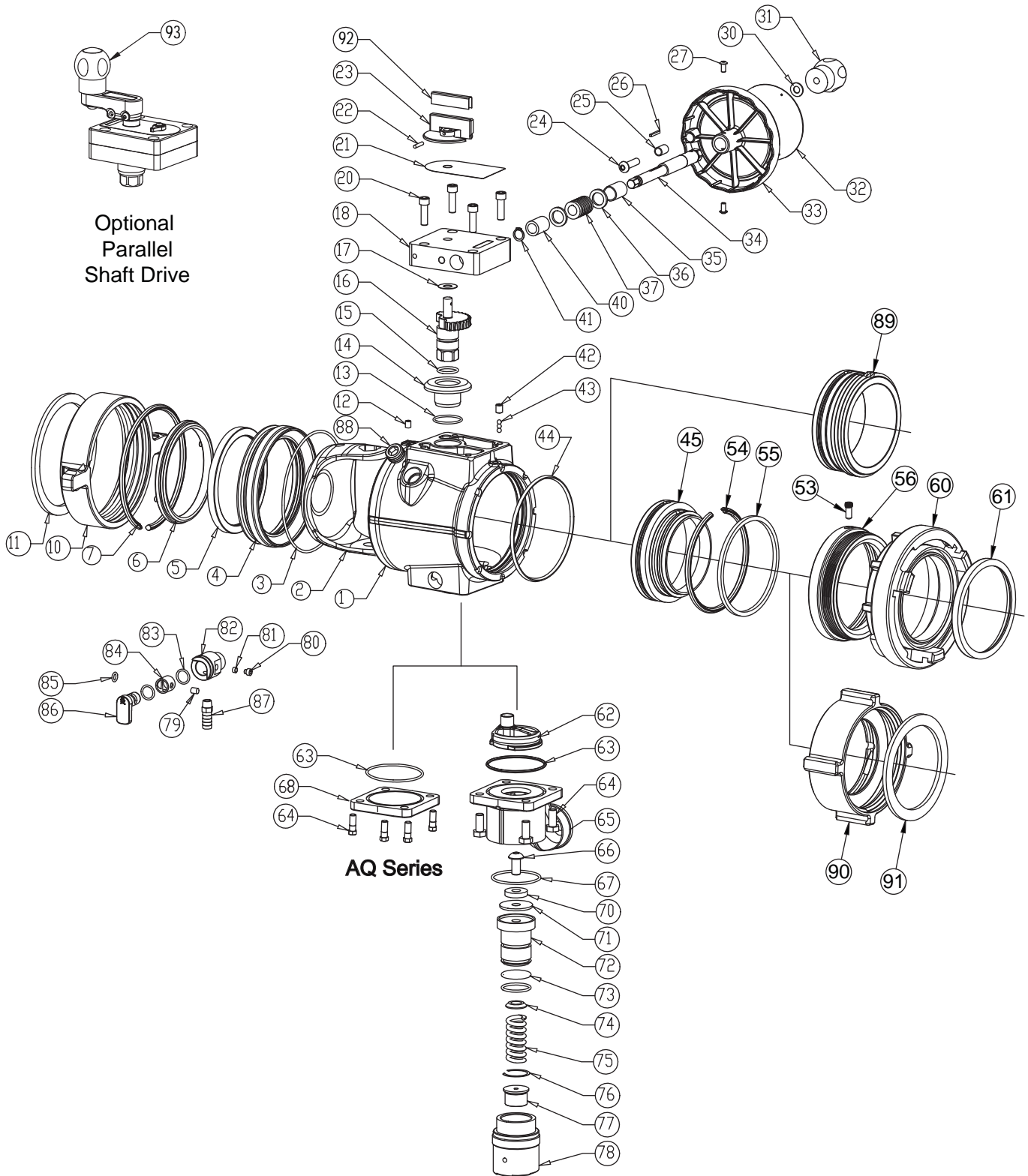

8.0 DRAWINGS AND PARTS LISTS

Jumbo Ball Intake Valve Parts List - AP & AQ Series

Index	Description	Qty	Part #
1	6" BALL INTAKE BODY	1	A1086
2	HALF BALL STAINLESS STEEL 8" DIA	1	A1088S
3	O-RING-262 7.0 ID 1/8 C/S	1	VO-262
4	6" BACK RING STAINLESS STEEL	1	A1084S
5	6" VALVE SEAT	1	A1082
6	6" SEAL RETAINER STAINLESS STEEL	1	A1080S
7	PLASTIC STRIP 7.00"	1	A1290
10	COUPLING SHORT HANDLED 6.0"NH FEMALE	1	A1266NX
	COUPLING SHORT HANDLED 6.0"NPSH FEMALE		A1266IX
11	GASKET - 6.0" HOSE COUPLING 70+/-5SHORE	1	V3240
12	5/16-18 X 3/8 SOCKET SS CONE POINT	1	VT31-18CP375
13	O-RING-128 1-1/2 ID 3/32 C/S	1	VO-128
14	GEAR SPACER	1	A1511
15	O-RING-214 1 ID 3/32 C/S	1	VO-214
16	INTERNAL WORM GEAR & TRUNNION	1	A1501
17	GEAR THRUST WASHER	1	A1502
18	GEAR BOX	1	A1056
20	3/8-16 X 1-1/4 SOCKET HEAD CAP SCREW	4	VT37-16SH1.2
21	LABEL BALL INTAKE GEARBOX	1	A1301
22	5/32 X 7/8 HDP SPIROL PIN #12437	1	V1900
23	POSITION INDICATOR	1	A1517
24	3/8-16 X 1-1/2 BUTTON HEAD CAP SCREW	1	VT37-16BH1.5
25	CRANK BUSHING	1	A1513
26	KEY; 1/8" X 1.00"	1	X225
27	1/4-20 X 1/2 BUTTON HEAD CAP SCREW	2	VT25-20BH500
30	WASHER .812"OD .406"ID .065"THICK	1	VW812X406-65
31	KNOB - SOFT TOUCH	1	A1512
32	HANDWHEEL LABEL; BIV	1	A1306
33	HANDWHEEL	1	X281
34	CRANK SHAFT	1	A1510
35	LARGE BUSHING	1	A1526
36	THIN WASHER	2	A1530
37	12 DP WORM	1	X220
40	SMALL BUSHING	1	A1525
41	RETAINING RING 15 MM EXTERNAL STAINLESS	1	VR4275
42	3/8-16 X 1/2 SOCKET SET SCREW CUP POINT	1	VT37-16SS500
43	1/4" BALL - 302 STAINLESS STEEL	72	V2125
44	CUP SEAL 6 ID 6-3/8 OD X 3/16 HGT	1	A1545
45	MATE HSBGM60 X PSM6.0	1	A1093
	MATE HSBGM60 X PSM5.25		A1055
53	LOCK-OUT SCREW	1	A1294
54	PLASTIC STRIP (for 6" Storz and 5" Threaded)	1	A1293
	PLASTIC STRIP (for 6" Female Coupling)	1	A1290
55	CUP SEAL LOADED (6" Storz and 5" Male Only)	1	A1594
56	INSERT 6.0"BSPM (6" Storz Only)	1	A1094

60	STORZ W/LOCK 4" COUPLING SUBASSEMBLY	1	A4124
	STORZ W/LOCK 5" COUPLING SUBASSEMBLY	1	A4125
	STORZ W/LOCK 6" COUPLING SUBASSEMBLY	1	A4326
	PLASTIC STRIP 6.00"	1	A1293
	LABEL; PORT COVER	1	A1298
	CUP SEAL LOADED	1	A1594
61	GASKET 6" STORZ PRESSURE	1	A4225
	GASKET 6" STORZ SUCTION AND PRESSURE		A4226
62	MIV TRUNNION STAINLESS STEEL	1	A1087
63	O-RING-236 3-1/4 ID 1/8 C/S	1	VO-236
64	7/16-14 X 1 HEX HEAD BOLT	4	VT43-14HX1.0
65	RELIEF VALVE HOUSING	1	A1150
66	1/2-13 X 1.0 BUTTON HEAD CAP SCREW	1	VT50-13BH1.0
67	O-RING-232 2-3/4 ID 1/8 C/S	1	VO-232
68	LDH BLANK CAP	1	X631
70	DEBRIS WASHER	1	A1169
71	VALVE SEAT PRV	1	A1168
72	PISTON	1	A1160
73	QUAD-RING-222 1-1/2 ID 1/8 C/S	2	VOQ-222
74	SPRING SEAT	1	A1166
75	RELIEF SPRING DACROMET COATED	1	A1170
76	WH-150-F-S02 SMALLEY RING 1.567/1.582"OD	1	V4210
77	ADJUSTING SCREW	1	A1167
78	SPRING HOUSING 200 MAX	1	A1164
79	5/16-18 X 3/8 SOCKET SET SCREW CUP POINT	1	VT31-18SS375
80	3/8-24 X 3/8 DOG POINT	1	H515
81	FOLLOWER	1	U251
82	DRAIN HOUSING	1	A1543
83	O-RING-115 11/16 ID 3/32 C/S	2	VO-115
84	DRAIN SLEEVE	1	A1541
85	O-RING-110 3/8 ID 3/32 C/S	1	VO-110
86	DRAIN LEVER	1	A1542
87	1/2" BARB X 1/4"NPTM NIPPLE	1	XX329
88	3/4"NPTM HEX SOCKET PLUG	1	XG410
89	SPOUT 5.0"NHM X HSBGM60	1	A4631N
	SPOUT 6.0"NHM X HSBGM60		A4641N
90	COUPLING RL 4.0"NHF X PSF5.25	1	A4662N
	NFS RING 4.0	1	A4561
	COUPLING RL 4.5"NHF X PSF5.25	1	A4667N
	NFS RING 4.5	1	A4566
	COUPLING RL 5"NHF X PSF5.25	1	A4670N
	SPOUT 4.0"NHM X PSF5.25	1	A4620N
91	SPOUT 4.5"NHM X PSF5.25	1	A4625N
	GASKET 4.0" HOSE COUPLING	1	V3198
	GASKET 4.5" HOSE COUPLING		V3210
GASKET 5.0" HOSE COUPLING	V3220		
92	POSITION INDICATOR LABEL	1	A1524
93	PARALLEL DRIVE GEARBOX SUBASSEMBLY	1	A1633

8.0 DRAWINGS AND PARTS LISTS

Motor Assembly BIV RC & Jumbo BIV RC

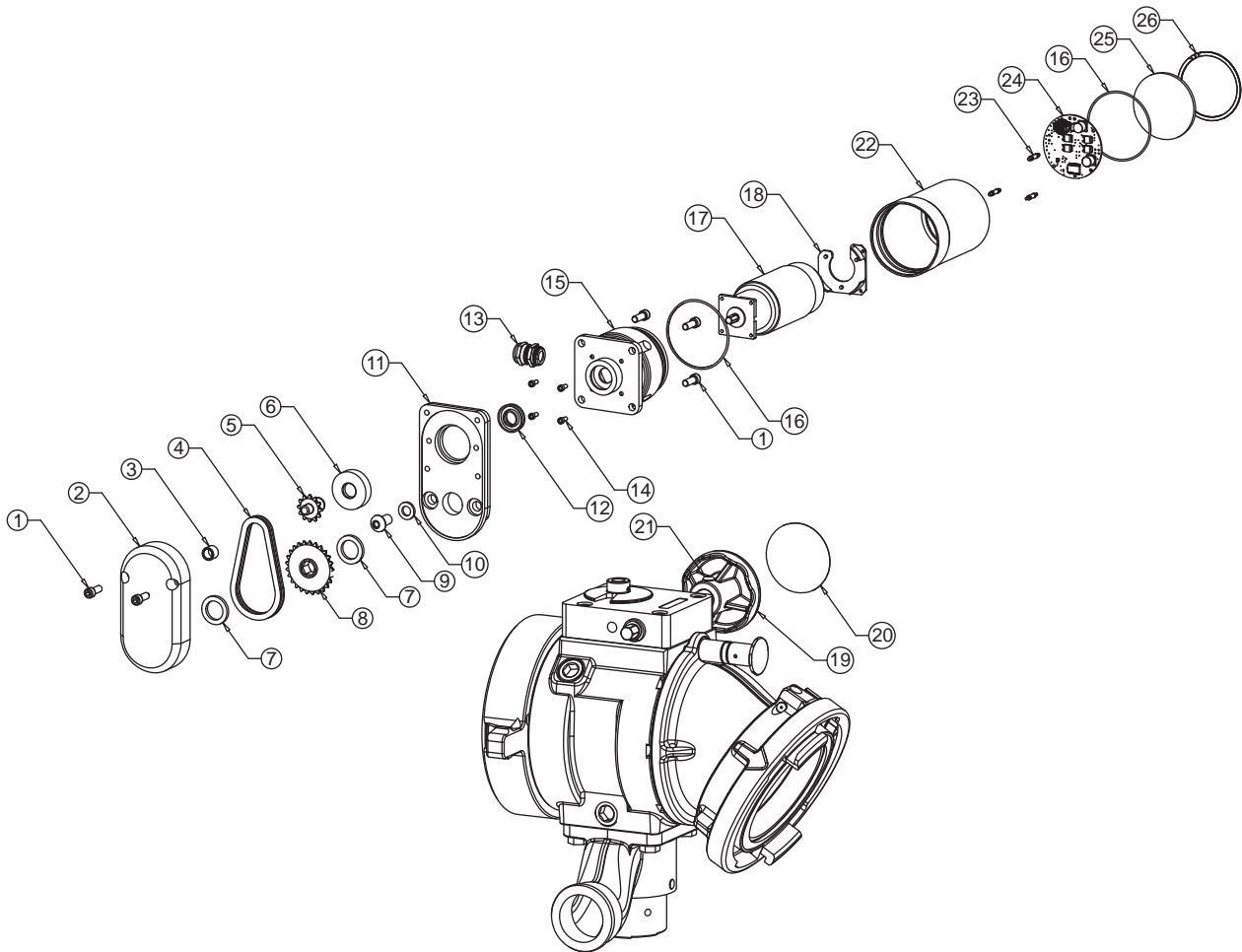

INDEX	DESCRIPTION	QTY	PART #
1	1/4-28 X 5/8 SOCKET HEAD CAP SCREW	6	VT25-28SH625
2	REDUCER COVER	1	A1097
3	BUSHING NYLON	1	X252
4	38LINK ROLLER CHAIN	1	AX1685
5	DRIVE SPROCKET 12 TEETH	1	X253
6	BUSHING MOTOR	1	X256
7	THIN WASHER	2	A1530
8	BIV SPROCKET 25 TEETH	1	A1098
9	3/8-16 X 3/4 BUTTON HEAD CAP SCREW	1	VT37-16BH750
10	LOCK WASHER 3/8"	1	VW375SSLOCK
11	REDUCER HOUSING	1	A1096
12	CUP SEAL 1.0625 X .5625 X 1/4	1	Y4620
13	STRAIN RELIEF PG11 .39 HOLE	1	Y5205
14	6-32 X 5/16 LONG SHCS WITH HEAD SEAL	4	VT06S32SH312
15	MOTOR SOCKET	1	Y4615
16	O-RING-038 2-5/8 ID 1/16 C/S	2	VO-038
17	GEAR MOTOR W/CRIMPED TERMINALS	1	Y4600
18	MOTOR BOARD SUPPORT	1	Y4643
19	KNOB	1	Z245
20	OVERRIDE KNOB LABEL	1	Y4176
21	1/4-20 X 1/2 BUTTON HEAD CAP SCREW	2	VT25-20BH500
22	MOTOR ENCLOSURE TUBE	1	Y4641
23	CIRCUIT BOARD STANDOFF	3	Y5538
24	VALVE MOTOR BOARD	1	A5825
25	MOTOR ENCLOSURE CAP	1	Y4642
26	SMALLEY RING	1	V4295

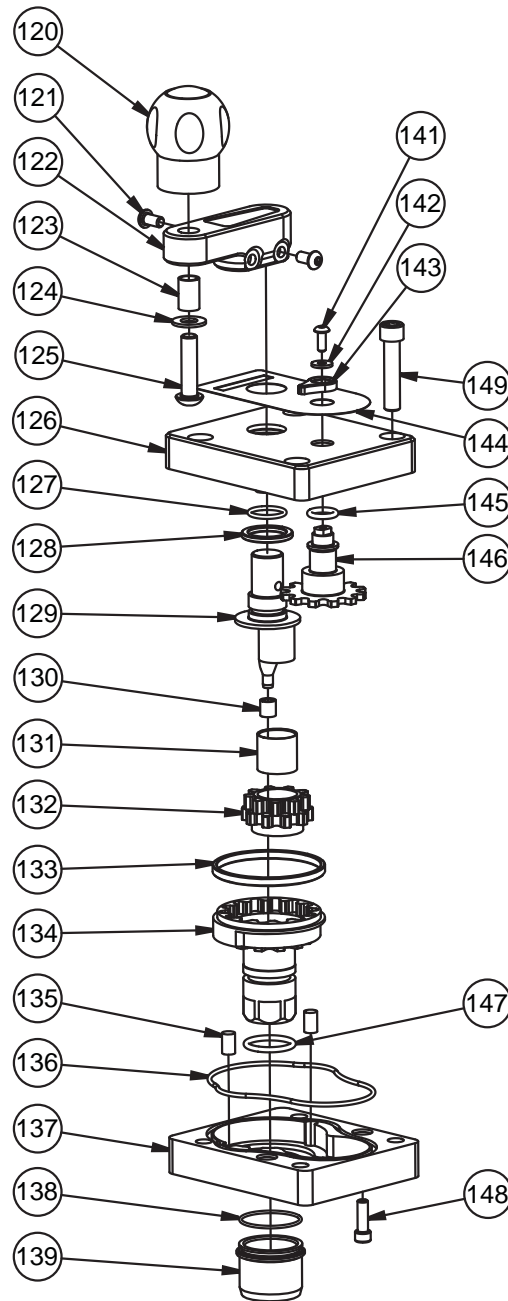

ITEM	DESCRIPTION	QTY	PART #
120	KNOB	1	A1512
121	1/4-20 X 1/2 BUTTON HEAD SCREW	2	VT25-20BH500
122	CRANK	1	A1559
123	CRANK BUSHING	1	A1547
124	WASHER	1	VW812X406-65
125	3/8-16 X 1-1/2 BUTTON HEAD SCREW	1	VT37-16BH1.5
126	GEAR BOX	1	A1550
127	O-RING-116	1	VO-116
128	SPACER	1	A1556
129	DRIVE SHAFT	1	A1555
130	NYLON BUSHING	1	AY307
131	GEAR BUSHING	1	A1548
132	DOUBLE GEAR	1	A1554
133	BUSHING	1	A1549
134	INNER TRUNNION	1	A1553

ITEM	DESCRIPTION	QTY	PART #
135	DOWEL PIN	2	VP312X.50
136	O-RING-154	1	VO-154
137	SUBPLATE	1	A1551
138	O-RING-028	1	VO-028
139	INNER BUSHING	1	A1552
141	10-24 X 3/8 BUTTON HEAD SCREW	1	VT10-24BH500
142	WASHER	1	VW500X203-60
143	POSITION INDICATOR	1	A1558
144	BIV NAME LABEL	1	A1550L
145	O-RING-206	1	VO-206
146	INDICATOR GEAR	1	A1557
147	O-RING-214	1	VO-214
148	1/4-20 X 3/4 SOCKET HEAD SCREW	1	VT25-20SH750
149	3/8-16 X 1 1/2 SOCKET HEAD SCREW	4	VT37-16SH1.7

9.0 TROUBLE SHOOTING

SYMPTOM	POSSIBLE CAUSE	REMEDY
Leaks	Debris or damage in seal area	Clean out debris or replace damaged parts
Binding, Erratic operation	Low Voltage (see below)	See Below
Power LED on but no operation	Low voltage due to: -wire gage too small -wire length too long -poor connection -inadequate apparatus electrical system	Check connections and wiring per section 4.3
LED D6 on motor board blinks rapidly when button is pressed	Loose encoder connection	Replace Motor Sub Assembly
	Bad motor encoder	Replace Motor Sub Assembly
No Power LED	Polarity reversed or poor connection	Check wiring and correct polarity
OPEN & CLOSE LED blink every 4 seconds	No communication with Valve Motor	Check Blue & White communication wiring

10.0 MAINTENANCE

This valve should be disconnected, cleaned and visually inspected inside and out at least twice annually, or as water quality and use may require. Moving parts such as hand wheels, valve ball and couplings should be checked for smooth and free operation. Seals shall be greased as needed with a Silicone based grease such as Dow Corning 112. Any scrapes that expose bare aluminum should be cleaned and touched up with enamel paint such as Rust-Oleum. Replace any missing or damaged parts before returning valve to service.



Dissimilar metals coupled together can cause galvanic corrosion that can result in the inability to unscrew the threads of complete loss of thread engagement over time. Per NFPA 1962 (1998 edition), if dissimilar metals are left coupled together an anti-corrosive lubricant should be applied to the threads. Also the coupling should be disconnected and inspected at least quarterly.



Any alterations to the Ball Intake Valve and its markings could diminish safety and constitutes a misuse of this product.

11.0 BALL INTAKE VALVE PRESSURE LOSS

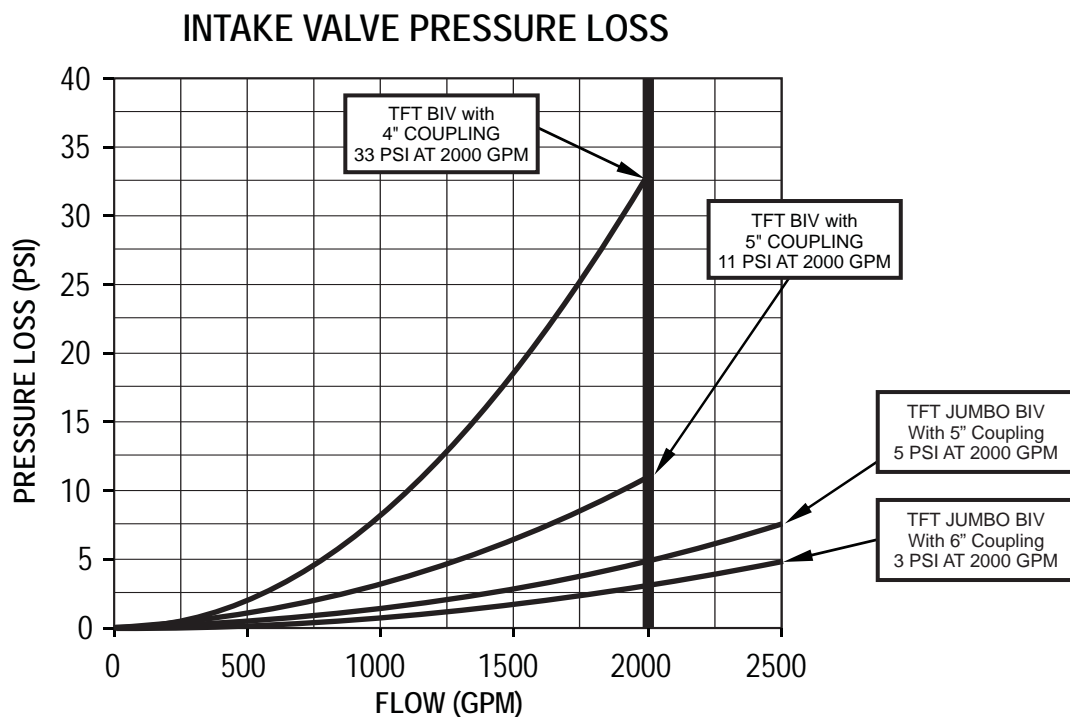

12.0 TEMPLATES

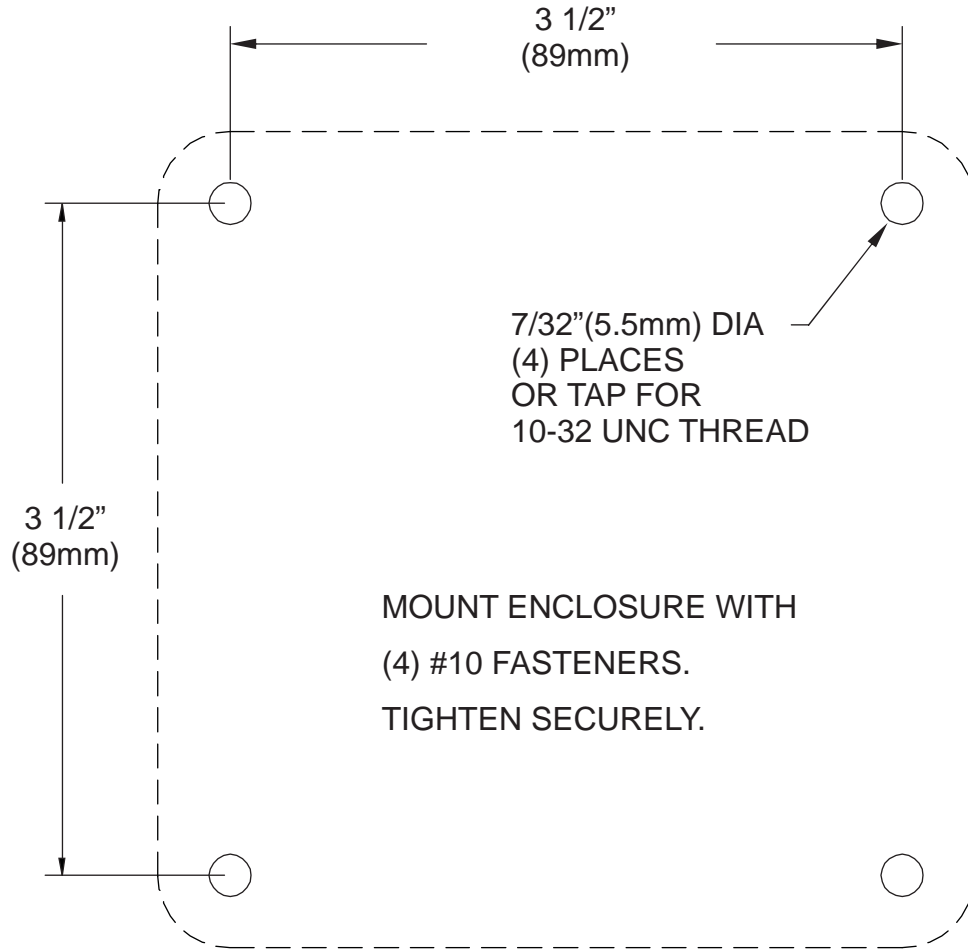

HOLE LOCATIONS FOR BIV RC POSITION DISPLAY
TEMPLATE 4.2A

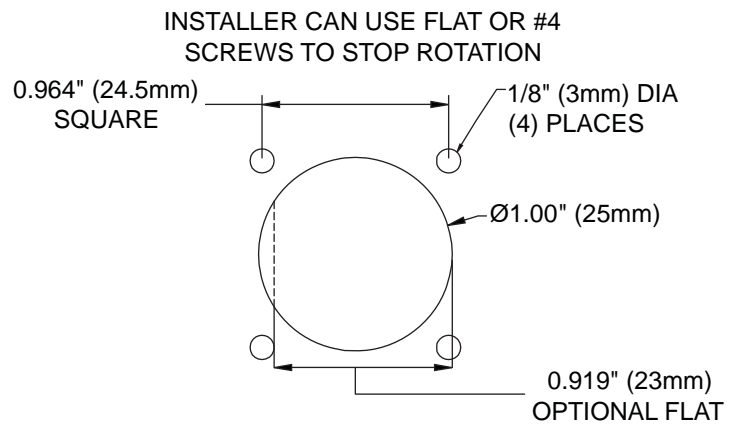

HOLE LOCATIONS FOR QUICK CONNECT PLUG
TEMPLATE 4.2B

13.0 WARRANTY

Task Force Tips, Inc., 3701 Industrial Way, Valparaiso, Indiana 46383-9327 USA (“TFT”) warrants to the original purchaser of its Ball Intake Valve and Ball Intake Valve RC (“equipment”), and to anyone to whom it is transferred, that the equipment shall be free from defects in material and workmanship during the five (5) year period from the date of purchase.

TFT’s obligation under this warranty is specifically limited to replacing or repairing the equipment (or its parts) which are shown by TFT’s examination to be in a defective condition attributable to TFT. To qualify for this limited warranty, the claimant must return the equipment to TFT, at 3701 Industrial Way, Valparaiso, Indiana 46383-9327 USA, within a reasonable time after discovery of the defect. TFT will examine the equipment. If TFT determines that there is a defect attributable to it, TFT will correct the problem within a reasonable time. If the equipment is covered by this limited warranty, TFT will assume the expenses of repair.

If any defect attributable to TFT under this limited warranty cannot be reasonably cured by repair or replacement, TFT may elect to refund the purchase price of the equipment, less reasonable depreciation, in complete discharge of its obligations under this limited warranty. If TFT makes this election, claimant shall return the equipment to TFT free and clear of any liens and encumbrances.

This is a limited warranty. The original purchaser of the equipment, any person to whom it is transferred, and any person who is an intended or unintended beneficiary of the equipment, shall not be entitled to recover from TFT any consequential or incidental damages for injury to person and/or property resulting from any defective equipment manufactured or assembled by TFT. It is agreed and understood that the price stated for the equipment is in part consideration for limiting TFT’s liability. Some states do not allow the exclusion or limitation of incidental or consequential damages, so the above may not apply to you.

TFT shall have no obligation under this limited warranty if the equipment is, or has been, misused or neglected (including failure to provide reasonable maintenance) or if there have been accidents to the equipment or if it has been repaired or altered by someone else.

THIS IS A LIMITED EXPRESS WARRANTY ONLY. TFT EXPRESSLY DISCLAIMS WITH RESPECT TO THE EQUIPMENT ALL IMPLIED WARRANTIES OF MERCHANTABILITY AND ALL IMPLIED WARRANTIES OF FITNESS FOR A PARTICULAR PURPOSE. THERE IS NO WARRANTY OF ANY NATURE MADE BY TFT BEYOND THAT STATED IN THIS DOCUMENT.

This limited warranty gives you specific legal rights, and you may also have other rights which vary from state to state.

14.0 ANSWERS TO YOUR QUESTIONS

We appreciate the opportunity of serving you and making your job easier. If you have any problems or questions, our toll-free “Hydraulics Hotline”, 800-348-2686, is normally available to you 24 hours a day, 7 days a week.