

5

This Spray Nozzle has met Grade A Class 1, Type A, Hull Mounted, Medium Weight shock requirements by Shock Testing.
 Shock Test Report: Aero-Nav Laboratories, Inc., 0-5403-2A Rev A, Dated June 15, 2010 and Post Shock Test Report TST0156, Dated July 8, 2010.
 Shock Test Report Approval: Supervisor of Shipbuilding, Bath, Maine Letter 9072, Ser 252/1277 Dated September 22, 2010.
 Any change to this drawing or lower tier drawing requires review and approval to maintain shock certification.

TASK FORCE TIPS, INC.
 2800 E. EVANS AVE.
 VALPARAISO, IN 46383
 219-462-6161



| REV | DATE | INITIALS |
|-----|----------|----------|
| 2 | 3/30/05 | CPD |
| 3 | 2/21/07 | CPD |
| 4 | 10/14/09 | CPD |
| 5 | 10/12/10 | CPD |

SCALE: 2/3x

PRINT DRAWN

9/2/99 BMH

PRINT APPROVED

10/12/10 M.B.M.

DESIGN ENGINEER

Robert W. Steingass

DIMENSIONS IN 'INCHES' UNLESS SPECIFIED OTHERWISE

FILE: B\FIN & SUB\B-BGH

F04-0052-01 REV. 00

PART NUMBER: B-BGH

SHEET
1 OF 3

DESCRIPTION: ULTIMATIC W/GRIP 1.0" FEMALE

EXTRA DESC: 10-125 GPM AT 100 PSI

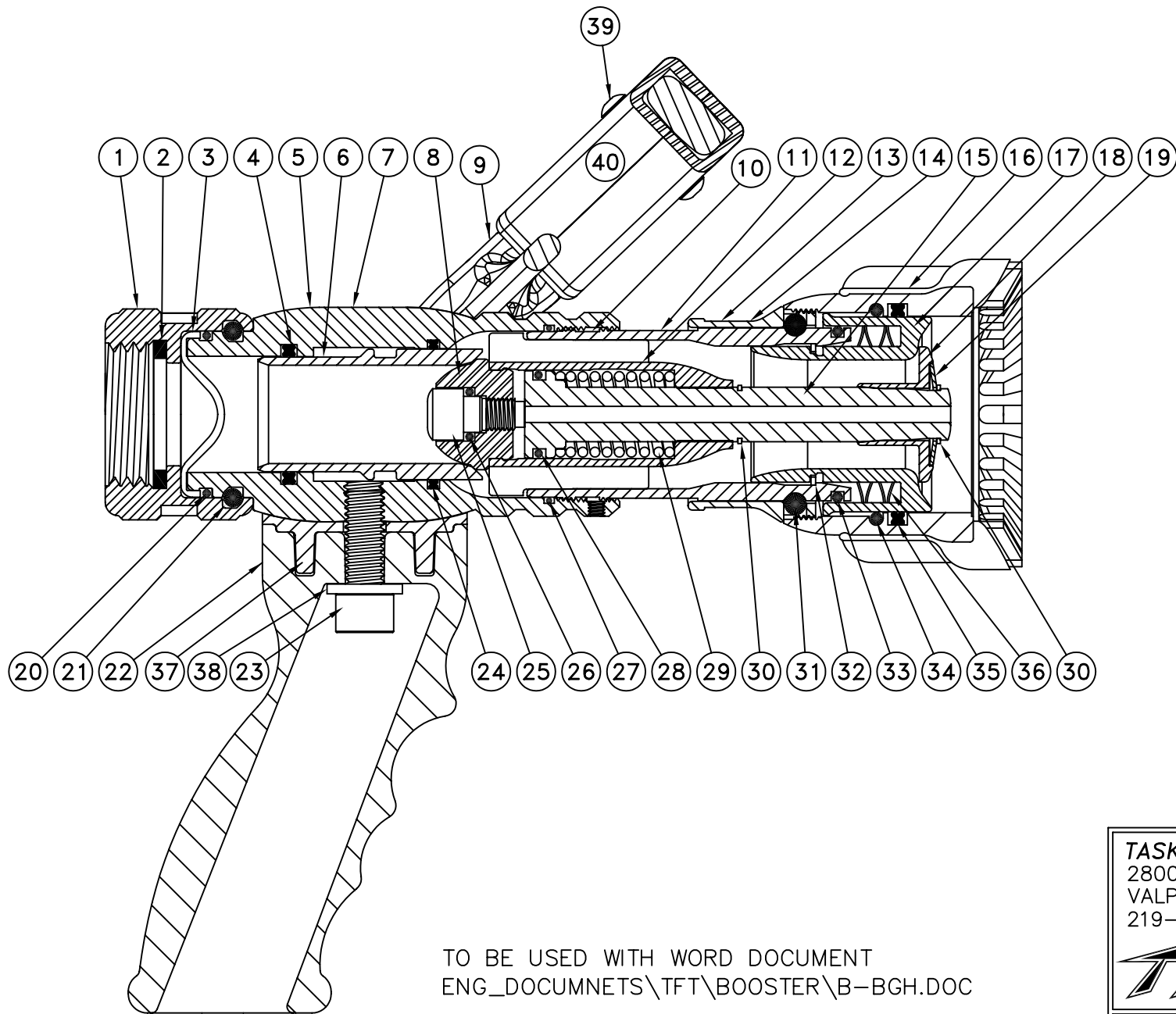

TO BE USED WITH WORD DOCUMENT
 ENG_DOCUMNETS\TFT\BOOSTER\B-BGH.DOC

TASK FORCE TIPS, INC.
 2800 E. EVANS AVE.
 VALPARAISO, IN 46383
 219-462-6161



| REV | DATE | INITIALS |
|-----|----------|----------|
| 2 | 3/30/05 | CPD |
| 3 | 2/21/07 | CPD |
| 4 | 10/14/09 | CPD |
| 5 | 10/12/10 | CPD |

SCALE: 2/3x
 PRINT DRAWN 3/29/95 MBJ
 PRINT APPROVED 10/12/10 M.B.M. Robert W. Steingass
 DESIGN ENGINEER
 DIMENSIONS IN 'INCHES' UNLESS SPECIFIED OTHERWISE
 FILE: B\FIN & SUB\B-BGH

PART NUMBER: B-BGH

SHEET
 2 OF 3

DESCRIPTION: ULTIMATIC W/GRIP 1.0" FEMALE - CUTAWAY

EXTRA DESC: 10-125 GPM AT 100 PSI

**ULTIMATIC
MODEL B-BGH**

| | Description | Qty | Order # |
|----|---------------------------|------------|----------------|
| 1 | 1" NH COUPLING | 1 | B680N |
| 2 | COUPLING GASKET 1.0" | 1 | V3040 |
| 3 | 1.0 GASKET GRABBER | 1 | B730 |
| 4 | QUAD-RING-216 | 1 | VOQ-4216 |
| 5 | VALVE BODY | 1 | B600 |
| | VALVE DISKS | 2 | B640 |
| | WS-93-SO2 SMALLEY RING | 2 | V4260 |
| | DRAG NUBS | 4 | B650 |
| | CAM PIN | 1 | B630 |
| | SAFETY PIN | 1 | B635 |
| | SPRINGS | 2 | VM4195 |
| | 3/16" TORLON BALL | 2 | V2120-TORLON |
| | 5/16-18 X 1/2 BUTTON HEAD | 2 | VT31E18BH500 |
| 6 | SLIDER | 1 | B660 |
| 7 | VALVE LABEL | 1 | B750 |
| 8 | VALVE PLUG | 1 | B590 |
| 9 | VALVE HANDLE | 1 | B622 |
| 10 | BARREL | 1 | B540 |
| 11 | BARREL LABEL | 1 | B740 |
| 12 | SPRING CAN | 1 | B580 |
| 13 | NAME LABEL | 1 | B745 |
| 14 | SHAPER GUIDE | 1 | B510 |
| 15 | SHAFT | 1 | B570 |
| 16 | SHAPER WITH BUMPER | 1 | B500 |
| 17 | BARREL CONE | 1 | B525 |
| 18 | BAFFLE | 1 | B560 |
| 19 | SPRING WASHER - 100 PSI | 1 | B565 |
| 20 | O-RING-127 | 1 | VO-127 |
| 21 | 3/16" SS BALL | 28 | V2120 |
| 22 | PISTOL GRIP | 1 | HM692-BLK |
| 23 | 3/8-16 X 1.00 SHCS | 1 | VT37-16SH1.0 |
| 24 | QUAD-RING-124 | 1 | VOQ-4124 |
| 25 | I/O SCREW | 1 | B595 |
| 26 | O-RING-109 | 1 | VO-109 |
| 27 | O-RING-030 | 1 | VO-030 |
| 28 | O-RING-115 | 1 | VO-115 |
| 29 | CONTROL SPRING 100 PSI | 1 | B760 |
| 30 | WSM-50-SO2 SMALLEY RING | 2 | V4280 |
| 31 | 7/32" BALL - TORLON | 4 | V2130-TORLON |
| 32 | WS-128-F-SO2 SMALLEY RING | 1 | V4270 |
| 33 | O-RING-128 | 1 | VO-128 |
| 34 | 1/8" BALL - #101 NYLON | 46 | V2135 |
| 35 | QUAD-RING-225 | 1 | VOQ-4225 |

| | | | |
|----|-------------------------|---|--------------|
| 36 | FLUSH WAVE SPRING | 1 | B785 |
| 37 | GRIP SPACER - ULTIMATIC | 1 | HM693-U |
| 38 | 3/8" FLAT WASHER | 1 | VM4901 |
| 39 | 8-32 BH SCREW | 4 | VT08E32BH375 |
| 40 | HANDLE COVER | 2 | HM625-BLK |

TO BE USED WITH AUTOCAD FILE: B\FIN & SUB\B-BGH

FILENAME: WORD\TFT\BOOSTER\B-BGH

WRITTEN: 3/29/95 BY: MBJ

REV. #5 DATE: 10/12/10 BY: CPD

APPROVED: 10/12/10 BY: MDM